



# County of Dare

P.O. Box 1000 | Manteo, NC 27954

## DARE COUNTY BOARD OF COMMISSIONERS

Dare County Administration Building  
954 Marshall C. Collins Dr., Manteo, NC

Tuesday, May 07, 2019

**“HOW WILL THESE DECISIONS IMPACT OUR CHILDREN AND FAMILIES?”**

### AGENDA

**9:00 AM CONVENE, PRAYER, PLEDGE OF ALLEGIANCE**

**ITEM 1** Opening Remarks - Chairman's Update

**ITEM 2** Presentation of County Service Pins

**ITEM 3** Employee of the Month

**ITEM 4** Public Comments

**ITEM 5** Award from American Shore and Beach Preservation Association

**ITEM 6** Proclamation for 2019 EMS Week

**ITEM 7** Report from the A.B.C. Board

**ITEM 8** Closed Session

**ITEM 9** Contract for Dare County Dredge Vessel

**ITEM 10** Consent Agenda

1. Approval of Minutes, 04.15.19 & 04.17.19 Budget Workshop
2. Water Line Relocation Agreement - NCDOT Hwy 12 Rodanthe Long-Term Improvements
3. Private Land Burning Agreement between Dare County and US Fish and Wildlife Service
4. Town Of Manteo Request - Delegate Approval of Pyrotechnics Permits
5. NCDOT Utility Relocation Agreement - Skyco Road & Toler Road
6. Social Services Division - 14-month Contract with Information, Inc.
7. Public Health Division - Contract with Outer Banks Womens Care
8. Register of Deeds - Software License and Support Agreement
9. Assistant Medical Director Agreement
10. Audit Contract for Fiscal Year 2019
11. Tax Collector's Report

Agenda – Continued on other side

- ITEM 11** Board Appointments
1. Dare County Board of Adjustment
  2. Senior Tar Heel Legislative Delegates
  3. Veterans Advisory Council
  4. Upcoming Board Appointments

**ITEM 12** Commissioners' Business & Manager's/Attorney's Business

ADJOURN UNTIL 5:00 P.M. ON MAY 20, 2019



*Opening Remarks - Chairman's Update*

**Description**

Dare County Chairman Robert Woodard will make opening remarks.

**Board Action Requested**

Informational Presentation

**Item Presenter**

Chairman Robert Woodard



*Presentation of County Service Pins - May 2019*

**Description**

The following employees are scheduled to receive service pins this month:

1. Brooke Atwell, Emergency Med Tech Paramedic - 10 Year Pin
2. Linda Webb, Detention Officer - 20 Year Pin

**Board Action Requested**

None

**Item Presenter**

Robert Outten, County Manager



**Presentation of County Service Pins**

1. Brooke Atwell, Emergency Med Tech Paramedic – 10 Year Pin  
Presented by Terence Sheehy
2. Linda Webb, Detention Officer – 20 Year Pin  
Presented by Allen Moran



Employee of the Month

**Description**

The Employee of the Month Certificate will be presented.

**Board Action Requested**

None

**Item Presenter**

To Be Determined.



*Public Comments*

**Description**

The Board of Commissioners encourages citizen participation and provides time on the agenda at every regularly scheduled meeting for Public Comments. This is an opportunity opportunity for anyone to speak directly to the entire Board of Commissioners for up to five minutes on any topic or item of concern.

Comments can be made at the Commissioners Meeting Room in Manteo or through an interactive video link at the Fessenden Center Annex in Buxton.

Commissioners Meeting Room - Administration Building, 954 Marshall Collins Drive, Manteo  
Video Link - Fessenden Center Annex, 47017 Buxton Back Road, Buxton

**Board Action Requested**

Hear Public Comments

**Item Presenter**

Robert Outten, County Manager



*Award from American Shore and Beach Preservation Association*

**Description**

The American Shore and Beach Preservation Association (ASBPA) has recognized Dare County beaches by naming them as a 2018 Best Restored Beach. The ASBPA award, which highlights the value of restored beaches, salutes the effort taken by the County and the municipalities of Duck, Southern Shores, Kitty Hawk and Kill Devil Hills.

**Board Action Requested**

None - Award will be presented

**Item Presenter**

Robert Outten, County Manager



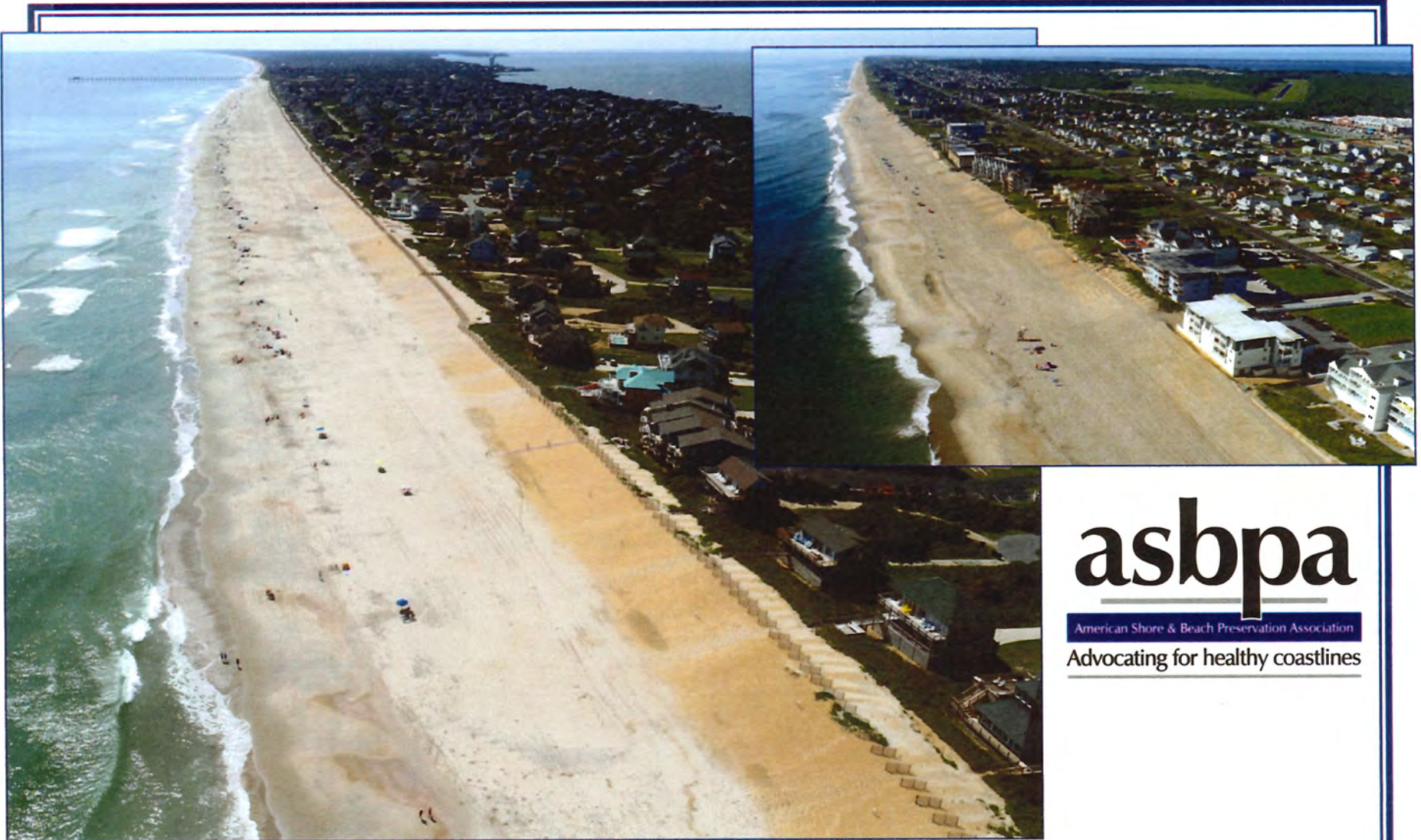

**asbpa**

American Shore & Beach Preservation Association

Advocating for healthy coastlines

**Dare County**

*North Carolina*

***A 2018 Best Restored Beach***





## County of Dare

### Department of Public Relations

P.O. Box 1000 | Manteo, North Carolina 27954 | 252.475.5000

#### For Immediate Release:

May 21, 2018

#### Contact:

Dorothy Hester, PIO  
dorothy@darenc.com  
252.475.5903

## Dare County Beaches Receive ASBPA Best Restored Beaches Award

Dare County beaches in Duck, Southern Shores, Kitty Hawk and Kill Devil Hills have been named as Best Restored Beaches for 2018 by the American Shore and Beach Preservation Association (ASBPA). The award highlights the value of restored beaches and the crucial role they play in providing wide and beautiful beaches that attract people from around the world. Visitors to Dare County spend more than \$1.1 billion annually, supporting over 13,100 local jobs and generating more than \$102 million in state and local tax revenue.

According to Bob Woodard, Chairman of the Dare County Board of Commissioners, "Dare County is committed to preserving our beaches. They are the engine that drives our tourism economy and they require ongoing attention. That is why Dare County and its municipalities have stepped up to the plate and committed local resources to fund beach nourishment projects due to the lack of federal funding."

Dare County and its municipalities have invested resources in beach nourishment, a process by which sand that is lost through erosion is replaced to create a wider beach that reduces storm damage by dissipating wave energy to provide protection from storm surges and unusually high tides.

Dare County's beach nourishment fund consists of revenue that is generated by a portion of the occupancy tax that is collected on short term rental properties such as hotels and cottages. These local dollars have helped fund beach nourishment projects throughout the county since 2011.

It was one year ago this week that work began on the northern beaches project and over a five month period, almost four million cubic yards of sand was placed along 8.3 miles of beach. This project was done as a collaborative effort including Dare County and the towns of Duck, Southern Shores, Kitty Hawk and Kill Devil Hills. By working together, each of the towns was able to achieve their design goals while benefiting from a significant cost and time savings in both the permitting and construction phases of the project.

According to Program Manager Ken Willson of APTIM, "Dare County's collaborative effort is a model to be considered nationwide by communities trying to increase coastal resilience. This approach enabled considerable cost and time savings. For example, we've estimated that by constructing the projects cooperatively, the locals achieved a cost savings of around \$5.5 million on mobilization alone."

Mayors from all four of the project municipalities joined Chairman Woodard in making the announcement about the ASPBA award at Monday evening's meeting. Chairman Woodard commented, "I think we all agree that in order to remain as sustainable and resilient coastal communities, we must continue to prioritize protection of our beaches as a vital component of our tourism infrastructure."

*Land of Beginnings*



*Proclamation for 2019 EMS Week*

**Description**

Proclamation recognizing May 19-25, 2019 as EMS Week.

**Board Action Requested**

Approve/issue proclamation

**Item Presenter**

Chief Jennie Collins

## 2019 EMS WEEK PROCLAMATION

**WHEREAS**, emergency medical services is a vital public service; and

**WHEREAS**, the members of emergency medical services teams are ready to provide lifesaving care to those in need 24 hours a day, seven days a week; and

**WHEREAS**, access to quality emergency care dramatically improves the survival and recovery rate of those who experience sudden illness or injury; and

**WHEREAS**, emergency medical services has grown to fill a gap by providing important, out of hospital care, including preventative medicine, follow-up care, and access to telemedicine; and

**WHEREAS**, the emergency medical services system consists of first responders, emergency medical technicians, paramedics, emergency medical dispatchers, firefighters, police officers, educators, administrators, pre-hospital nurses, emergency nurses, emergency physicians, trained members of the public, and other out of hospital medical care providers; and

**WHEREAS**, the members of emergency medical services teams engage in thousands of hours of specialized training and continuing education to enhance their lifesaving skills; and

**WHEREAS**, it is appropriate to recognize the value and the accomplishments of emergency medical services providers by designating Emergency Medical Services Week; and

**WHEREAS**, with this year's national theme for Emergency Medical Services Week – ***"Beyond the Call."***

**NOW THEREFORE BE IT RESOLVED** that the Dare County Board of Commissioners in recognition of this event does hereby proclaim the week of May 19-25, 2019, as **EMERGENCY MEDICAL SERVICES WEEK.**

This the 7<sup>th</sup> day of May, 2019





*Report from the A.B.C. Board*

**Description**

Ray White, Chairman of the Dare County A.B.C. Board will present a report to the Board of Commissioners.

**Board Action Requested**

None - Information Presentation Only

**Item Presenter**

Ray White, Chairman, Dare County A.B.C. Board

Exhibit A						
Dare County ABC Board Net Profit Report and State Ranking						
	Profit % to Sales	State Rank				
2018	13.32	7				
2017	13.36	7				
2016	14.08	6				
2015	14.88	3				
2014	12.57	9				
2013	13.40	3				
2012	10.94	11				
2011	12.15	5				
2010	11.96	10				
2009	12.87	8				
*2006	19.72	**1				
*Ranking is out of 168 ABC Boards with a total of 433 ABC Stores						

# EXHIBIT B

**TOTAL  
REVENUE  
DISTRIBUTION:  
\$430,635,861**

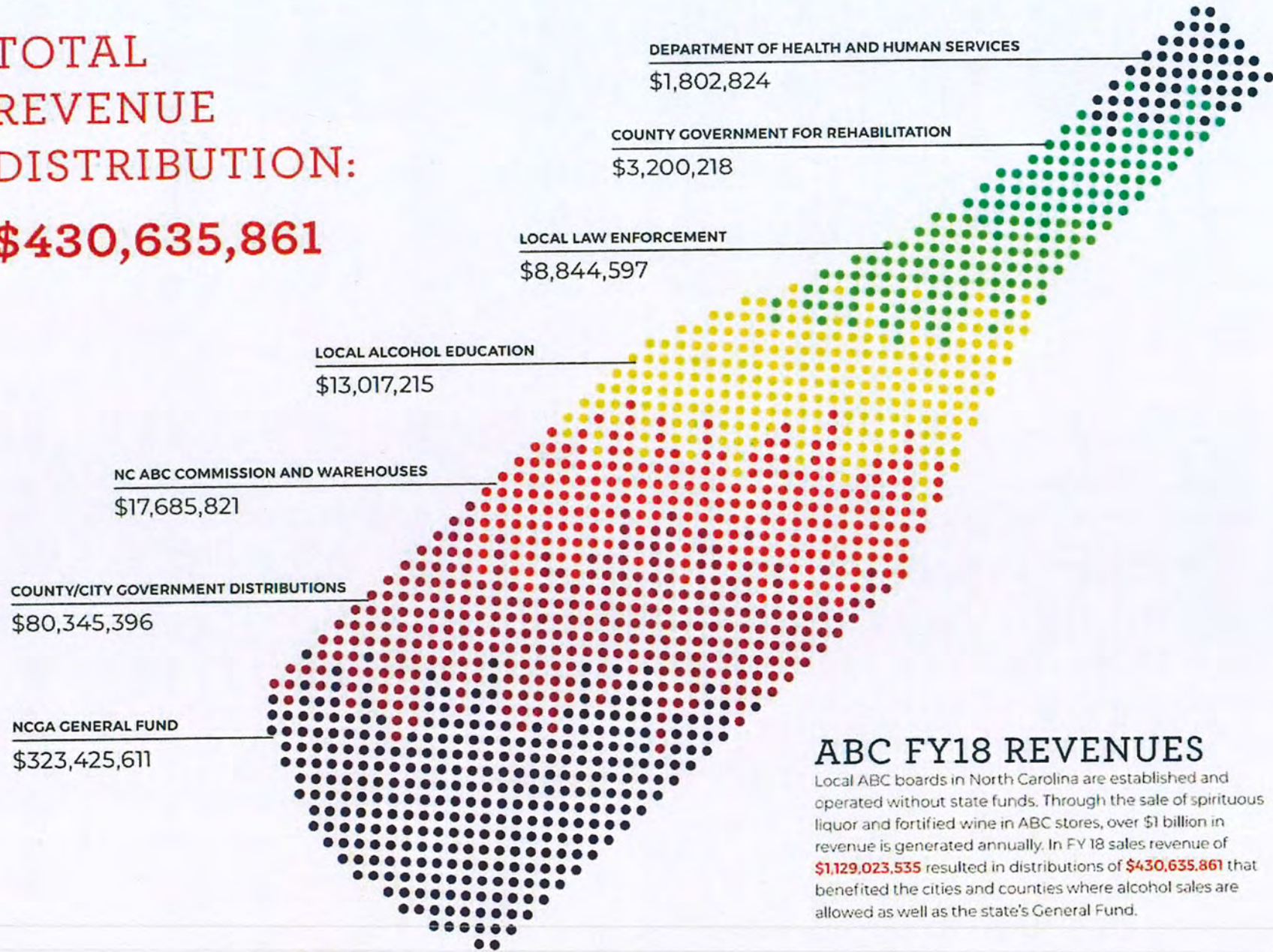

## ABC FY18 REVENUES

Local ABC boards in North Carolina are established and operated without state funds. Through the sale of spirituous liquor and fortified wine in ABC stores, over \$1 billion in revenue is generated annually. In FY 18 sales revenue of **\$1,129,023,535** resulted in distributions of **\$430,635,861** that benefited the cities and counties where alcohol sales are allowed as well as the state's General Fund.

RECURRING REVENUE DISTRIBUTION



Exhibit C			
10 Year Sales Report			
Fiscal Year	Retail Liquor Sales	Mixed Beverage Sales	Total Sales
2017-18	\$ 13,565,635.00	\$ 4,040,090.00	\$ 17,605,725.00
2016-17	\$ 13,287,257.00	\$ 3,849,640.00	\$ 17,136,897.00
2015-16	\$ 12,650,013.00	\$ 3,793,176.00	\$ 16,443,189.00
2014-15	\$ 11,902,415.00	\$ 3,620,064.00	\$ 15,522,479.00
2013-14	\$ 11,238,762.00	\$ 3,445,944.00	\$ 14,684,706.00
2012-13	\$ 10,756,537.00	\$ 3,327,043.00	\$ 14,083,580.00
2011-12	\$ 10,406,118.00	\$ 3,240,419.00	\$ 13,646,537.00
2010-11	\$ 10,142,237.00	\$ 2,835,735.00	\$ 12,977,972.00
2009-10	\$ 9,810,292.00	\$ 2,563,158.00	\$ 12,373,450.00
2008-09	\$ 9,563,469.00	\$ 2,797,188.00	\$ 12,360,657.00

Exhibit D										
10 Year Counties and Municipalities Distribution Report										
	State Rank	Profit %	County of Dare	Town of Duck	Town of Kitty Hawk	Town of Kill Devil Hills	Town of Manteo	Town of Nags Head	Town of Southern Shores	
2017-18	7	13.32	\$ 1,442,560.00	\$ 58,384.00	\$ 58,384.00	\$ 58,384.00	\$ 58,384.00	\$ 58,384.00	\$ 58,384.00	\$ 58,384.00
2016-17	7	13.36	\$ 1,402,689.00	\$ 56,390.00	\$ 56,390.00	\$ 56,390.00	\$ 56,390.00	\$ 56,390.00	\$ 56,390.00	\$ 56,390.00
2015-16	6	14.08	\$ 1,418,552.00	\$ 56,482.00	\$ 56,482.00	\$ 56,482.00	\$ 56,482.00	\$ 56,482.00	\$ 56,482.00	\$ 56,482.00
2014-15	3	14.88	\$ 1,415,634.00	\$ 55,377.00	\$ 55,377.00	\$ 55,377.00	\$ 55,377.00	\$ 55,377.00	\$ 55,377.00	\$ 55,377.00
2013-14	9	12.57	\$ 1,104,317.00	\$ 49,646.00	\$ 49,646.00	\$ 49,646.00	\$ 49,646.00	\$ 49,646.00	\$ 49,646.00	\$ 49,646.00
2012-13	3	13.4	\$ 1,142,162.00	\$ 49,156.00	\$ 49,156.00	\$ 49,156.00	\$ 49,156.00	\$ 49,156.00	\$ 49,156.00	\$ 49,156.00
2011-12	11	10.94	\$ 878,318.00	\$ 45,026.00	\$ 45,026.00	\$ 45,026.00	\$ 45,026.00	\$ 45,026.00	\$ 45,026.00	\$ 45,026.00
2010-11	5	12.15	\$ 955,329.00	\$ 48,129.00	\$ 48,129.00	\$ 48,129.00	\$ 48,129.00	\$ 48,129.00	\$ 48,129.00	\$ 48,129.00
2009-10	10	11.96	\$ 903,381.00	\$ 46,176.00	\$ 46,176.00	\$ 46,176.00	\$ 46,176.00	\$ 46,176.00	\$ 46,176.00	\$ 46,176.00
2008-09	8	12.87	\$ 964,351.00	\$ 47,717.00	\$ 47,717.00	\$ 47,717.00	\$ 12,613.00	\$ 47,716.00	\$ 47,716.00	\$ 47,716.00
			\$ 11,627,293.00	\$512,483.00	\$512,483.00	\$ 512,483.00	\$477,379.00	\$ 512,482.00	\$ 512,482.00	\$ 14,667,085.00
10 year total revenue distributions for the County and Municipalities \$ 14,667,085										
An additional \$12,000.00 is given annually to the Dare County Sheriff's Department for alcohol education.										

Exhibit E 2018					
Surrounding Counties	State Rank	Net Profit %	# of Stores	County/Municipal Distributions	Sales
Dare	7	13.32%	5	\$ 2,045,543	\$ 17,727,401
Pasquotank	8	13.16%	1	\$ 393,366	\$ 3,568,227
Currituck	33	10.69%	3	\$ 634,954	\$ 5,922,076
Tyrell	137	4.16%	1	\$ -	\$ 460,594
Camden	127	5.09%	2	\$ 64,368	\$ 1,442,263
Hyde	111	5.92%	2	\$ 67,580	\$ 798,758
Select Others					
Carteret	16	12.27%	6	\$ 1,037,961	\$ 14,911,891
Onslow	45	9.60%	6	\$ 996,549	\$ 18,062,865



*Closed Session*

**Description**

The Dare County Board of Commissioners will go into Closed Session pursuant to provisions of the North Carolina General Statutes (NCGS) as specified by the County Manager.

**Board Action Requested**

Approve Going Into Closed Session

**Item Presenter**

County Manager, Robert Outten



*Contract for Dare County Dredge Vessel*

**Description**

The Board of Commissioners will review the contract pertaining to the acquisition of a dredge vessel for Dare County

**Board Action Requested**

Discuss and take appropriate action

**Item Presenter**

Robert Outten, County Manager



**DREDGE WORK PLAN AND FORGIVABLE LOAN AGREEMENT**

**THIS AGREEMENT** made and entered into this the \_\_\_\_ day of \_\_\_\_\_, 20\_\_ by and between EJE Recycling Disposal, Inc., and EJE Dredging Service, LLC, each organized and existing under the laws of the State of North Carolina (hereinafter collectively known as “EJE”), and Dare County, a political subdivision organized and existing pursuant to the laws of the State of North Carolina (hereinafter “County”).

**WITNESSETH:**

**WHEREAS**, EJE has agreed to design, have constructed, operate and maintain a new ocean certified, shallow draft, special purpose, split-hull hopper dredge vessel (the “Dredge”), in cooperation with and with guidance from County through the Oregon Inlet Task Force (hereinafter “OITF”); and

**WHEREAS**, EJE has agreed to provide dredging services for Oregon Inlet, Hatteras Inlet and the other shallow draft inlets of North Carolina as directed by the OITF and as provided under the terms of this Agreement and in compliance the provisions of Senate Bill 99, Section 13.7(a-h) of the 2017 Session Laws of the NC General Assembly.

**NOW, THEREFORE**, in consideration of the terms and conditions set forth herein, the sufficiency of which is hereby acknowledged, the parties hereto agree as follows:

**ARTICLE I:**

**FORGIVEABLE LOAN**

- A. County shall, pursuant to the provisions of Senate Bill 99, Section 13.7(a-h) of the 2018 Session Laws of the NC General Assembly, (the “Enabling Legislation”) lend to EJE the principal sum of FIFTEEN MILLION and 00/100 Dollars (\$15,000,000.00) pursuant to the terms of the Promissory Note attached hereto as Exhibit A,
- B. County’s loan to EJE is contingent upon the appropriation and receipt by the County of FIFTEEN MILLION and 00/100 Dollars (\$15,000,000.00) from the State of North Carolina as provided in the Enabling Legislation. In no event shall County have any obligation, duty, or liability to lend or provide funds other than the sums received from the State of North Carolina pursuant to the Enabling Legislation. The loan proceeds from County to EJE shall be disbursed pursuant to the Draw Schedule attached as Exhibit A to the Promissory Note.
- C. The loan proceeds shall be used by EJE exclusively for the costs necessary to design, build and equip the Dredge, suitable for use in Oregon Inlet, Hatteras Inlet and other shallow draft inlets of the state, having a minimum capacity of 500 cubic yards, and capable of removing 1 million cubic yards of sand per year under normal operating conditions.

- D. The obligations of the Maker under the terms of the aforesaid Promissory Note and all attachments to the Promissory shall be secured by a Preferred Ship Mortgage, in a first lien position (unless agreed otherwise) upon the Dredge, It shall be the responsibility of the County to prepare and file all documents related to a Preferred Ship Mortgage, EJE shall, prior to delivery of the Dredge, provide County with a list of all equipment and furnishings to include a complete list of vendors and suppliers. . EJE shall provide all information and execute all documents required by County necessary to the County's preparation, perfecting and filing of a Preferred Ship Mortgage and a security interest in all equipment, furnishings as built plans and drawings, as built specifications, and operations manuals associated with the Dredge. The Preferred Ship Mortgage and security agreement will be in a form and contain provisions substantially similar to Exhibit B attached.
- E. By execution hereof, as additional security for its obligations under the terms of this agreement and its exhibits, the Promissory Note and its exhibits, and the agreements to be assigned, EJE shall execute an assignment of all documents necessary to design, construct, own, and operate the Dredge including, but not limited to, the architect's contract, the construction manger's contract, the Dredge builder's contract, the license for the design documents, operations manuals, all as provided in the Assignment Agreement attached hereto as Exhibit C.

## **ARTICLE II:**

### **DREDGE CONSTRUCTION**

- A. EJE Dredging Services, LLC, with approval of the County through the OITF, such approval not being unreasonably withheld, shall select a naval architect and a construction project manager, neither associated with the dredge builder, to assist in the design and supervision of construction, the Dredge. The plans and specifications for the vessel shall be developed by EJE Dredging Services, LLC and its architect in consultation with the County through the OITF. The County through the OITF shall have final approval of all plans and specifications. The contracts between EJE and the architect and between EJE and the project manager shall be approved by County through the OITF prior to execution by EJE.
- B. The final plans and specifications shall be approved by County through the OITF prior to EJE entering a contract with builder. Upon approval of the final plans and specifications by County through the OITF, EJE and the project manager shall prepare and advertise an RFQ seeking qualified builders to submit their qualifications and experience in building dredges similar to the specifications provided. EJE Dredging Services, LLC shall select the builder from those responding, and negotiate a construction contract to construct the dredge as specified. The terms of the construction contract, exclusive of construction costs, shall be approved by County through the OITF prior to execution by EJE Dredging Services, LLC . County through the OITF may approve or disapprove at its discretion for any reason or no reason.

- C. The dredge shall be constructed in the United States, and the dredge shall be documented by the United States Coast Guard.

The dredge shall be titled in the name of, and owned and operated by, EJE Dredging Services, LLC, a North Carolina corporation based exclusively in the United States Without changing the liability, duties and obligations of EJE Recycling Disposal, Inc. under the terms of this agreement, the Promissory note or any other written agreements to which EJE Recycling Disposal, Inc. is a party, with the approval of the State of North Carolina, County may pay draws of the loans proceeds directly to EJE Dredging Services, LLC

- D. In the event County through the OITF is unwilling in its sole discretion, to approve the plans and specifications or the terms and conditions of the contracts specified in Paragraphs A-D above for any reason or no reason, within 90 days from written notice to EJE by County that such approvals shall not be given, the deliverables that have been created under the aforesaid contracts shall be delivered by EJE to County and they become the property of County, EJE shall provide County an accounting of all sums received and disbursed, and EJE shall return any unspent funds or funds improperly spent (collectively “excess funds”) to County. Upon receipt of the deliverables and the repayment of excess funds within the time specified, this agreement shall terminate and the outstanding balance under the terms of the Promissory Note shall be waived and neither party shall have any other or further obligation or liability to the other. Upon EJE’s failure to deliver to County the deliverables and excess funds within the specified time, EJE shall be deemed in default and County may exercise all remedies available at law, in equity, and under the terms of this agreement, the Promissory Note, or any of the other documents executed by the parties.

### **ARTICLE III:**

#### **DREDGE OPERATIONS**

- A. EJE Dredging Services, LLC shall own, keep, operate and maintain the dredge at its own expense. EJE shall be responsible for all liabilities associated with the dredge and its operation. EJE shall own and operate the dredge in compliance with all applicable Federal, State and local laws, rules, codes, regulations, and permits (“applicable law”), and EJE shall indemnify and hold harmless the County from any loss, fine, penalty or any other liability from same. Provided, however, nothing herein shall operate to require EJE to indemnify the County for the County’s own negligence.
- B. During the term of this Agreement, together with any extensions, EJE Dredging Services, LLC shall keep the dredge insured at all times in an amount equal to the replacement cost to construct and equip a similar dredge, shall maintain workers compensation insurance on its employees as required by state and federal statutes, shall carry commercial and marine liability insurance in an amount not less than Five Million Dollars and shall comply with all Jones Act coverage requirements.

- C. Upon delivery of the dredge, EJE Dredging Services, LLC shall perform, unless otherwise authorized by the County through the OITF, dredging operations exclusively in the waterways of the State of North Carolina, and at locations designated by the County through the OITF. EJE Dredging Services, LLC will only dredge as permitted by applicable permits.
- D. EJE Dredging Services, LLC agrees to operate the dredge pursuant to the terms of this agreement, from the date the dredge is delivered to EJE Dredging Services, LLC for a period of ten years or the loan repayment period plus any extensions, whichever is longer.. EJE s Dredging Services, LLC hall operate the dredge a minimum of 12 hours per day, 340 days per year, subject to weather conditions, maintenance, repair, mobilizations, permit conditions, funding limitations, or acts of God that may reduce the number of days of operation. Should EJE Dredging Services, LLC’s operations be subject to a permit(s) with dredging “windows”, EJE Dredging Services, LLC shall operate the dredge 24 hours per day during the work “windows” established by the relevant permit(s), subject to weather conditions, maintenance, repair, mobilizations, funding limitations or acts of God.
- E. Upon delivery of the dredge, and prior to beginning any dredging operations, EJE Dredging Services, LLC shall employ, and at all times thereafter keep in its employ, such captain(s), experienced in dredge operations, and such crew as may be necessary to operate the dredge on the schedule set forth above. Preference in hiring shall be given to captain(s) experienced in dredge operations in Oregon Inlet, Hatteras Inlet, and the waterways of the State of North Carolina. All Captains and other crew shall at all times have all required licenses and certifications to operate the dredge as provided herein.

During the term of this Agreement, the parties agree that the “usual and customary rates” for dredging services as of the date the last party executes this agreement shall be:\$14.33 per cubic yard of material loaded and placed in a permitted disposal area and for material removed from Hatteras Inlet and placed in a permitted disposal area(s), each inclusive of survey boat costs, with the exception of the following:

\$19.58 per cubic yard of material loaded from inside the bar and placed in a permitted disposal area outside the bar, inclusive of survey boat costs.

The line of demarcation between “inside the bar” and “outside the bar” shall be a line a one nautical radius east of the center of the Marc Basinight Bridge.

“Inside the bar” shall be the permitted disposal area generally west of “landward” of the line of demarcation and “outside the bar” shall be any permitted disposal area generally east (seaward) of the line of demarcation.

These rates shall be deemed the Base Rates. The Discounted Rate shall be a minimum of \$1.50 per cubic yard less than the applicable Base Rate. The Base Rate will adjust up or down annually on the 1<sup>st</sup> day of October each year by the same percentage as the average percentage change in the US Army Corps of Engineers daily rate for the Dredge Murden

(or its equivalent if the Murden is not operational for a period in excess of 6 months during the previous 12 months) for the previous 12 month period.

- G. EJE shall charge Dare County not greater than the Discounted Rate for materials removed from Oregon Inlet, Hatteras Inlet and vicinity, and the waterways of Dare County, up to the aggregate \$3 million dollars of County funding annually for Oregon Inlet and \$250,000 dollars of County funding annually for Hatteras Inlet based upon cubic yards of material removed. EJE Dredging Services, LLC shall not perform work in excess of the forgoing budgeted amount without the approval of the County. It is acknowledged that the State of North Carolina maintains a Shallow Draft Inlet Management Fund which currently provides a 2/3 match to local funding for shallow draft inlet projects in Tier 2 and Tier 3 counties and a 3/4 match to local funding for shallow draft inlet projects in Tier 1 counties. The 2/3 and 3/4 matches are the “state share” For projects within North Carolina waters, but outside of Dare County, (exclusive Hatteras Inlet a portion of which is in Hyde County) EJE Dredging Services, LLC may charge a negotiated rate per cubic yard of material removed not to exceed the base rate as adjusted. If permitted by County through the OITF to dredge outside North Carolina, EJE Dredging Services, LLC may charge a negotiated rate based upon cubic yards of material removed for projects outside North Carolina waters.
- H. It is the intent of the parties that EJE Dredging Services, LLC shall perform dredging operations only in the waterways of North Carolina unless otherwise authorized and approved in advance by County through the OITF. If, however, at any time during the terms of this Agreement, no dredging permits or funds are available for dredging operations in the waterways of North Carolina, the County through the OITF shall, if authorized by law, approve a request by EJE Dredging Services, LLC to perform dredging operations in the waterways of adjacent states until permits and/or funding becomes available for dredging in North Carolina waters. Further, EJE Dredging Services, LLC shall perform dredging operations in the waterways of North Carolina in locations and at times designated by the County through the OITF, and EJE shall not perform dredging operations in any waterway not approved by the County through the OITF. All dredging operations shall be performed to the permitted specifications of the waterway being dredged and in compliance with all permits, rules, and regulations, State and Federal.
- I. EJE Dredging Services, LLC shall keep the following records monthly, shall provide these monthly records with each invoice, and make these records available to County at any other time upon request:
1. Month, year and Location dredging was performed;
  2. Total vessel time billed;
  3. Total cost for each month;
  4. Total dredge and haul each month;
  5. Cost per dredge and haul hour;
  6. Monthly production by cubic yard;
  7. Production per dredge hour and haul hour in cubic yards;
  8. Production cost per cubic yard; and

9. Times, dates duration of weather, and explanation of mechanical and other delays.
10. A Hopper Dredge Quality Control Report containing the information and in substantially the same form as Exhibit D.

J. EJE Dredging Services, LLC shall bill for its services to the following address: **[Need Input to Address]**.

K. County shall approve or make objection to any invoice received within 10 business days after receipt. Within 15 days after receipt County shall remit payment of its share of such invoice and shall request the State to remit its share of such invoice unless the invoice is contested. County will remit the state share upon receipt from state. County shall have no obligation to take legal or other actions to collect the state share but agrees to cooperate with EJE Dredging Services, LLC in EJE Dredging Services, LLC's efforts to collect the state share, including the assignment to EJE Dredging Services, LLC of the county's right, if any, to collect the state share. EJE Dredging Services, LLC shall be responsible for all costs and expense associated with the collection of the State share and shall hold County harmless from same. In no event shall County be liable to EJE Dredging Services, LLC for the state share.

L. In the event an invoice is contested, County shall pay, and shall request the State to pay, their respective shares of any uncontested amount. The parties agree to use reasonable efforts to resolve any contested amounts, but EJE Dredging Services, LLC may, within 60 days of date of the invoice, request mediation pursuant to the American Arbitration Association rules and procedures. If mediation is not requested within 60 days from the date of the invoice, EJE Dredging Services, LLC will be deemed to have waived the contested portion of the invoice. In the event the disputed invoice is submitted to but not resolved in mediation, any party may institute legal proceedings in a court of competent jurisdiction in the State of North Carolina.

M. Dare County, North Carolina shall be the homeport of the dredge. When the dredge is not in operation, it shall be docked in Dare County. When performing dredging operations in other waters, however, the dredge may be docked in those areas during the term of those dredging operations.

N. EJE Dredging Services, LLC at all times after delivery of dredge and during the term of this Agreement, together with any extensions thereto, shall own or lease, or have a valid, written access agreement for dock space in Dare County and shall provide evidence of same to County annually and upon request.

O. During the term of this Agreement, together with any extensions thereto, EJE shall obtain and maintain a written agreement with, the North Carolina Ferry Division for the use of the NC Ferry Division's dry dock located in Manns Harbor, North Carolina, to haul the dredge vessel for maintenance and repair. Alternatively, EJE Dredging Services, LLC may enter into a written agreement with another facility in Dare County, North Carolina capable to perform repairs and maintenance as needed. The dredge shall not leave the

waters of Dare County, North Carolina for maintenance or repair without the prior approval of the County through its Oregon Inlet task Force.

#### **ARTICLE IV:**

#### **OTHER TERMS**

- A. The terms of this Agreement shall begin upon the date set forth above and shall remain in effect for a minimum of 10 years from the date of delivery of the Dredge to EJE or until the date all sums due under the Promissory Note and any extensions thereto have been repaid, forgiven or otherwise satisfied, whichever is longer.
- B. Any funds used by EJE in furtherance of the dredge construction project shall be used at EJE's risk, and in no event shall the State of North Carolina or County shall be liable to EJE for same.
- C. County shall be responsible for obtaining the environmental permits necessary to dredge in Oregon Inlet and Hatteras Inlet, and to place dredged materials. Obtaining environmental permits to dredge any other waterway of the State of North Carolina or any other state shall be the responsibility of the entity requesting the dredging operations. All other permits, licenses or approvals necessary to operate the dredge shall be the responsibility of and be obtained by EJE.
- D. Notwithstanding any agreement to the contrary, the County's only financial obligations to EJE are: (1) to administer the forgivable loan from the funds provided by the state; and (2) to pay for the County's 1/3 or 1/4 share respectively, or the local match requirement pursuant to statute or regulation, for dredging services in Oregon Inlet and Hatteras Inlet, actually performed, for agreed upon quantities, and at the rates set forth in this Agreement, not to exceed \$3,000,000.00 annually for Oregon Inlet and \$250,000.00 annually for Hatteras Inlet..
- E. This Agreement constitutes the entire agreement of the parties, and may not be changed except by written amendment duly executed by the parties.
- F. This Agreement shall be binding upon each of the parties' respective heirs, executors, administrators, successors and assigns.
- G. Should the County or EJE breach this Agreement by failing to perform in strict accordance with the terms of this Agreement, the non-breaching party shall provide the breaching party with a written notice of default, served by U.S. Certified Mail. Should the defaulting party within five (5) days after receipt of written notice of default fail to commence and continue satisfactory correction of such default with diligence and promptness, then the non-breaching party may avail itself of all remedies, at law or in equity, which it may have under this Agreement or as otherwise provided by law.
- H. Except actions necessary to enforce the terms of the Preferred Ship Mortgage, this Agreement shall be governed by the laws of the State of North Carolina, and jurisdiction

for any legal proceedings arising from this agreement shall be the North Carolina General Court of Justice with in Dare County, North Carolina.

- I. Neither this Agreement nor the duties and obligations set forth in this Agreement may be assigned, whether by purchase, grant, or otherwise, by either party, except as specifically specified herein, without the prior written consent of the other party. Notwithstanding the forgoing provisions, the parties hereto agree that ownership of the vessel constructed pursuant to this Agreement as well the responsibility for the dredging operations specified in this Agreement, may be assigned, once the vessel's construction is completed, to EJE Dredging Service, L.L.C.
- J. Each provision of this Agreement is separate from the other provisions of this Agreement. If any provision is determined to be unenforceable, all other provisions shall remain in full force and effect.
- K. The parties agree that they shall execute any further documents and will perform any further acts that are or may become necessary to effectuate the intent of the parties expressed herein.
- L. Breach by EJE of any of the conditions of the Promissory Note, the attachments thereto, the Ships Mortgage contemplated herein, the contracts between EJE and others for which County has approval rights, and any other documents, agreements, security agreements contemplated herein, shall be deemed a breach of this agreement and a breach and an event of default in all other agreements between the parties.
- M. Contingencies
  - 1. EJE's performance of its obligations under terms of this agreement are contingent upon:
    - 1) The receipt by County permits satisfactory to EJE to authorize dredging in Oregon Inlet.
    - 2) Approval by EJE of the Dredge construction contract for any reason or no reason.
    - 3) EJE shall exercise its right to terminate under these provisions by issuing written notice to County within 30 days from the date the permit was issued as to contingency 1 above and within 30 days from the date the proposed construction contract is received by EJE if as to contingency 2 above. Failure to provide written notice with the time specified shall be deemed a waiver of these contingencies. 3) Upon proper termination by EJE it shall, within 90 days from its written notice to terminate, deliver to County the deliverables that have been created and they shall become the property of County, provide County an accounting of all sums received and disbursed,



return any unspent funds or funds improperly spent (collectively “excess funds”) to County, give notice to the appropriate parties of County’s right to exercise the assignment provisions of Exhibit C to this agreement. Upon receipt of the deliverables, reconciliation of the accounting, the repayment excess funds, and notice to the appropriate parties relative to the assignment, each within the time specified, this agreement shall terminate and the outstanding balance under the terms of the Promissory Note shall be waived and neither party shall have any other or further obligation or liability to the other. Upon EJE’s failure to deliver to County the deliverables, the accounting, the repayment excess funds, and notice to the appropriate parties relative to the assignment within the specified time, EJE shall be deemed in default and County may exercise all remedies available under the terms of this agreement, the Promissory Note, or any of the other documents executed by the parties and may exercise any other remedy at law or in equity.

- N. EJE shall comply with all terms and conditions of the Memorandum of Agreement between the State of North Carolina and County (the “State Agreement”) which sets forth, among other things, the terms and conditions of the transfer and use of the Fifteen Million and 00/100 dollars (\$15,000,000.00) by County to EJE. EJE shall use the loan proceeds only for purposes permitted in the State Agreement. EJE shall keep all documents and records associated with the use of the loan proceeds and make those records available to the State or county at any time, upon request. Such records shall include receipts, invoices, contracts, checks, wiring receipts and all other documents associated with the expenditure of the loan proceeds and shall follow and be in accordance with generally accepted accounting principles, practices and procedures. The State Agreement is attached hereto as Exhibit E and incorporated herein by reference as if fully set out.
  
- O. In the event that at any time during the terms of this agreement, the promissory note or extensions thereto, or any other written agreements to which EJE Recycling Disposal, Inc. is a party, EJE Recycling Disposal, Inc. shall dispose, whether voluntarily or involuntarily, more than 20% of the value of its assets as shown on its financial statements for year end 12/31/2018, Judson T. Whitehurst joins in the execution of this agree to, in that event and in that event only, personally guarantee the liabilities, duties, performance and obligations of EJE Recycling Disposal, Inc. under the terms of this agreement, the promissory note and any other agreements to which EJE Recycling Disposal, Inc. is a party.

IN WITNESS WHEREOF, the Parties have caused this instrument to be signed and sealed the day and year first above written.

E.J.E RECYCLING DISPOSAL, INC.

By: \_\_\_\_\_ (SEAL)  
Judson T. Whitehurst, President

EJE DREDGING SERVICE, LLC

By: \_\_\_\_\_ (SEAL)  
Judson T. Whitehurst, Manager

By: \_\_\_\_\_ (SEAL)  
Judson T. Whitehurst, Individually

DARE COUNTY

By: \_\_\_\_\_ (SEAL)  
Chairman, Dare County Board of Commissioners

Attest: \_\_\_\_\_  
Clerk

**PROMISSORY NOTE**

\$15,000,000.00

Manteo, North Carolina  
March \_\_\_\_, 2019

FOR VALUE RECEIVED, E.J.E. Recycling Disposal, Inc., a North Carolina corporation and EJE Dredging Service, LLC, a North Carolina limited liability company (hereinafter collectively, “Maker”), jointly and severally promise to pay to the order of Dare County, a political subdivision organized and existing pursuant to the laws of the State of North Carolina (“Payee”), at P.O. Box 1000, 954 Marshall Collins Dr., Manteo, North Carolina 27954 or at such other place or to such other party or parties as the holder of this Note may from time to time designate, the principal sum of FIFTEEN MILLION and 00/100 Dollars (\$15,000,000.00), together with interest at the rates designated herein, computed on the basis of a 365 day year for the actual number of days in each interest period, both principal and interest payable in lawful money of the United States which shall be legal tender in payment of all debts and dues, public and private at the time of payment by bank wire or by check. Until an Event of Default, this promissory note (the “Note”) shall bear interest at a rate of two percent (2.0%) per annum. The loan proceeds are to be applied to the costs to design and build an ocean certified, shallow draft, special purpose, split-hull hopper dredge vessel (the “Dredge”) and secured as provided herein. The aforesaid sum shall be disbursed to Maker in draws pursuant to the Draw Schedule attached hereto as Exhibit A and incorporated herein by reference as if fully set out. Principal and interest shall be calculated and paid as follows:

- A. Interest at the aforesaid rate shall begin accruing, as provided in Paragraph C below, on any outstanding principal balance on the date that the fully operable Dredge is physically delivered and titled to Maker (the “Interest Commencement Date”). Maker and Payee agree to execute, as soon as practicable, a written statement specifying the Interest Commencement Date in the form attached hereto as Exhibit B (the “Interest Commencement Date Agreement”). If Maker fails to execute and deliver such agreement within thirty (30) days of receipt of written request by Payee to execute such agreement, Maker shall be conclusively deemed to have acknowledged and agreed with Payee’s determination of the Interest Commencement Date, as set forth on the Interest Commencement Date Agreement sent to it by Payee.
  
- B. As long as there has not been an Event of Default under this Note, during the initial term of this Note and any extension thereto, Payee shall forgive that portion of the principal in an amount equal to the difference between the Base Rate and Discounted Rate for services which were provided to Payee under the terms of the Dredge Work Plan and Forgivable Loan Agreement between the parties dated the \_\_\_\_ day of \_\_\_\_\_, 20\_\_ (the “Work Plan”) which is incorporated herein by reference as if fully set out.
  
- C. If not sooner paid or upon default, Maker shall repay all outstanding principal, together with accrued interest at 2% per annum from the interest commencement date, in one lump sum on the first day of the one hundred twentieth (120th) month following the Interest Commencement Date or such later date as is provided in any amendment to this Note.

- D. Unless otherwise agreed in writing, each installment shall be applied: (i) first to any unpaid expenses of collection pursuant to Section \_\_\_\_\_ of this Note; then to the payment of interest then accrued and due on the unpaid principal balance, and then to any unpaid principal owed on this Note.
- E. Unless elsewhere defined in this Note, capitalized terms used herein shall have the meanings as defined in the Dredge Agreement.
- F. This Note may be prepaid in whole or in part at any time without penalty.

Maker shall repay all outstanding principal, together with interest at the rate of 2% per annum on the outstanding principal, in one lump sum on the first day of the 120<sup>th</sup> month following the delivery of the dredge vessel to Maker or on the due date provided in any requested loan extensions.

#### ARTICLE 1. EVENTS OF DEFAULT; REMEDIES

Section 1.1. *Events of Default.* The happening or continuing of any one or more of the following events or conditions shall be an “Event of Default” under this Note:

- (a) the failure of Maker to make a payment of interest or principal already due on this Note within the later of (i) 10 days after the same shall become due or (ii) 5 days after receipt of written notice of default hereunder;
- (b) the occurrence of an Event of Default under the Work Plan, any contract with the Naval Architect, the contract for the construction of the Dredge, any security agreement signed by Maker (or either of them), any preferred ship mortgage, any assignment of leases, rents and profits, or any written agreement by Maker related to the Dredge;
- (c) if Maker (or either of them) files a voluntary petition of bankruptcy, or a petition seeking reorganization or an arrangement with creditors or to take advantage of any bankruptcy, reorganization, insolvency, readjustment or debt, dissolution or liquidation law or statute, or an answer admitting the material allegations of a petition filed against it in a proceeding under such law;
- (d) if an order, judgment or decree shall be entered, without the application, approval or consent of Maker (or either of them), by any court of competent jurisdiction, approving a petition seeking reorganization or liquidation of Maker (or either of them) or a substantial part of the assets of Maker (or either of them), or appointing a receiver, trustee, custodian or liquidator of Maker (or either of them), and such order, judgment or decree shall not be dismissed within sixty (60) days;
- (e) If Maker (or either of them) applies for or consents to the appointment of a receiver, trustee, custodian or liquidator of itself or for all or a substantial part of its property;
- (f) If Maker (or either of them) makes a general assignment for the benefit of creditors;

(g) If Maker (or either of them) is adjudicated bankrupt or insolvent;

Section 1.2. *Acceleration.* Upon the occurrence of any Event of Default, Payee may, without further notice, declare the unpaid principal amount of this Note, together with all interest accrued thereon immediately due and payable. Failure to exercise this option shall not constitute a waiver of the right to exercise the same at any other time.

Section 1.3. *Default Interest Rate.* Upon the occurrence of any Event of Default and upon acceleration of the entire unpaid principal balance of the amount owed by the Maker to Payee hereunder, interest shall continue to accrue thereafter to the extent legally permissible at the rate of eight percent (8.00%) per annum, until the entire principal amount of this Note and any other amounts due hereunder shall have been paid in full, including the period following entry of any judgment. Both before and after any Event of Default, interest shall be computed on the basis of a 365-day year.

Section 1.4 *Expenses of Collection; Rights Cumulative.* Maker and any and all assumers, sureties, endorsers, or guarantors further agree, jointly and severally, that they will pay any collection expense, court costs and reasonable attorneys' fees, not exceeding a sum equal to fifteen percent (15%) of the outstanding balance owing on said Note, plus all other reasonable expenses which may be incurred in the collection or enforcement of the Note or any part hereof. The rights and remedies of the holder as provided in this Note and any instrument securing this Note shall be cumulative and may be pursued singly, successively, or together against any funds, property or security held by the holder for payment or security, in the sole discretion of the holder. The failure to exercise any such right or remedy shall not be a waiver or release of such rights or remedies or the right to exercise any of them at another time.

## ARTICLE 2. SECURITY

This Note shall be secured by a First Preferred Ship Mortgage on the Dredge, one or more Security Agreements on the Dredge and the personal property, equipment and fixtures related thereto, as well as an Assignment of Leases, Rents and Profits, Assignment of Construction Documents, Assignment of Contract with Builder, and Assignment of Architect Contract, all such documents being of even date herewith, to which reference is made for the terms thereof, and the same are hereby incorporated by reference and made a part of this Note. Nothing herein shall prohibit Payee, at its sole discretion, from subordinating all or part of its position on a Ship Mortgage or Security Agreement in favor of a bank or other financial institution. Payee agrees that upon request of Maker within 24 months from the date hereof, Payee will subordinate its position on a Ship Mortgage in favor a State or Federally licensed commercial lending institution in an amount not exceed \_\_\_\_\_ and for a term not exceed \_\_\_\_\_.

## ARTICLE 3. SPECIFIC WAIVERS; OFFSET

Section 3.1 *Specific Waivers.* Except as expressly provided herein, all parties to this Note, including Maker and all assumers, sureties, endorsers, guarantors (if any), and all persons liable or to become liable on this Note hereby jointly and severally waive: demand, protest, presentment, notices of presentment, nonpayment, protest, demand, and dishonor; and notice of acceleration of maturity, and also waive the benefit of any homestead exemption or any other

exemption. All such parties consent to any and all renewals and extensions of the time of payment hereof, agree to continue to remain bound for the payment of principal interest and all other sums due under this Note and further agree that at any time and from time to time without notice, the terms of payment herein, including the rate of interest applicable to this Note, may be modified or the security described in the lien documents securing this Note may be released in whole or in part, or increased, changed or exchanged by agreement between the holder or holders hereof and any owner of the premises affected by said lien documents securing this Note without in any way affecting the liability of any party to this instrument or any person liable with respect to any indebtedness evidenced hereby including any endorsers, guarantors, or accommodation parties. None of the rights and remedies of the holder or holders hereof are to be waived or affected by failure or delay to exercise them. Subject to the forgoing requirement, all remedies conferred on a holder by this Note or any other instrument or agreement shall be cumulative and none is exclusive. Such remedies may be exercised concurrently or collectively at the holder's option. **The holder of this Note shall first rely on the collateral for the payment of the Note in the event of default by the Makers prior to exercising other remedies. The holder shall use reasonable efforts to maximize the value of collateral to be applied to the payment of the Note.**

Section 3.2 No Right of Offset. Maker shall not be entitled to offset any sum which it owes Payee under this Note against any sum which Maker is owed by Payee.

#### ARTICLE 4. MISCELLANEOUS PROVISIONS

Section 4.1 Notices. All notices hereunder shall be in writing, shall specify the Section hereunder pursuant to which it is given or being made, and shall be deemed to have been duly given upon receipt or upon refusal by a party to accept receipt, whether delivered personally or by nationally recognized overnight courier or by certified or registered mail, postage prepaid, deposited in the United States Mail, return receipt requested, addressed to the parties at the addresses set forth below or at such other addresses as shall be specified in writing:

If to Payee: Dare County  
Attention: County Manager  
Post Office Box 1000  
954 Marshall Collins Drive  
Manteo,

If to Maker: EJE Dredging Service, LLC  
Attention: Judson T. Whitehurst  
802 Recycling Lane  
Greenville, NC 27834

And Poyner Spruill LLP  
Attention: Thomas H. Davis, Jr., Esq.  
301 Fayetteville Street, Suite 1900  
Raleigh, NC 27601

Section 4.2 Governing Law. This Note shall be governed by and construed in accordance with the laws of the State of North Carolina, without reference to that state's choice of law rules.

Section 4.3. Severability. Should any one or more of the provisions of this Note or of any agreement entered into pursuant to this Note be determined to be illegal or unenforceable, all other provisions of this Note and of each such other agreement shall be given effect separately from the provision or provisions determined to be illegal or unenforceable and shall not be affected thereby.

Section 4.4 No Assignment. Maker's obligations hereunder may not be assigned by operation of law or otherwise, except with the written permission of the Payee, its successors and assigns, which consent may be withheld in Payee's sole discretion. If such consent is given, Maker shall not be relieved of any of the obligations under this Note, and shall cause the assignee to perform all of the respective obligations hereunder to the same extent as if such assignment had not occurred, and Payee, its successors and assigns may be, at its sole election, entitled to enforce all of the duties and obligations under this Note of the other party against either or both of such other party and its assignee. Any attempted assignment by Maker in violation hereof shall be null and void. Payee's rights hereunder may be assigned upon written notice to Maker.

Section 4.5. General Waivers. Any waiver of a provision of this Note must be in writing signed by the party waiving its rights and shall apply only in the specific instance and for the specific purpose given. The giving of a waiver in one instance or for one purpose shall not create any implied obligation to give a waiver in another instance or for another purpose.

Section 4.6 Benefit. This Note is for the benefit of and may be enforced only by the parties hereto, and is not for the benefit of any other person or entity, including without limitation any employees of the Maker, and may not be enforced by any such third party.

Section 4.7 NO TRIAL BY JURY. ALL PARTIES TO THIS NOTE WAIVE ANY AND ALL RIGHT TO A TRIAL BY JURY IN ANY ACTION OR PROCEEDING BROUGHT OR COMMENCED BY EITHER PARTY WHICH IS DIRECTLY OR INDIRECTLY RELATED TO THIS NOTE. BY EXECUTION OF THIS NOTE, MAKER HEREBY REPRESENTS THAT IT IS REPRESENTED BY COMPETENT COUNSEL WHO HAS FULLY AND COMPLETELY ADVISED MAKER OF THE MEANING AND RAMIFICATIONS OF THE WAIVER OF THE RIGHT TO A TRIAL BY JURY.

Section 4.8 Jurisdiction and Venue. Maker (a) submits to personal jurisdiction in the State of North Carolina, the courts thereof and the United States District Courts sitting therein, for the enforcement of this Note, (b) waives any and all rights under the law of any jurisdiction to object on any basis (including, without limitation, inconvenience of forum) to jurisdiction or venue within the State of North Carolina for the purpose of litigation to enforce this Note, and (c) agrees that service of process may be made upon it in any manner prescribed by applicable federal rules of civil procedure or by applicable local rules or law of civil procedure for the giving of notice to the undersigned. Nothing herein contained, however, shall prevent Payee from bringing any action or exercising any rights against any security and against the undersigned personally, and against any assets of the undersigned, within any other state or jurisdiction.

Section 4.9 *Construction of Note.* This Note is the product of negotiations between Payee and Maker and their respective attorneys, and no provision shall be construed for or against either party by reason of ambiguity in language.

Section 4.10 *Headings.* The headings in this Note are for convenience of reference only and shall not constitute a part of this Note not be construed to alter or vary the text.

Section 4.11 *Attorneys.* In any action between Payee and Maker at law or in equity arising out of or related to this Note, the prevailing party shall be entitled to reasonable attorney's fees and court costs, in addition to any other relief to which that party may be entitled.

Section 4.12 *Reproduction of Documents.* Maker acknowledges that Payee may reproduce (by electronic means or otherwise) this Note or any of the documents evidencing and/or securing this Note and thereafter may destroy the original documents. Maker hereby agrees that any document so reproduced shall be the binding obligation of Maker enforceable and admissible in evidence against him to the same extent as if the original documents had not been destroyed.

Section 4.13 *Entire Agreement.* Except as may otherwise be specifically provided herein, this Note and the documents referred to in Article 2 of this Note constitute the entire agreement of the parties with respect to the debts owed by Maker to Payee, and all prior representations, covenants, proposals and understandings, whether written or oral, not contained in such documents are superseded and merged herein. This Note may be modified or amended only by an instrument in writing executed by the parties hereto and specifically stating that is intended as a modification or amendment to this Note. No oral statements or representations not contained herein shall have any force or effect.

IN WITNESS WHEREOF, the Makers have caused this instrument to be signed and sealed the day and year first above written.

E.J.E RECYCLING DISPOSAL, INC.

By: \_\_\_\_\_ (SEAL)  
Judson T. Whitehurst, President

EJE DREDGING SERVICE, LLC

By: \_\_\_\_\_ (SEAL)  
Judson T. Whitehurst, Manager

**Exhibit A**

**LOAN DRAW SCHEDULE**



<u>DRAW #</u>	<u>PURPOSE</u>	<u>EJE</u>	<u>LOAN</u>	<u>TOTAL AMOUNT</u>
---------------	----------------	------------	-------------	---------------------

The first draws are to be the draws for the expenses or portions of the expenses prior to EJE's execution of a contract with the ship builder, not to exceed \$500,000 and are without EJE contribution. (prior to the final draft for execution we need to identify and list these items)

The remaining draws are to be scheduled pursuant to the contract between EJE and the ship builder. EJE will contribute to each of these draws in a percentage of the draw amount equal to the percentage of the ships total construction cost not covered by the loan funds remaining after the initial draws. For example, if the ship costs \$28 mil to build, \$500k has been spent on preconstruction costs leaving \$14.5 mil of loan proceeds. Then EJE's share of each draw would be 48%. (\$28,000,000 - \$14,500,000 = \$13,500,000 (EJE share) divided by \$28,000,000 = .48)

No draws will be given until previous draw has been reconciled and approved by County.

TOTAL DRAWS

\$15,000,000.00

**Exhibit B**

**INTEREST COMMENCEMENT DATE AGREEMENT**

THIS INTEREST COMMENCEMENT DATE AGREEMENT, made as of the \_\_\_\_\_ day of \_\_\_\_\_, 2019, by and between E.J.E RECYCLING DISPOSAL, INC., a North Carolina corporation, and E.J.E DREDGING SERVICE, LLC, a North Carolina limited liability company (collectively, “Maker”) and DARE COUNTY, a political subdivision organized and existing pursuant to the laws of the State of North Carolina (“Payee”);

W I T N E S S E T H

THAT WHEREAS, Maker and Payee entered into that certain promissory note dated \_\_\_\_\_, 2019 (the “Note”), in the maximum principal amount of Fifteen Million Dollars (\$15,000,000); and

WHEREAS, the Note provides that interest shall not begin accruing until a fully operable Dredge is physically delivered and titled to Maker (the “Interest Commencement Date”); and

WHEREAS, the parties desire to establish the Interest Commencement Date, and the expiration date of the initial term of the Note as set forth below;

NOW, THEREFORE, in consideration of the mutual and reciprocal promises herein contained, and other good and valuable consideration, the receipt and sufficiency of which are hereby acknowledged, Maker and Payee hereby agree that the Note be, and the same is hereby modified in the following particulars:

1. For all purposes under the Note, the Interest Commencement Date shall be \_\_\_\_\_, 201\_\_.
3. The Final day of the Initial Term of the Note shall be \_\_\_\_\_, 20\_\_.
4. Except as modified and amended by this Interest Commencement Date Agreement, the Note shall remain in full force and effect.

IN WITNESS WHEREOF, Maker and Payee have caused this Interest Commencement Agreement to be duly executed, as of the day and year first above written.

E.J.E RECYCLING DISPOSAL, INC.

By: \_\_\_\_\_

Name: \_\_\_\_\_

Title: \_\_\_\_\_

E.J.E DREDGING SERVICE, LLC

By: \_\_\_\_\_

Name: \_\_\_\_\_

Title: \_\_\_\_\_

DARE COUNTY

By: \_\_\_\_\_

Name: \_\_\_\_\_

Title: \_\_\_\_\_

**FIRST PREFERRED SHIP MORTGAGE**

**Vessel:**  
**(Official Number \_\_\_\_\_ )**

**Date:**

**Amount:**

THIS FIRST PREFERRED SHIP MORTGAGE, made by:

**EJE DREDGING SERVICE, LLC**, a North Carolina limited liability company, (“Owner”), , whose address is \_\_\_\_\_, the sole owner of the whole of the vessel \_\_\_\_\_ (Official Number \_\_\_\_\_), to

**DARE COUNTY**, a political subdivision organized and existing pursuant to the laws of the State of North Carolina, whose address is: \_\_\_\_\_, and its successors and assigns (“Mortgagee”), as follows.

**WITNESSETH:**

THAT WHEREAS, Owner is in the business of maintenance and navigation dredging, beach nourishment, habitat creation, and environmental restoration; and

WHEREAS, Owner is an affiliate of and wholly owned by E.J.E. Recycling Disposal, Inc., a North Carolina corporation authorized to do business in North Carolina (“Affiliate”), which is also in the business of maintenance and navigation dredging, beach nourishment, habitat creation, and environmental restoration; and

WHEREAS, Owner and Affiliate both benefit from being able to conduct business with each other; and

WHEREAS, Affiliate’s loans from Mortgagee will benefit Owner’s business; and

WHEREAS, Affiliate and Owner are justly indebted and obligated to Mortgagee as a result a term loan and a work plan agreement as evidenced by, among other things, the following:

- (a) A Promissory Note dated \_\_\_\_\_ from Owner and Affiliate in the principal amount of \_\_\_\_\_ payable to the order of Mortgagee; and
- (b) A Dredge Work Plan and Forgivable Loan Agreement dated \_\_\_\_\_ between Owner and Affiliate and Mortgagee;
- (c) All Exhibits to the Note and Work Plan

(as in effect from time to time, and as modified, extended, replaced, or restated, the foregoing documents in (a), (b) and (c) are collectively the “Notes”) and further may be evidenced by certain additional loan documents executed contemporaneously herewith (the “Loan Documents”)—all capitalized terms used in this Mortgage, but not otherwise defined herein, having the meanings ascribed to them in the Loan Documents; and

WHEREAS, in consideration of the Notes and Loan Documents, Owner has agreed to secure the Notes and Loan Documents with a preferred ship mortgage on the Vessel (as defined below);

NOW, THEREFORE, in consideration of the foregoing recitals, the loans and obligations made pursuant to the Notes and Loan Documents, the promises made herein, and other valuable consideration, the receipt and sufficiency of which are hereby acknowledged, Owner hereby mortgages and conveys the whole of the following vessel (the “Vessel”) to the Mortgagee, its successors and assigns to secure payment of all sums owed by Affiliate under the Notes (including without limitation interest, late charges, attorney’s fees, and other sums) and performance of Owner and Affiliate’s obligations under the Notes and the Loan Documents, as they may be amended, modified, supplemented, restated, and/or replaced.

<b>Vessel Name</b>	<b>Official Number</b>

The term “Vessel” shall include any and all of the following described items, now or hereafter belonging to the vessel or normally carried thereon, if any, all of which are subject to the security interest and lien of this Mortgage: all dredging equipment, masts, spars, capstans, spare parts, towers, boilers, cables, engines, machinery, bowsprits, sails, rigging, auxiliary boats, anchors, chains, apparel, furniture, tackle, fittings, tools, pumps, pumping equipment, radar, depth sounder, AIS equipment; electronic equipment, radios, other equipment and supplies, and any and all fishing and other appurtenances, accessories and additions, improvements and replacements now or hereafter belonging thereto, whether or not removed therefrom.

Except as may otherwise be stated herein, United States Code Title 46, Chapter 313, as amended, shall govern this Mortgage.

## **I. COVENANTS AND WARRANTIES OF OWNER**

1. Owner and Affiliate covenants, represents, and warrants to Mortgagee that:

1.1. Each is and shall remain a citizen of the United States and Owner is entitled to own and operate the Vessel under its Certificate of Documentation and coastwise and other operational endorsements, which Owner shall maintain in full force and effect; all actions necessary for the execution, delivery and validity of this Mortgage have been taken; Owner is duly organized as a North Carolina corporation and is and shall continue in good standing under the laws of the State of North Carolina and in any other state where Owner does business, and Owner is authorized to execute this Mortgage.

1.2. Owner owns and possesses the Vessel free and clear from all liens, sanctions, and encumbrances. Owner shall warrant and defend title to and possession of the Vessel for the benefit of Mortgagee against all other persons and entities. Owner shall not set up any claim of ownership of the Vessel against Mortgagee.

1.3. Owner shall comply with, and not permit the Vessel to be operated contrary to, the laws, treaties, conventions, rules, regulations or orders of the United States, and any state or jurisdiction where they are operated, nor remove the Vessel from the territorial limits of the United States, nor abandon the Vessel in any foreign port. Owner shall do everything necessary to establish and maintain this Mortgage as a First Preferred Ship Mortgage on the Vessel. Owner shall comply with, and not permit the Vessel to be operated contrary to, any navigation limits and other requirements of the insurance carried on the Vessel.

1.4. Owner (a) agrees to be bound by the provisions of this Mortgage; (b) consents to being joined, if necessary for complete relief to be granted, in any enforcement action on the Notes (or any of them) or Mortgage, or under the Loan Documents, and (c) acknowledges that the Mortgagee is loaning or disbursing funds on the condition that the Notes and Loan Documents are secured by this Mortgage.

1.5. Owner, by executing this Mortgage, by Affiliate receiving money loaned from Mortgagee and executing this Mortgage, by having actual knowledge of Affiliate having executed the Notes and other Loan Documents that the Mortgagee intends to secure the Notes with this Mortgage, and/or by having such knowledge at any time and not promptly notifying the Mortgagee in writing by certified mail that the Owner did or does not consent to this Mortgage, hereby agrees to this Mortgage.

1.6. Owner gives Mortgagee the right, upon the occurrence of an "Event of Default", as defined herein, to arrest and repossess the Vessel wherever it may be found and sell it, and if, after deducting from the proceeds of sale all amounts due Mortgagee under the Notes or other Loan Documents, including but not limited to costs and attorneys' fees incurred in arresting, repossessing, storing, protecting, and selling the Vessel and costs of cleaning, transporting, commissions, repairs, reconditioning, new equipment, storage and dockage fees, and all other costs determined by Mortgagee, in its reasonable discretion, to be in its interests to incur, there is a deficiency, in that the proceeds are insufficient to pay Mortgagee all amounts due to it, Mortgagee may sue Owner for the deficiency in any appropriate state or federal court and in the event of suit, recover any costs and attorneys' fees it incurs in such suit and any costs and attorneys' fees previously mentioned in this paragraph.

1.7. Neither Owner, nor Owner's agent or masters of the Vessel, has or shall have any right, power or authority to create, incur or permit to be placed or imposed on the Vessel any lien other than to Mortgagee or for crew's wages or salvage, without Mortgagee's written consent. Owner shall keep prominently posted on the Vessel, a U. S. Coast Guard certified copy of this Mortgage and a notice that the Vessel is subject to a Mortgage in favor of Mortgagee, that no liens may be placed upon the Vessel without the written permission of Mortgagee, and that the Vessel may not be leased to or chartered by any third party other than Affiliate without Mortgagee's prior written

consent, which consent shall not be unreasonably withheld. Owner will also promptly cause a copy of this Mortgage, certified by the U. S. Coast Guard, to be kept on the Vessel and in the office of Owner from which the Vessel is chartered, available for inspection, and will exhibit the same and with the Vessel's papers upon demand to any person having business with the Vessel. Owner will take such other appropriate steps from time to time as will give notice to the world that Owner's right, title and interest in and to the Vessel is subject to this Mortgage, and that, except for this Mortgage and the other Loan Documents, Owner has no right, power or authority to suffer or permit any liens or claims against the Vessel.

1.8. Owner shall pay when due all taxes, assessments, license fees, governmental charges, fines and penalties imposed upon the Vessel and promptly discharge any and all liens and claims upon the Vessel. Owner shall at all times keep the Vessel in good repair, appearance and working order. If on the date of this Mortgage the Vessel has an ABS or other Classification Certificate and/or Load Line Certificate, Owner shall take all action necessary to maintain the Vessel's current Classification, and Owner shall maintain the Vessel according to its standards, including all repairs, replacements, and dry-dockings. Owner shall take all action necessary to maintain the Vessel's Load Line Certificate, and Owner shall maintain the Vessel according to its standards, including all repairs, replacements, and dry-dockings. Owner will provide the Mortgagee with copies of the renewals of the Classification and the Load Line Certificate.

1.9. If the Vessel shall be libeled, arrested, attached, detained or repossessed by any third party, seized or levied upon or taken into custody under process or under color of liens and claims upon the Vessel, Owner shall immediately notify Mortgagee, confirmed in writing, by letter sent by certified mail and discharge or release, and use commercially reasonable efforts to recover the Vessel within twenty (20) days.

1.10. Owner shall at all reasonable times afford Mortgagee complete opportunity to inspect the Vessel and immediately upon request by Mortgagee, Owner shall state the exact location of the Vessel. Owner shall promptly, and in any event when due, pay all charges for repairs or other services to the Vessel, goods, supplies, wages, fuel, dockage, storage fees, or any other necessities, not disputed, within thirty (30) days to the creditor, with immediate written notice of any such disputed amount sent to Mortgagee. Owner shall promptly inform Mortgagee in writing whenever the total of undisputed charges for the above items not paid within thirty (30) days after the due date exceeds Five Thousand and 00/100 Dollars (\$5,000.00). Owner shall also notify Mortgagee promptly of any collision, allision, or other accident in which the Vessel is involved, or of damage to the Vessel that requires repair or which may affect its value.

1.11. Owner shall not, without the prior written consent of Mortgagee, sell, transfer, or mortgage the Vessel, or any interest in the Vessel, or merge or consolidate with any other person, firm or corporation, or dissolve.

1.12. From time to time, Owner shall execute and deliver such other instruments and assurances as Mortgagee may require to perfect or continue this Mortgage and to enforce the terms of this Mortgage, the Notes, or other Loan Documents, for operation of the Vessel, or sale of the Vessel by Mortgagee upon the occurrence of an "Event of Default" as defined below.

## II. INSURANCE

2.1 Owner shall, at its expense, keep the Vessel fully insured under a marine insurance policy or policies providing (1) hull and machinery coverage in an amount not less than the full market value of the Vessel; (2) protection and indemnity coverage in the standard form and amounts acceptable to Mortgagee; (3) collision liability coverage; (4) Jones Act, workers compensation and employers' liability coverage if not included in the Protection and Indemnity coverage; (5) Oil Pollution Act liability coverage in an amount not less than One Million Dollars (\$1,000,000.00), (6) CERCLA environmental/pollution liability coverage in an amount not less than Five Million and 00/100 Dollars (\$5,000,000.00), and (7) such further risks as may be commercially reasonable or reasonably specified by Mortgagee from time to time.

2.2 The hull and machinery policy shall provide that losses payable under the policy shall be paid to Mortgagee, its successors and assigns, and shall include a Breach of Warranty endorsement in favor of Mortgagee, protecting Mortgagee's interest in an amount not less than the full market value of the Vessel, which interest shall not be impaired or invalidated by any breach of a warranty or condition under the policy, other than a change in title or ownership of the Vessel.

2.3 The policies shall include all additional endorsements or coverages reasonably specified by Mortgagee. All such policies shall be taken in Owner's name, shall identify Mortgagee as a mortgagee and additional insured, and shall be in amounts or policy limits subject to Mortgagee's approval unless the amounts or policy limits are otherwise specified herein. Owner shall notify, and Owner and/or Mortgagee shall request all insurers and their agents to agree to notify Mortgagee, at least thirty (30) days in advance, of any cancellation or material change in any insurance coverage. Certified copies of policies and binders shall be delivered to Mortgagee with satisfactory evidence that all premiums and charges have been paid. Owner shall maintain such insurance unimpaired by any act, breach of warranty or otherwise, during the life of this Mortgage. Mortgagee may at any time request proof from the Owner that the insurance is in force. Failure by Owner to furnish proof within seven (7) days of receiving a request from Mortgagee shall constitute an "Event of Default" as defined below, and, in addition to any other rights or remedies, Mortgagee shall have the option, but shall not be required, to procure such insurance at Owner's sole cost and expense, to be paid by Owner upon demand by Mortgagee.

## III. DEFAULT

3.1. Any one or more of the following events shall be an "Event of Default":

- (a) **Payment Defaults.** If any payment due on the Notes or under the other Loan Documents is not made when due.
- (b) **Other Defaults.** Owner's or Affiliate's failure to comply with or to perform any term, obligation, covenant or condition in this Mortgage, or any other agreement between the Owner and Mortgagee. Affiliate's failure to comply with or to perform any term, obligation, covenant or condition in the Notes, other Loan Documents, or any other agreement between the Affiliate and Mortgagee.



- (c) **Insolvency.** The dissolution, merger, consolidation or termination of Owner's or Affiliate's existence as a going business, Owner's or Affiliate's insolvency or inability to pay debts as they mature, the appointment of a receiver for Owner's or Affiliate's property, any assignment by Owner or Affiliate for the benefit of creditors, or the commencement of any processing under any bankruptcy or insolvency laws by or against Owner or Affiliate (except as creditor of a third party).
- (d) **Creditor or Forfeiture Proceedings.** The entry of a judgment against Owner or Affiliate, or the commencement of foreclosure or forfeiture proceeding, repossession, or any other act by any creditor of Owner or Affiliate, or by any governmental agency, against the Vessel or any collateral securing the indebtedness, including garnishment of any of Owner's or Affiliate's deposit accounts with Mortgagee; provided, however, the foregoing shall not apply to garnishment against third-parties from Owner's or Affiliate operating account.
- (e) **Breach of Warranties.** The breach of any of Owner's covenants, representations or warranties in this Mortgage or in the in the Notes, or other Loan Documents. The breach of any of Affiliate's covenants, representations or warranties in the Notes, or other Loan Documents.
- (f) **Deterioration of Vessel.** Any deterioration or impairment of the Vessel or any depreciation in the value of the Vessel, which causes the Vessel, in the reasonable judgment of Mortgagee, to become unsatisfactory as to value. Mortgagee may from time to time require that the Vessel be surveyed and appraised, and Owner shall cooperate with Mortgagee's surveyor to permit access to, and inspection of, the Vessel. Each survey and appraisal shall be performed at Owner's sole cost and expense; provided, however, Owner shall not be obligated to pay the cost of surveys or appraisals performed more frequently than once every two (2) years.
- (g) **Fraud or Misrepresentation.** Owner or Affiliate commits fraud or makes a material misrepresentation, or omits to disclose facts necessary to keep any representation made from being misleading, at any time in connection with this Mortgage or the Notes.

Notwithstanding the foregoing, if Owner has not been given more than one (1) notice of the same breach or default within the preceding twelve (12) months, the breach or default may be cured (and no Event of Default shall be deemed to have occurred) if Owner, after written notice from the Mortgagee to Owner demanding cure of such default: (i) cures the default within seven (7) days if it is a payment default and (ii) thirty (30) days if it is a default other than a payment default. The Owner's right to cure, however, shall not apply to (a) default of Owner's obligation to insure the Vessel, (b) defaults which are not susceptible to cure (such as without limitation a report, certificate or financial information statement or incorrect representation or warranty which is false or misleading), (c) default in payment at maturity, (d) appointment of a receiver or other custodian of the Owner's or guarantor's assets, (e) sale or other transfer of the Vessel, (f) a lien on the Vessel other than allowed by the Loan Documents, (g) financial reporting requirements, or (f) defaults for

which cure periods are already stated. Further, if during any cure period the Mortgagee's collateral or lien priority is threatened, the Mortgagee may take reasonable actions at the Owner's expense to protect the Mortgagee's interests.

3.2. If an Event of Default occurs, in addition to any other rights and remedies provided to Mortgagee under applicable law, the Notes or other Loan Documents, Mortgagee may:

- (a) Accelerate and declare immediately due and payable all the unpaid principal, accrued interest, any late charges, and, as permitted by applicable law, any other amounts due under the Notes, the other Loan Documents, or this Mortgage, after which these amounts shall earn interest at the default rate of interest provided in the Notes. Any arrest and repossession of the Vessel by Mortgagee, or suit on the Mortgage, Notes, or other Loan Documents or other action taken by Mortgagee authorized in (b) through (e) below, shall also constitute such a declaration by Mortgagee, even if no such declaration, or demand for payment, has been made previously to Owner.
- (b) Bring suit in federal or state court against the Vessel and/or Owner, and in such action, recover all costs of suit, including reasonable attorneys' fees. Owner consents to the appointment of a substitute custodian selected by Mortgagee. Mortgagee may also obtain appointment of a receiver for the Vessel. Mortgagee may at any time dismiss any action and take possession of the Vessel and exercise all powers given under this Mortgage, including those given in section (d) below.
- (c) Recover judgment for any amounts due and collect it out of the property of Owner.
- (d) In addition to all other remedies provided, repossess the Vessel without legal process, or use state legal process to do so, at any time, wherever the Vessel may be, and, without being responsible for loss or damage, hold and in Mortgagee's or Owner's name, sell, lease, charter, operate, transfer, or otherwise use the Vessel for the time and upon the terms as Mortgagee deems advisable. Mortgagee may sell the Vessel free from any claim by Owner, and the sale may include all appurtenances on board the Vessel at the time it or they are retaken by Mortgagee or normally on board but removed by Owner; provided, however, Mortgagee shall not have any rights in or to any cargo on board the Vessel. If Mortgagee elects, repossession and sale may take place under state law and this Mortgage shall not be used to prevent election to use state law remedies. To the extent permitted by law, the sale may be public or private, with at least twenty-one (21) days prior written notice to Owner, without having the Vessel present, and Mortgagee may be the purchaser and for payment may pay all or part of the indebtedness secured by this Mortgage. Owner agrees that it will cooperate fully to permit peaceful repossession, and will disclose promptly the exact location of the Vessel to permit Mortgagee to obtain possession of any or all of them.
- (e) For purposes of dealing with the Vessel following any Event of Default, Mortgagee and its agents are irrevocably appointed the true and lawful attorneys of Owner in

Owner's name and stand for all purposes, including but not limited to selling the Vessel and doing all things (including execution of documents) necessary to the sale and to protect Mortgagee's interest.

3.3. If an Event of Default occurs, Owner and any other person aboard the Vessel shall immediately leave the Vessel upon the oral or written request of Mortgagee, and shall leave the Vessel in good, clean and neat condition. If the Vessel is arrested or detained by any officer of any Court or by any authority, Owner hereby authorizes Mortgagee, its agents and appointees, to receive or take possession of the Vessel, load and/or discharge cargo, and to defend any action or discharge any lien. All expenses incurred by Mortgagee as a result of such action shall be added to the indebtedness secured by this Mortgage. If the Mortgagee pays any lien or claim, this shall be an Event of Default by Owner, and Mortgagee may immediately enter on and use the Vessel as it sees fit and this shall be regarded as a lawful repossession.

3.4. Each and every power or remedy given to Mortgagee shall be cumulative, and in addition to all powers or remedies now or hereafter existing in admiralty, in equity, at law or by statute, and may be exercised as often as deemed necessary by Mortgagee. No delay or omission by Mortgagee shall impair any right, power or remedy, and no waiver of any default shall waive any other default.

3.5. Mortgagee may apply the net proceeds of any judicial or other sale, and any charter, management, operation or other use of the Vessel by Mortgagee, of any claim for damages, of any judgment, and of any insurance proceeds received by Mortgagee (except to the extent paid to Owner or applied in payment or repairs or otherwise for Owner's benefit) (hereinafter "Proceeds") as follows:

FIRST: to the payment of all reasonable attorneys' fees, court costs, and any other expenses, losses, charges or damages incurred or advances made by Mortgagee in the protection of its rights or caused by Owner's default with interest at the default rate of interest in effect hereunder, and to provide adequate indemnity against any liens claiming priority over this Mortgage.

SECOND: to the payment of all interest (including any interest accruing at the default rate of interest), to date of payment, on the Notes and any or all sums secured by this Mortgage, and to any balances of such proceeds to the payment next of all matured installments of principal and then of all unmatured installments or principal in the inverse order of their maturity.

If, after deducting from the Proceeds the amounts above, there is a deficiency, Mortgagee may collect the deficiency from the Owner and, in doing so, may apply, without prior notice, any deposits or other assets of the Owner to payment of the deficiency.

3.6. All advances and expenditures which Mortgagee in its reasonable discretion may make for repairs, insurance, payment of liens or other claims, defense of suits, or for any other purpose related to this Mortgage, the Notes or under the Loan Documents, and all damages sustained by Mortgagee because of a default, shall be paid by Owner on demand or, at Mortgagee's option, shall be added to the unpaid balance of the Notes and paid by Owner. Mortgagee shall not be

obligated to make any such advances or expenditures; nor shall their making relieve Owner of any obligation or default related to the advances or expenditure.

#### IV. POSSESSION UNTIL DEFAULT

Until an Event of Default occurs, Owner shall be permitted to retain actual possession and use of the Vessel.

#### V. MISCELLANEOUS PROVISIONS

5.1. Time is material and of the essence in this Agreement. Mortgagee waives no rights by accepting late or partial payments, or by delaying enforcing any of its rights hereunder. No changes, additions, or deletions in any terms shall be valid unless signed by an authorized officer of Mortgagee.

5.2. Any provisions deemed invalid under any law, rule or regulation of any governmental agency shall not affect any other provision hereof.

5.3. This Mortgage is additional security given to Mortgagee as incentive to advance funds under the Notes and pursuant to the terms of the other Loan Documents.

5.4. This Mortgage shall be governed according to the laws of the United States and the State of North Carolina, without reference to any law regarding choice of law.

5.5. Nothing shall be construed to impose any obligation on Mortgagee to extend, or continue to extend, any credit at any future time.

5.6. To the extent there is a conflict between the terms of this Mortgage and other documents between the parties, the provisions of this Mortgage shall control.

5.7. E.J.E. Recycling Disposal, Inc. joins in the execution of this Mortgage to acknowledge its authorization and approval of the same, authorize and consent to the execution by Owner, and to reaffirm its obligations, liabilities and duties under the terms of the Notes, Loan Documents and other documents executed between the parties.

As of the date first written above, Owner has caused this Mortgage to be executed in its name by a person authorized to do so.

**EJE DREDGING SERVICE, LLC**, a North Carolina limited liability company

By: \_\_\_\_\_  
\_\_\_\_\_, President

STAMP

STATE OF NORTH CAROLINA  
CITY/COUNTY OF \_\_\_\_\_

On this \_\_\_\_ day of \_\_\_\_\_, 20\_\_, before me, a notary in and for the State and City or County aforesaid, personally appeared \_\_\_\_\_, President of \_\_\_\_\_, who is personally known to me or who has produced \_\_\_\_\_ as identification, and executed foregoing instrument, on behalf of said corporation.

\_\_\_\_\_  
Notary Public

Notary Registration Number: \_\_\_\_\_  
My Commission Expires: \_\_\_\_\_

By: \_\_\_\_\_  
\_\_\_\_\_, Executive Vice President

STAMP

STATE OF NORTH CAROLINA  
CITY/COUNTY OF \_\_\_\_\_

On this \_\_\_\_ day of \_\_\_\_\_, 20\_\_, before me, a notary in and for the State and City or County aforesaid, personally appeared \_\_\_\_\_, Executive Vice President of \_\_\_\_\_, who is personally known to me or who has produced \_\_\_\_\_ as identification, and executed foregoing instrument, on behalf of said corporation.

\_\_\_\_\_  
Notary Public

Notary Registration Number: \_\_\_\_\_  
My Commission Expires: \_\_\_\_\_

**E.J.E. RECYCLING DISPOSAL, INC., a North Carolina Corporation**

By: \_\_\_\_\_  
\_\_\_\_\_, President

STAMP

STATE OF NORTH CAROLINA  
CITY/COUNTY OF \_\_\_\_\_

On this \_\_\_\_ day of \_\_\_\_\_, 20\_\_, before me, a notary in and for the State and City or County aforesaid, personally appeared \_\_\_\_\_, President of \_\_\_\_\_, who is personally known to me or who has produced \_\_\_\_\_ as identification, and executed foregoing instrument, on behalf of said corporation.

\_\_\_\_\_  
Notary Public

Notary Registration Number: \_\_\_\_\_  
My Commission Expires: \_\_\_\_\_

By: \_\_\_\_\_  
\_\_\_\_\_, Executive Vice President

## EXHIBIT C

### CONDITIONAL ASSIGNMENT

In addition to, and not by way of limitation of, the Preferred Ship Mortgage provided in Article I of the Dredge Work Plan And Forgivable Loan Agreement (Loan Agreement), EJE grants, assigns, transfers, conveys and sets over to the County, for the benefit of the County, EJE's entire right, title and interest in and to the Architect/Engineer's Agreement, the design documents for the shallow draft dredge created pursuant to the Architect/Engineer's Agreement, and the Contract between the dredge builder and EJE for the construction of the dredge in accordance with the design documents created pursuant to the Architect/Engineer's Agreement (collectively, "Collateral"); provided that such grant, assignment, transfer and conveyance shall be and become of force and effect only (1) upon or after the occurrence and during the continuance of an Event of Default and (2) either (a) upon the written demand of the County at any time during such continuance or (b) immediately and automatically (without notice or action of any kind by the County) upon an Event of Default for which acceleration of the loan is automatic under the Loan Agreement or upon the sale or other disposition of or foreclosure upon the Collateral pursuant to the terms of the Loan Agreement or the Promissory Note and applicable law (including the transfer or other disposition of the Collateral by EJE to the County in lieu of foreclosure).



*Consent Agenda*

**Description**

1. Approval of Minutes (04.15.19 & 04.17.19 Budget Workshop)
2. Water Line Relocation Agreement - NCDOT Hwy 12 Rodanthe Long-Term Improvements
3. Private Land Burning Agreement between Dare County and U.S. Fish and Wildlife Service
4. Town of Manteo Request - Delegate Approval of Pyrotechnics Permits
5. NCDOT Utility Relocation Agreement - Skyco Road & Toler Road
6. Social Services Division - 14-month Contract with Information, Inc.
7. Public Health Division - Contract with Outer Banks Womens Care
8. Register of Deeds - Software License and Support Agreement
9. Assistant Medical Director Agreement
10. Audit Contract for Fiscal Year 2019
11. Tax Collector's Report

**Board Action Requested**

Approval

**Item Presenter**

County Manager, Robert Outten





*Approval of Minutes*

**Description**

The Board of Commissioners will review and approve their previous Minutes, which follow this page.

**Board Action Requested**

Approve Previous Minutes

**Item Presenter**

County Manager, Robert Outten



# County of Dare

P.O. Box 1000 | Manteo, NC 27954

---

## MINUTES

### DARE COUNTY BOARD OF COMMISSIONERS MEETING

Dare County Administration Building, Manteo, NC

**5:00 p.m., April 15, 2019**

Commissioners present: Chairman Robert Woodard, Vice Chairman Wally Overman  
Rob Ross, Steve House, Jim Tobin, Danny Couch, Ervin Bateman

Commissioners absent: None

Others present: County Manager/Attorney, Robert Outten  
Deputy County Manager/Finance Director, David Clawson  
Public Information Officer, Dorothy Hester  
Clerk to the Board, Gary Lee Gross

A full and complete account of the entire Board of Commissioners meeting is archived on a video that is available for viewing on the Dare County website [www.darenc.com](http://www.darenc.com).

At 5:04 p.m. Chairman Woodard called to order the regularly scheduled meeting with appropriate prior public notice having been given. He invited Rev. David Morris from the Unitarian Universalist Congregation of the Outer Banks to share a prayer, and then he led the Pledge of Allegiance to the flag. Note - some items were handled out of sequential order.

#### **ITEM 1 – OPENING REMARKS – CHAIRMAN’S UPDATE**

Following is a brief outline of the items mentioned by Chairman Woodard during his opening remarks, which can be viewed in their entirety in a video on the Dare County website –

- Gave a report on activities at the College of the Albemarle (COA) by mentioning upgrades that have been made to the Library at the Elizabeth City campus. Chairman Woodard noted that the Board of Commissioners has taken action to build a new facility for the Dare County campus. He reported that funding for the project was recently approved and gave an update on the project’s Request for Qualifications (RFQ) process. He voiced excitement about the potential and opportunities for COA Dare.
- Chairman Woodard advised that the Search Committee tasked with looking for a new COA President is looking for a replacement for Dr. Wynegar who is leaving.
- Reported on the ribbon cutting ceremony for the Marc Basnight Bridge over Oregon Inlet.
- Commended Vice Chairman Overman and the Saving Lives Task Force for the latest Town Hall event that featured an informative presentation by Dr. Murphy
- Asked the community to keep the owners of the Christmas Mouse in their thoughts and prayers in the wake of the devastating fire they recently suffered.
- Congratulated Tiger Woods on his victory at the Masters Golf Tournament.

## **ITEM 2 – PUBLIC COMMENTS**

At 5:14 p.m. the Manager outlined the procedure for making public comments in Manteo and via the video link to Buxton. No one responded to the invitation to address the Board. The County Manager closed Public Comments at 5:14 p.m.

## **ITEM 3 – 2019 GOVERNOR’S VOLUNTEER SERVICE AWARDS**

Lorelei Costa, Executive Director of the Outer Banks Community Foundation, presented the 2019 recipients of the Governor’s Volunteer Service Awards. Among those honored were Laura Davis, Lynda Hester, Mary Ellen Holland, Jonna Lewis, Dennis Pohl, Kathleen Morgan, Juliane Kelly, Marion & Blair Siefferman, George Viverette & Sheryl Tillett, and Wendy Sisler. It was noted that Ms. Sisler will be receiving the Governor’s Medallion Award at an upcoming ceremony in Raleigh.

## **ITEM 4 – DARE SOIL & WATER CONSERVATION DISTRICT REPORT**

Ann Daisey outlined projects and outreach programs for the Dare Soil & Water District. Her presentation showcased work that has been done on stream debris removal and alligator weed control. Ms. Daisey explained that each dollar invested by the County has returned an average of \$18.65 in value. She noted that the opportunity to be full time staff for Soil & Water will open up more grant opportunities and described the dynamic partnership that exists between local, state, and federal entities.

## **ITEM 5 – MEDCOST MEDICAL INSURANCE FY 2019-2020**

The County Manager reported that the County’s 2019-2020 rates for MedCost medical insurance are remaining the same at a zero percent increase. He said this indicates that the County’s wellness activities are having a positive impact. Mr. Outten advised that the medical insurance component needs Board approval prior to the presentation of the budget.

### **MOTION**

Commissioner House motioned to approve the FY19/20 MedCost medical insurance plans. Commissioner Ross seconded the motion.

VOTE: AYES unanimous

## **ITEM 6 – TIMOTHY JENNETTE – REQUEST TO FILL DITCH**

Planning Director Donna Creef introduced Timothy Jennette who presented a request for permission to fill part of a drainage ditch to access the rear portion of property he owns in Buxton. It was noted that County Code requires Board approval following a Public Hearing in order to block or fill a ditch, creek, or other water course. Mr. Jennette gave the history of the ditch and reported what he was told by a wetlands consultant and the Corps of Engineers. He added that the ditch provides the only access he has to the back portion of his property. Commissioners asked questions about the site and storm water flow in the vicinity of the property. Mr. Jennette requested that the Board schedule a public hearing on the matter and he was advised to prepare as much information as possible in advance of a Public Hearing.

### **MOTION**

Commissioner Tobin motioned to set a public hearing for 5:30 p.m., May 20, 2019. Commissioner Bateman seconded the motion.

VOTE: AYES unanimous

### **ITEM 7 – HOUSING AMENDMENTS – PROGRESS REPORT**

Planning Director Donna Creef gave the Board a progress report on the series of zoning amendments that were adopted in 2018 to facilitate housing opportunities. She provided statistics on permits for the past six months which resulted in two Cluster Home projects being approved for Hatteras Island. Ms. Creef also listed options including expanding cluster homes, expanding accessory dwelling units, developing an overlay district for educational housing, and studying the issue of minimum lot sizes. The Planning Director noted that recreational vehicles, trailers, and tiny homes are not constructed for use as year-round dwellings in our area. Commissioner House urged the Board to do whatever is necessary for educational housing in order to attract students to the area. Guidance was given on ADU's and other items outlined by the Planning Director and by consensus the Board agreed that the matter should be pursued with the Planning Board and solicit public input and then be brought back to the Board of Commissioners.

### **ITEM 8 – HEALTH & HUMAN SERVICES BUILDING – EXPANSION AND RENOVATIONS**

In follow-up to an item discussed at the March 6 Board Retreat, Finance Director David Clawson provided background information about an expansion study of the Health & Human Services (DHHS) buildings in Manteo, which is included in the 2019 CIP and part of 2019 Limited Obligation Bonds. Mr. Clawson explained that Oakley Collier was selected to perform the DHHS study and outlined three options. He asked the Board to give staff direction to issue a request for qualifications (RFQ) for architects for the design of Option #2.

#### **MOTION**

Commissioner Ross motioned to give staff direction to issue a request for qualification for architects for the design of Option #2.

Vice Chairman Overman seconded the motion.

VOTE: AYES unanimous

### **ITEM 9 – CONSENT AGENDA**

The Manager announced the items as they were visually displayed in the meeting room.

#### **MOTION**

Commissioner House motioned to approve the Consent Agenda:

- 1) Approval of Minutes (04.01.19) **(Att. #1)**
- 2) Water Department NCDOT Right of Way Encroachment Agreement

Commissioner Bateman seconded the motion.

VOTE: AYES unanimous

### **ITEM 10 – COMMISSIONERS' BUSINESS & MANAGER'S/ATTORNEY'S BUSINESS**

Commissioners and the County Manager frequently make extensive remarks, which can be viewed in their entirety in a video on the Dare County website. Following is a brief summary outline of the items mentioned by Commissioners during this segment –

#### **Commissioner Tobin**

- Reported on a recent meeting in New Bern on the local dredge project and explained what was said about spoil sites and the impact it would have on Dare County dredging.

- Gave an update on the latest meeting of the Oregon Inlet Task Force where removal of the Bonner Bridge was discussed. He noted that rumors claiming that bridge material must first be cleaned before being discarded are untrue.

#### Commissioner Ross

- Commented on the recent Legislative Fish Fry in Raleigh that was well attended and provided a valuable opportunity to network with legislators on important issues.
- Noted that the Albemarle Commission has a new Finance Director.
- Advised the Board that the Albemarle Commission is taking a serious look at its Revolving Loan Program to determine if the project should be continued. He said it is designed to make small business loans that banks are not inclined to make and noted that it requires a substantial amount of administrative time and effort.
- Reported on today's Audit Committee meeting where the new internal auditor was introduced.
- Encouraged people to vote in the April 30 election for which early voting is now underway.
- Expressed sadness about the devastating fire at the Notre Dame Cathedral in Paris.

#### Commissioner House

- On behalf of the area's commercial fishermen, he thanked everyone who went to the Legislative Fish Fry in Raleigh.
- Commended all the first responders who fought strong winds to battle the recent fire at the Christmas Mouse in Nags Head.
- Presented a historical fact concerning the death of President Abraham Lincoln who died on this day in history from injuries inflicted by John Wilkes Booth.
- The Pet of the Week video was shown and everyone was urged to consider pet adoption.
- Commissioner House presented a resolution opposing House Bill 486 and any change in the definition of commercial fishing. He noted that the Board, on behalf of our working watermen, has steadfastly opposed this each time the Legislature has considered it.

#### **MOTION (Att. #2)**

Commissioner House motioned to adopt the resolution opposing H.B. 486 as presented. Commissioner Tobin seconded the motion.

VOTE: AYES unanimous

#### Vice Chairman Overman

- Congratulated everyone who received a Governor's Volunteer Service Award. He said Dare County is blessed to have such service oriented people in our community.
- Reported on the recent Town Hall Event sponsored by the Saving Lives Task Force where Dr. Greg Murphy gave an outstanding presentation on the opioid crisis.
- Noted that the Recovery Court is now operational and thanked the Board for supporting it.
- Commented on the recent Open House at CSI where 250 toured the educational facility.
- Vice Chairman Overman asked the Board to adopt a resolution supporting the More Powerful NC Campaign regarding the opioid crisis. He noted that many items outlined in the resolution are already being done by Dare County and the Saving Lives Task Force.

#### **MOTION (Att. #3)**

Vice Chairman Overman motioned to adopt a resolution supporting the More Powerful NC Campaign as presented.

Commissioner Bateman seconded the motion.

VOTE: AYES unanimous

### Commissioner Bateman

- Expressed appreciation for the way that Jan Burrows goes above and beyond the call of duty as a trash truck driver and commended the way she helps people.
- Congratulated those who received the Governor's Volunteer Service Awards.
- Commented on the Saving Lives Task Force Town Hall where Dr. Greg Murphy noted that someone dies every 14 minutes due to opioids. He said millions of dollars are being funneled down from the Governor's Office and recommended that the County pursue getting some of these funds.

### Commissioner Couch

- Reported that Fletcher Willey has resigned from the Waterways Commission and commended Mr. Willey for the excellent way he always prepared for each meeting.
- He said the Coordinator for the Recovery Court is excellent. He voiced concern about all the pressures that are being put on our young people and the need to support that effort.
- Thanked the Board of Commissioners for its support of the Legislative Fish Fry in Raleigh and spoke appreciatively of the attention that Senator Steinburg and Representative Hanig are giving to Dare County issues.
- Noted that business activity is going well as we go into the spring season.
- Thanked Public Information Officer Dorothy Hester for the campaign regarding trash pickup.
- Commented on the excellent work that has been done on the upcoming budget and said we are in a good position for the upcoming fiscal year.

### Chairman Woodard

- Advised the Board that he would be traveling to Elizabeth City tomorrow with Public Information Officer Dorothy Hester for a College of the Albemarle Board of Trustees meeting to give County's presentation urging students to attend COA.

## **MANAGER'S/ATTORNEY'S BUSINESS**

1. The County Manager presented a Short Term Restricted Fund spending request from the Tourism Board for a total expenditure of \$50,000 for July 4<sup>th</sup> Fireworks. He outlined the portion being allocated to Avon, Kill Devil Hills, Manteo, and Nags Head.

### **MOTION**

Vice Chairman Overman motioned to approve the Restricted Fund spending request. Commissioner Bateman seconded the motion.

VOTE: AYES unanimous

2. Mr. Outten summarized a resolution adopted by the Town of Manteo asking the North Carolina Legislature to support local bills concerning the regulation of navigable waters within the Town's corporate limits. He asked the Board to consider approving a resolution in support of the Town's legislative request

### **MOTION (Att. #4)**

Commissioner House motioned to approve a resolution in support.

Vice Chairman Overman seconded the motion.

VOTE: AYES unanimous

Public Information Officer Dorothy Hester showcased two awards the County has received for excellence in communications outreach to the public. She also informed the Board that Karen Brown, President and CEO of the Outer Banks Chamber of Commerce accepted an award at an industry conference she recently attended for a video segment featured on CurrentTV. Ms. Hester noted that the GIS Department of Information Technology has been working on a community map that will debut soon featuring many important items of public interest. She also displayed a creative video reminding people to remove trash cans from the curbside after pickup.

### **ITEM 11 – CLOSED SESSION**

The County Manager asked for a Closed Session pursuant to the following statutes - - -

- NCGS 143-318.11(a)(3) to consult with an attorney employed or retained by the County in order to preserve the attorney-client privilege including the matter of the opioid lawsuit.
- NCGS 143-318.11(a)(5) to instruct the County staff, or negotiating agents, concerning the position to be taken by or on behalf of the County in negotiating the price and other material terms of a contract, or proposed contract, for the acquisition of real property by purchase, option, exchange, or lease in the matter of the parcel adjoining the Buxton Transfer Station.
- NCGS 143-318.11(a)(6) to review the qualifications, competence, performance, character, fitness, conditions of appointment, or conditions of initial employment of an individual public officer or employee or prospective public officer or employee.
- And to approve the minutes of the last Closed Session.

#### **MOTION**

Vice Chairman Overman motioned to go into Closed Session pursuant to the provisions of the North Carolina General Statutes cited by the County Manager.

Commissioner House seconded the motion.

VOTE: AYES unanimous

At 6:50 p.m., the Commissioners exited the room to meet in Closed Session. They reconvened at 7:09 p.m. and Mr. Outten reported that during the Closed Session the Board had discussion with the County Attorney to preserve the attorney-client privilege, and also discussed a real estate matter and a personnel matter. He added that the Board approved previous Closed Session Minutes and took no action in the Closed Session.

At the conclusion of the meeting, Chairman Woodard asked for a motion to adjourn.

#### **MOTION**

Commissioner House motioned to adjourn the meeting.

Commissioner Bateman seconded the motion.

VOTE: AYES unanimous

At 7:57 p.m., the Board adjourned until 9:00 a.m., Tuesday, May 7, 2019.

Respectfully submitted,

[SEAL]

By: \_\_\_\_\_  
Gary Lee Gross, Clerk to the Board

APPROVED: By: \_\_\_\_\_  
Robert Woodard, Chairman  
Dare County Board of Commissioners

Note: copies of attachments (Att.), ordinances, resolutions, contracts, presentations, and supporting material considered by the Board of Commissioners at this meeting are on file in the office of the Clerk to Board.





# County of Dare

P.O. Box 1000 | Manteo, NC 27954

---

## MINUTES

### DARE COUNTY BOARD OF COMMISSIONERS

#### SPECIAL MEETING

To conduct a workshop on the upcoming fiscal year budget and take such action that may come before the Board of Commissioners

Dare County Administration Building, Room #238, Manteo, NC

**9:00 a.m., April 17, 2019**

Commissioners present: Chairman Robert Woodard, Vice Chairman Wally Overman  
Rob Ross, Steve House, Jim Tobin, Ervin Bateman

Commissioners absent: Danny Couch

Others present: County Manager/Attorney, Robert Outten  
Deputy County Manager/Finance Director, David Clawson  
Assistant Finance Director, Sally DeFosse  
Budget Analyst & Internal Auditor, Ernie Dabiero  
Public Information Officer, Dorothy Hester  
Clerk to the Board, Gary Lee Gross

At 9:00 a.m. Chairman Woodard called to order the Special Meeting with appropriate prior public notice having been given and then led the group in the Pledge of Allegiance to the flag. It was reported that Commissioner Couch was unable to attend due to a schedule conflict.

#### **BUDGET WORKSHOP**

The County Manager thanked the Finance Department for doing a comprehensive job assembling a vast amount of budget information. And he commended Department Heads for carefully monitoring their budget throughout the year. Mr. Outten explained why the County is looking at a one-year budget instead of a two-year cycle due to revenue uncertainty and possible legislation in Raleigh that, if enacted, could change the distribution of sales tax revenue. He informed the Board that the budget maintains the County's existing service levels, funds local schools according to the approved formula, and has no tax increase.

Mr. Outten led the Board in a step-by-step analysis of a seven page summary of all the requested changes for the Fiscal Year 2020 budget. As Commissioners reviewed each item, a departmental representative joined the County Manager and Finance Director in providing background information and answering questions. Also discussed were budgetary needs for

the Board of Education and the status of the County’s Other Funds including the Insurance Fund, Sanitation Fund, Water Fund, and the Capital Improvement Fund.

Throughout the workshop, as each item was discussed, the Board gave guidance to the County Manager and Finance Director. Additionally, the Board agreed by consensus that the Manager should look further into developing a staff policy for storm time and a possible change in the amount of vacation time employees can accrue based on years of service.

Chairman Woodard thanked the County Manager and the Finance Department staff for their hard work on the budget. The Board discussed when the budget should formally be presented and staff was instructed to put it on an upcoming agenda as soon as it is ready.

During the Workshop, recesses were taken - 10:45 a.m. to 11:00 a.m. & 12:11 p.m. to 12:24 p.m.

Before closing the Workshop, Chairman Woodard asked the Board to vote on providing direction to the County Manager.

**MOTION**

Commissioner House motioned to direct the County Manager to move forward on the budget incorporating the guidance that was given to staff during the Budget Workshop.

Vice Chairman Overman seconded the motion.

VOTE: AYES unanimous

At 1:01 p.m., the Board of Commissioners adjourned the Budget Workshop.

Respectfully submitted,

[SEAL]

By: \_\_\_\_\_  
Gary Lee Gross, Clerk to the Board

APPROVED: \_\_\_\_\_  
Robert Woodard, Chairman



*NCDOT Use and Occupancy Agreement Approval  
NC 12 - Rodanthe Breach Long-Term Improvements  
Water Line Relocation Agreement  
(Consent)*

**Description**

The reconfiguration of NC Hwy 12 at the intersection of the new "Jug Handle" bridge landing with NC Hwy 12 will require NCDOT's contractor to relocate Dare County's water main at the new intersection. NCDOT's contractor will complete the construction of the new relocated water lines at no expense to Dare County. The water lines will be installed in accordance with Dare County Water Department's Standard Specifications and NCDOT's revised specifications as shown on the plans included in the agreement. Dare County Water will assume ownership and maintenance responsibilities as outlined in NCDOT's standard right-of-way agreement.

**Board Action Requested**

Approval of Attached Agreement and Chairman's signature.  
(Consent Item)

**Item Presenter**

Ken Flatt



STATE OF NORTH CAROLINA  
DEPARTMENT OF TRANSPORTATION

ROY COOPER  
GOVERNOR

JAMES H. TROGDON, III  
SECRETARY

April 15, 2019

WBS ELEMENT: 32635.2.11 (B-2500B)  
COUNTY: Dare  
DESCRIPTION: NC 12 - Rodanthe Breach Long-Term Improvements  
SUBJECT: Use and Occupancy Agreement – Dare County Water Department

Ken Flatt  
Director  
Dare County Water Department  
600 Mustian Street  
Kill Devil Hills, NC 27948

Dear: Mr. Flatt

The construction of the above-mentioned project will require the relocation and adjustment of certain water lines owned by Dare County Water Department. As discussed with you previously, the design for the relocation work will be handled by our engineers and the construction will be included in the Roadway Contract. This work will be done at the expense of the Department of Transportation in accordance with General Statute 136-27.1.

I am sending for your approval, Special Provisions, and Plans showing proposed water line relocations. In accordance with State and Federal Regulations, it will be necessary for the Dare County Water Department and the Department of Transportation to agree in writing as to the terms of use and occupancy for the water lines to remain within the highway right of way. Accordingly, the following conditions will apply with regards to the water lines:

(1) The water lines will be located and accommodated in a manner that will not impair the planned highway or the construction or maintenance or interfere with the safe operation in accordance with the attached plans which are made apart hereof.

(2) The Dare County Water Department will be responsible for maintenance and service of the water lines to be retained within the Department of Transportation's right of way limits in accordance with the mandate of the statutes and such other laws, rules, and regulations that have been or may be validly enacted or adopted now or hereafter.

(3) That upon satisfactory completion of the water line work, the Dare County Water Department agrees that it shall release the Department of Transportation from any and all claims for damage in connection with relocation made to the water lines, and further, that it shall release the Department of Transportation of any further responsibility for the cost of maintenance to the water lines. This release shall be deemed to be given by the Dare County Water Department upon completion of construction of the project and its acceptance by the Department of Transportation from the Roadway Contractor unless the

*Mailing Address:*  
NC DEPARTMENT OF TRANSPORTATION  
1555 MAIL SERVICE CENTER  
RALEIGH, NC 27699-1555

*Telephone:* (919) 707-6690  
*Fax:* (919) 250-4151  
*Customer Service:* 1-877-368-4968

*Location:*  
1020 BIRCH RIDGE DRIVE  
RALEIGH, NC 27610

*Website:* [www.ncdot.gov](http://www.ncdot.gov)

Dare County Water Department notifies the Department of Transportation in writing to the contrary prior to the Department's acceptance of the project.

(4) The Department's Special Provisions binds the contractor to guarantee materials and workmanship against latent and patent defects arising from faulty materials, faulty workmanship or negligence for a period of twelve months following the date of final acceptance of the work for maintenance and shall replace such defective materials and workmanship without cost to the Department. The highway contractor will not be responsible for damage due to faulty design, normal wear and tear, for negligence on the part of the Department, and/or for use in excess of the design. Where items of material carry a manufacturer's guarantee for any period in excess of twelve months, then the manufacturer's guarantee shall apply for that particular piece of material. Appropriate provisions of the payment and/or performance bonds shall cover this guarantee for the project. Should any failure result from the conditions found in line item (4) the Department would then enter into a Contract with the Project Contractor for reimbursement to be made to the Dare County Water Department for necessary repairs performed by Dare County Water Department and/or its contractor. The Utility Relocation Agreement would be issued by the NCDOT Utilities Unit and the repairs would be coordinated between the Dare County Water Department and the Department's assigned Resident Engineer.

Please indicate your concurrence in these conditions and attached plans by signing in the appropriate space provided below and return for our file no later than May 14th, 2019.

Sincerely,

Carl A. Barclay, PE  
State Utilities Manager

BY: Todd D. Lapham

Todd D. Lapham  
Sr. Utility Coordinator – Design Build Projects

CAB: tdl  
Attachment

Approved and Accepted For:

\_\_\_\_\_  
BY: \_\_\_\_\_  
\_\_\_\_\_ TITLE

N.C.G.S. § 133-32 and Executive Order 24 prohibit the offer to, or acceptance by, any State Employee of any gift from anyone with a contract with the State, or from any person seeking to do business with the State. By execution of any response in this procurement, you attest, for your entire organization and its employees or agents, that you are not aware that any such gift has been offered, accepted, or promised by any employees of your organization.

PROJECT SPECIAL PROVISIONS  
Utility Construction  
Dare County Water and Sewer Relocation  
March 12, 2018

Rummel, Klepper & Kahl, LLP  
900 Ridgefield Drive, Ste. 350  
Raleigh, NC 27609

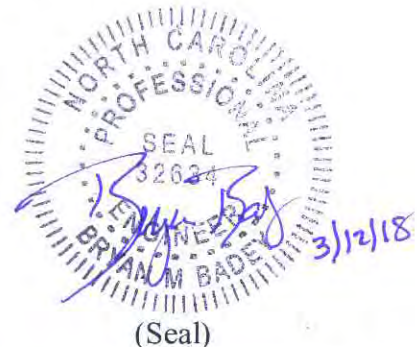

**DOCUMENT NOT CONSIDERED FINAL  
UNLESS ALL SIGNATURES COMPLETED**

The proposed utility construction shall meet the more conservative requirements of the Dare County Water Distribution Standard Specifications latest revision or the NCDOT 2012 "Standard Specifications for Roads and Structures" with amendments noted below.

**Revise the NCDOT 2012 Standard Specifications as follows:**

**Page 10-58, Sub-article 1036-1 General**

add the following sentence:

All materials in contact with potable water shall be in conformance with Section 1417 of the Safe Drinking Water Act.

**Page 15-1, Sub-article 1500-2 Cooperation with the Utility Owner, paragraph 2:**

add the following sentences:

The utility owner is the Dare County Water Department. The contact persons are Ken Flatt, Patrick Irwin or Sammy Midgett and they can be reached by phone at 252-475-5990.

The contractor shall coordinate with Dare County Water Department to provide the required notice to customers prior to any shut down of the waterline.

**Page 15-2, Sub-article 1500-9 Placing Pipelines into Service**

add the following sentence:

Obtain approval from the NCDEQ and Dare County Water Department prior to placing a new water line into service. Use backflow prevention assemblies for temporary connections to isolate new water lines from existing water line.

**Page 15-6, Sub-article 1510-3 (B), Testing and Sterilization**

change the allowable leakage formula to:

$$W = LD\sqrt{P} \div 148,000$$



**Page 15-6, Sub-article 1510-3 (B), Testing and Sterilization, sixth paragraph:**

Replace the paragraph with the following:

Sterilize water lines in accordance with Section 1003 of The Rules Governing Public Water supply and AWWA C651 Section 4.4.3, the Continuous Feed Method. Provide a chlorine solution with between 50 parts per million and 100 parts per million in the initial feed. If the chlorine level drops below 10 parts per million during a 24 hour period, then flush, refill with fresh chlorine solution, and repeat for 24 hours. Provide certified bacteriological and contaminant test results from a state-approved or state-certified laboratory. Operate all valves and controls to assure thorough sterilization.

**Page 15-6, Sub-article 1510-3 (B), Testing and Sterilization, seventh paragraph:**

delete the words “may be performed concurrently or consecutively.”  
and replace with “shall be performed consecutively.”

**Page 15-7, sub-article 1515-2 Materials,**

replace paragraph beginning “Double check valves...” with the following:

Double Check valves (DCV) and Reduced Pressure Zone principal (RPZ) backflow prevention assemblies shall be listed on the University of Southern California Foundation for Cross-Connection Control and Hydraulic Research list of approved backflow devices.

**Page 15-7, Article 1510-4 MEASUREMENT AND PAYMENT,** add the following paragraph after line 7:

The quantity of *Ductile Iron Water Pipe Fittings* will be measured and paid per pound based on the published weights for ductile iron fittings, exclusive of the weights of any accessories, as listed in the “DI Fittings Weight Chart” located at the NCDOT Utilities web site. If the Contractor elects to use compact ductile iron water pipe fittings, measurement will be based on the weight of standard size ductile iron water pipe fittings. Any fitting not listed will be measured based on the published weights for ductile iron fittings listed in ANSI/AWWA C-110/A21.10. This is limited to pressure pipe 4 inches or larger.

**Page 15-7, Article 1510-4 MEASUREMENT AND PAYMENT,** add the following pay item:

<b>Pay Item</b>	<b>Pay Unit</b>
Ductile Iron Water Pipe Fittings	Pound

**Page 15-9, Article 1515-4 MEASUREMENT AND PAYMENT,** line 28, delete “fittings”.  
{this applies to both water AND sewer DI pipe fittings, do not omit unless there is gravity sewer only}

**Page 15-11, Sub-article 1520-3(A)(2) Testing, line 5,**

replace the second paragraph with the following:

Test all 24" and smaller gravity sewer lines for leakage using infiltration, exfiltration, or air test. Perform visual inspection using cameras on gravity sewer mains and services. Perform line and grade testing and deflection testing on all gravity sewer lines.

**Page 15-13, Article 1520-4 MEASUREMENT AND PAYMENT**, add the following paragraph after line 2:

The quantity of *Ductile Iron Sewer Pipe Fittings* will be measured and paid per pound based on the published weights for ductile iron fittings, exclusive of the weights of any accessories, as listed in the “DI Fittings Weight Chart” located at the NCDOT Utilities web site. If the Contractor elects to use compact ductile iron sewer pipe fittings, measurement will be based on the weight of standard size ductile iron sewer pipe fittings. Any fitting not listed will be measured based on the published weights for ductile iron fittings listed in ANSI/AWWA C-110/A21.10. This is limited to pressure pipe 4 inches or larger.

**Page 15-13, Article 1510-4 MEASUREMENT AND PAYMENT**, add the following pay item:

<b>Pay Item</b>	<b>Pay Unit</b>
Ductile Iron Sewer Pipe Fittings	Pound



09\_08/2018

T.I.P. NO.	SHEET NO.
B-2500B	UC-1

**TIP PROJECT: B-2500B**

**CONTRACT: C203474**

STATE OF NORTH CAROLINA  
DIVISION OF HIGHWAYS

**UTILITY CONSTRUCTION PLANS  
DARE COUNTY**

**LOCATION: NC 12 - RODANTHE BEACH LONG TERM  
IMPROVEMENTS (PHASE IIB)**

**TYPE OF WORK: WATER RELOCATION**

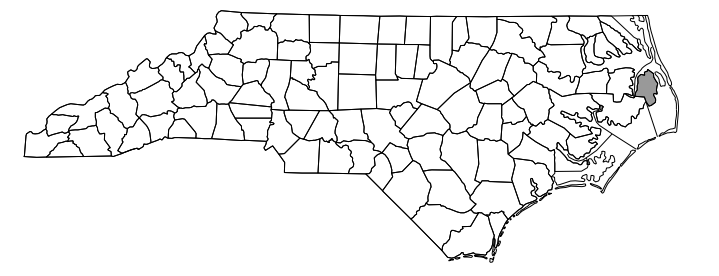
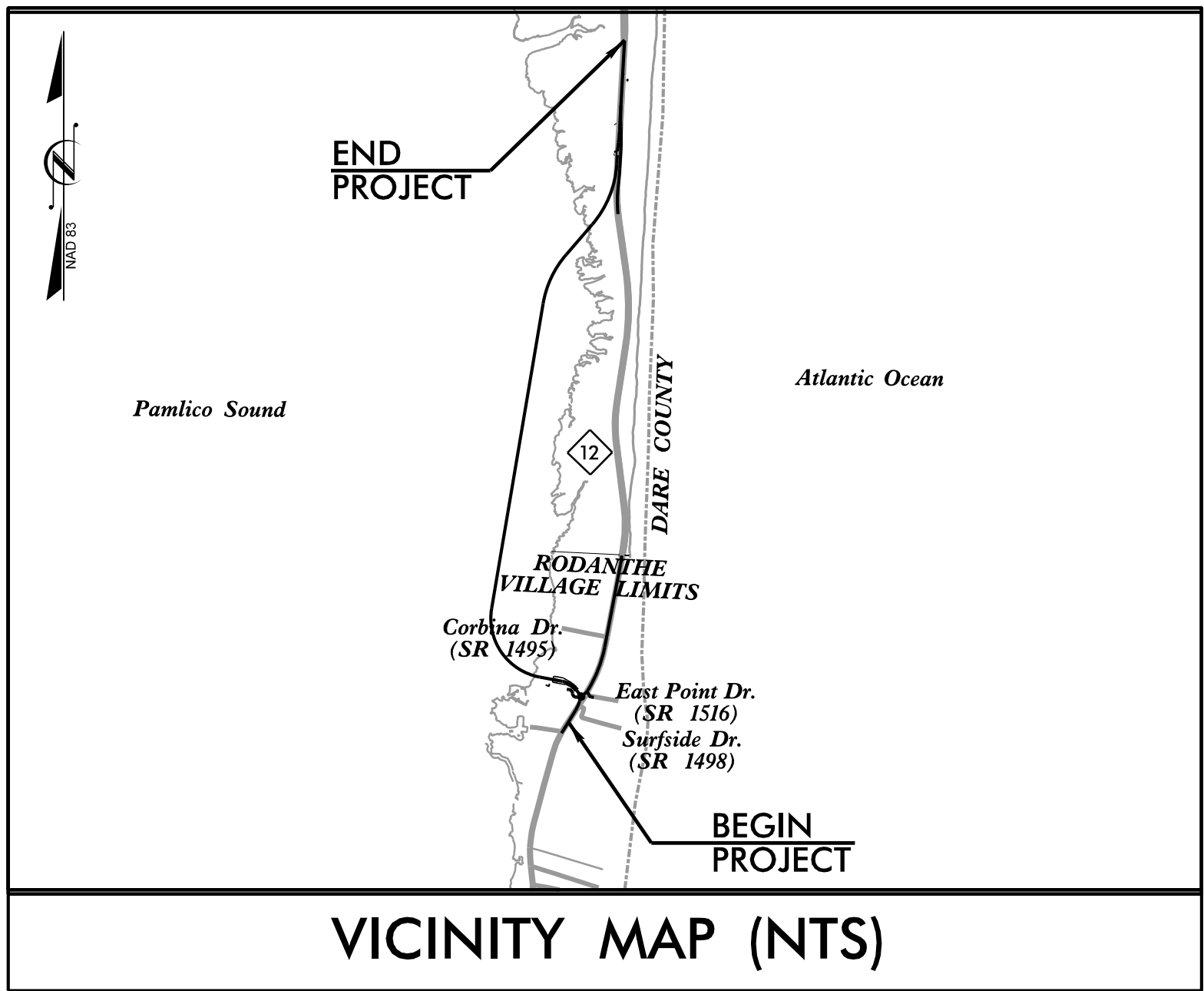

SUBMITTAL S-051  
DARE COUNTY  
RFC UC PLANS  
DATE: 6-08-2018

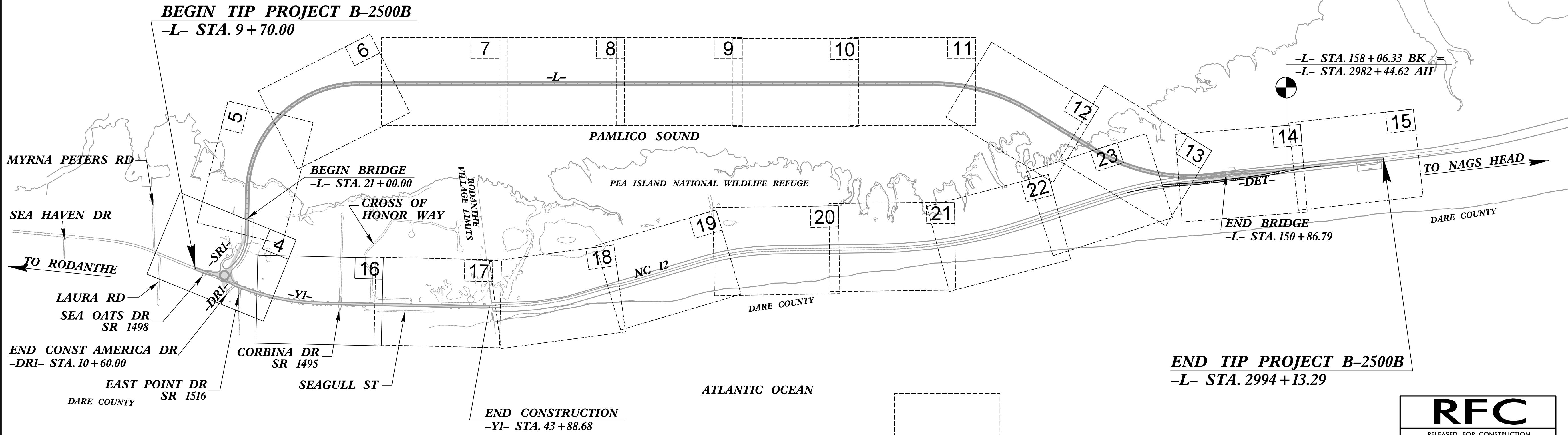

THIS IS A PARTIAL CONTROLLED-ACCESS PROJECT WITH ACCESS BEING LIMITED TO POINTS AS SHOWN ON PLANS.

INDICATES OMITTED SHEETS WITH  
NO WATER OR SEWER CONFLICTS

**RFC**  
RELEASED FOR CONSTRUCTION  
DOCUMENT NOT CONSIDERED FINAL  
UNTIL ALL SIGNATURES ARE COMPLETED

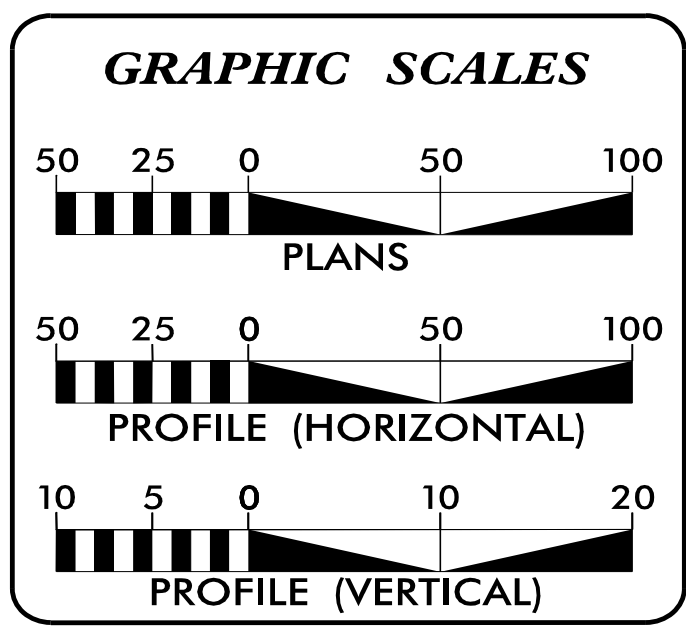

SHEET NO.:	DESCRIPTION:
UC-1	TITLE SHEET
UC-2	UTILITY SYMBOLOGY
UC-3	NOTES
UC-3A	DETAILS
UC-4, 16	UTILITY CONSTRUCTION SHEETS
UC-5	PROFILE SHEETS

**WATER AND SEWER OWNERS ON PROJECT**

(A) WATER - DARE COUNTY

PREPARED IN THE OFFICE OF  
**PLANS PREPARED BY:**  
**RK&K**  
RUMMEL, KLEPPER & KAHL, LLP  
900 RIDGEFIELD DRIVE, SUITE 350  
RALEIGH, NORTH CAROLINA 27609  
NC LICENSE NO. F-0112

FOR NORTH CAROLINA  
DEPARTMENT OF TRANSPORTATION

HOWARD WOODALL P.E. MANAGER UTILITY DESIGN  
BRYAN BADEY P.E. PROJECT MANAGER  
MARIKO PYATT ASSOCIATE ENGINEER

SEAL

DocuSigned by:  
Bryan Badey 6/8/2018

DIVISION OF HIGHWAYS  
UTILITIES UNIT  
1555 MAIL SERVICES CENTER  
RALEIGH, NC 27699-1555  
PHONE (919) 707-6690  
FAX (919) 250-4151

DONNA JACKSON, P.E. UTILITIES REGIONAL ENGINEER  
TODD LAPHAM UTILITIES COORDINATOR

6/8/2018  
R:\Utilities\Engineering\UC\Proj\Submittals\RFC Plans\B2500B\_UH1\_rsh.dgn  
mpyatt



# STATE OF NORTH CAROLINA DIVISION OF HIGHWAYS

## UTILITIES PLAN SHEET SYMBOLS

PROJECT REFERENCE NO. B-2500B	SHEET NO. UC-2
----------------------------------	-------------------

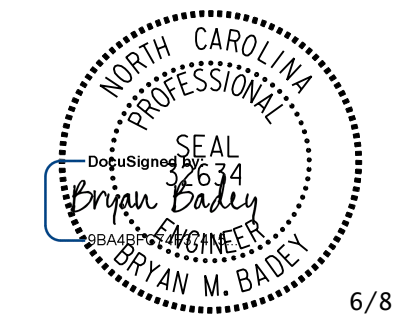
  
 6/8/2018  
 UTILITY CONSTRUCTION PLANS  
**DOCUMENT NOT CONSIDERED FINAL  
UNLESS ALL SIGNATURES COMPLETED**



### PROPOSED WATER SYMBOLS

Water Line (Sized as Shown)	
11 1/4 Degree Bend	
22 1/2 Degree Bend	
45 Degree Bend	
90 Degree Bend	
Plug	
Tee	
Cross	
Reducer	
Gate Valve	
Butterfly Valve	
Tapping Valve	
Line Stop	
Line Stop with Bypass	
Blow Off	
Fire Hydrant	
Relocate Fire Hydrant	
Remove Fire Hydrant	
Water Meter	
Relocate Water Meter	
Remove Water Meter	
Water Pump Station	
RPZ Backflow Preventer	
DCV Backflow Preventer	
Relocate RPZ Backflow Preventer	
Relocate DCV Backflow Preventer	

### PROPOSED SEWER SYMBOLS

Gravity Sewer Line (Sized as Shown)	
Force Main Sewer Line (Sized as Shown)	
Manhole (Sized per Note)	
Sewer Pump Station	

### PROPOSED MISCELLANEOUS UTILITIES SYMBOLS

Power Pole	
Telephone Pole	
Joint Use Pole	
Telephone Pedestal	
Utility Line by Others (Type as Shown)	
Trenchless Installation	
Encasement by Open Cut	
Encasement	

Thrust Block	
Air Release Valve	
Utility Vault	
Concrete Pier	
Steel Pier	
Plan Note	
Pay Item Note	

NOTE  
PAY ITEM

### EXISTING UTILITIES SYMBOLS

Power Pole		*Underground Power Line	
Telephone Pole		*Underground Telephone Cable	
Joint Use Pole		*Underground Telephone Conduit	
Utility Pole		*Underground Fiber Optics Telephone Cable	
Utility Pole with Base		*Underground TV Cable	
H-Frame Pole		*Underground Fiber Optics TV Cable	
Power Transmission Line Tower		*Underground Gas Pipeline	
Water Manhole		Aboveground Gas Pipeline	
Power Manhole		*Underground Water Line	
Telephone Manhole		Aboveground Water Line	
Sanitary Sewer Manhole		*Underground Gravity Sanitary Sewer Line	
Hand Hole for Cable		Aboveground Gravity Sanitary Sewer Line	
Power Transformer		*Underground SS Forced Main Line	
Telephone Pedestal		Underground Unknown Utility Line	
CATV Pedestal		SUE Test Hole	
Gas Valve		Water Meter	
Gas Meter		Water Valve	
Located Miscellaneous Utility Object		Fire Hydrant	
Abandoned According to Utility Records		Sanitary Sewer Cleanout	
End of Information			

\*For Existing Utilities  
 Utility Line Drawn from Record (Type as Shown)  
 Designated Utility Line (Type as Shown)

PLANS PREPARED BY :



RUMMEL, KLEPPER & KAHL, LLP  
 900 RIDGEFIELD DRIVE SUITE 350  
 RALEIGH, NORTH CAROLINA 27609-3960  
 NC LICENSE NO. F-0112 • (919) 878-9560

8/17/09

# UTILITY CONSTRUCTION

## GENERAL NOTES:

1. THE PROPOSED UTILITY CONSTRUCTION SHALL MEET THE APPLICABLE REQUIREMENTS OF THE NC DEPARTMENT OF TRANSPORTATION'S "STANDARD SPECIFICATIONS FOR ROADS AND STRUCTURES" DATED JANUARY 2012.

2. THE EXISTING UTILITIES BELONG TO DARE COUNTY WATER DISTRIBUTION .

3. ALL WATER LINES TO BE INSTALLED WITHIN COMPLIANCE OF THE RULES AND REGULATIONS OF THE NORTH CAROLINA DEPARTMENT OF ENVIRONMENTAL QUALITY, DIVISION OF WATER RESOURCES, PUBLIC WATER SUPPLY SECTION. ALL SEWER LINES TO BE INSTALLED WITHIN COMPLIANCE OF THE RULES AND REGULATIONS OF THE NORTH CAROLINA DEPARTMENT OF ENVIRONMENT QUALITY, DIVISION OF WATER RESOURCES, WATER QUALITY SECTION. PERFORM ALL WORK IN ACCORDANCE WITH THE APPLICABLE PLUMBING CODES.

4. THE UTILITY OWNER OWNS THE EXISTING UTILITY FACILITIES AND WILL OWN THE NEW UTILITY FACILITIES AFTER ACCEPTANCE BY THE DEPARTMENT. THE DEPARTMENT OWNS THE CONSTRUCTION CONTRACT AND HAS ADMINISTRATIVE AUTHORITY. COMMUNICATIONS AND DECISIONS BETWEEN THE CONTRACTOR AND UTILITY OWNER ARE NOT BINDING UPON THE DEPARTMENT OR THIS CONTRACT UNLESS AUTHORIZED BY THE ENGINEER. AGREEMENTS BETWEEN THE UTILITY OWNER AND CONTRACTOR FOR THE WORK THAT IS NOT PART OF THIS CONTRACT OR IS SECONDARY TO THIS CONTRACT ARE ALLOWED, BUT ARE NOT BINDING UPON THE DEPARTMENT.

5. PROVIDE ACCESS FOR THE DEPARTMENT PERSONNEL AND THE OWNER'S REPRESENTATIVES TO ALL PHASES OF CONSTRUCTION. NOTIFY DEPARTMENT PERSONNEL AND THE UTILITY OWNER TWO WEEKS PRIOR TO COMMENCEMENT OF ANY WORK AND ONE WEEK PRIOR TO SERVICE INTERRUPTION. KEEP UTILITY OWNERS' REPRESENTATIVES INFORMED OF WORK PROGRESS AND PROVIDE OPPORTUNITY FOR INSPECTION OF CONSTRUCTION AND TESTING.

6. THE PLANS DEPICT THE BEST AVAILABLE INFORMATION FOR THE LOCATION, SIZE, AND TYPE OF MATERIAL FOR ALL EXISTING UTILITIES. MAKE INVESTIGATIONS FOR DETERMINING THE EXACT LOCATION, SIZE, AND TYPE MATERIAL OF THE EXISTING FACILITIES AS NECESSARY FOR THE CONSTRUCTION OF THE PROPOSED UTILITIES AND FOR AVOIDING DAMAGE TO EXISTING FACILITIES. REPAIR ANY DAMAGE INCURRED TO EXISTING FACILITIES TO THE ORIGINAL OR BETTER CONDITION AT NO ADDITIONAL COST TO THE DEPARTMENT.

7. MAKE FINAL CONNECTIONS OF THE NEW WORK TO THE EXISTING SYSTEM WHERE INDICATED ON THE PLANS, AS REQUIRED TO FIT THE ACTUAL CONDITIONS, OR AS DIRECTED.

8. MAKE CONNECTIONS BETWEEN EXISTING AND PROPOSED UTILITIES AT TIMES MOST CONVENIENT TO THE PUBLIC, WITHOUT ENDANGERING THE UTILITY SERVICE, AND IN ACCORDANCE WITH THE UTILITY OWNER'S REQUIREMENTS. MAKE CONNECTIONS ON WEEKENDS, AT NIGHT, AND ON HOLIDAYS IF NECESSARY.

9. ALL UTILITY MATERIALS SHALL BE APPROVED PRIOR TO DELIVERY TO THE PROJECT. SEE 1500-7, " SUBMITTALS AND RECORDS" IN SECTION 1500 OF THE STANDARD SPECIFICATIONS.

10. PRIOR TO COMMENCEMENT OF WATER AND SEWER CONSTRUCTION, CONTRACTOR SHALL CONTACT KEN FLATT (KENF@DARENC.COM), PATRICK IRWIN (PAT.IRWIN@DARENC.COM) AND SAMMY MIDGETT (SAMMYM@DARENC.COM)

11. ANY DAMAGE TO THE EXISTING DARE COUNTY WATER AND SANITARY SEWER LINES DURING CONSTRUCTION SHALL BE REPAIRED BY THE CONTRACTOR.

PROJECT REFERENCE NO.	SHEET NO.
B-2500B	UC-3

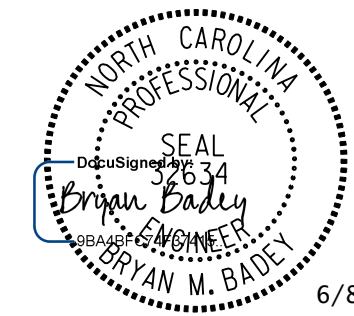

UTILITY CONSTRUCTION PLANS

**DOCUMENT NOT CONSIDERED FINAL UNLESS ALL SIGNATURES COMPLETED**



8/15/2018 8:17:11 AM C:\Users\Engineering\Nuc\Proj\Submittals\RFC\_Plans\B2500B\_Utl\_Psh03.dgn

PLANS PREPARED BY :



RUMMEL, KLEPPER & KAHL, LLP  
900 RIDGEFIELD DRIVE SUITE 350  
RALEIGH, NORTH CAROLINA 27609-3960  
NC LICENSE NO. F-0112 • (919) 878-9560



8/17/99

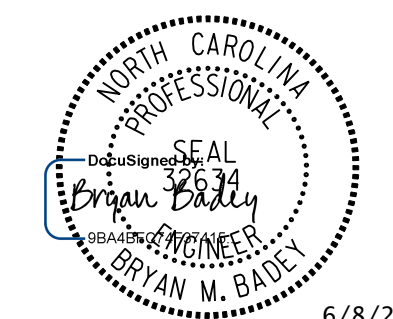

6/8/2018

UTILITY CONSTRUCTION PLANS  
DOCUMENT NOT CONSIDERED FINAL  
UNLESS ALL SIGNATURES COMPLETED

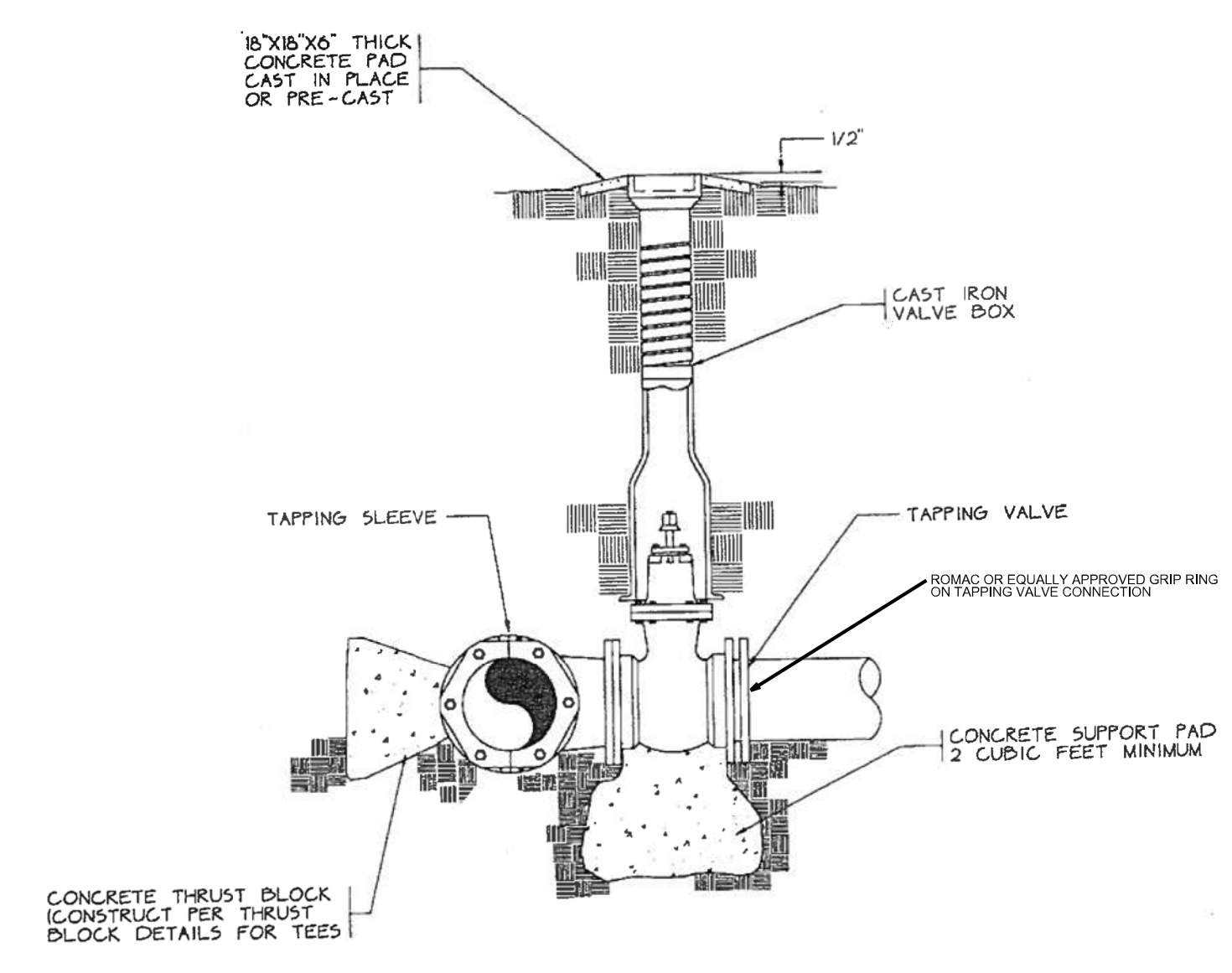

**TAPPING SLEEVE AND VALVE ASSEMBLY**  
N.T.S.

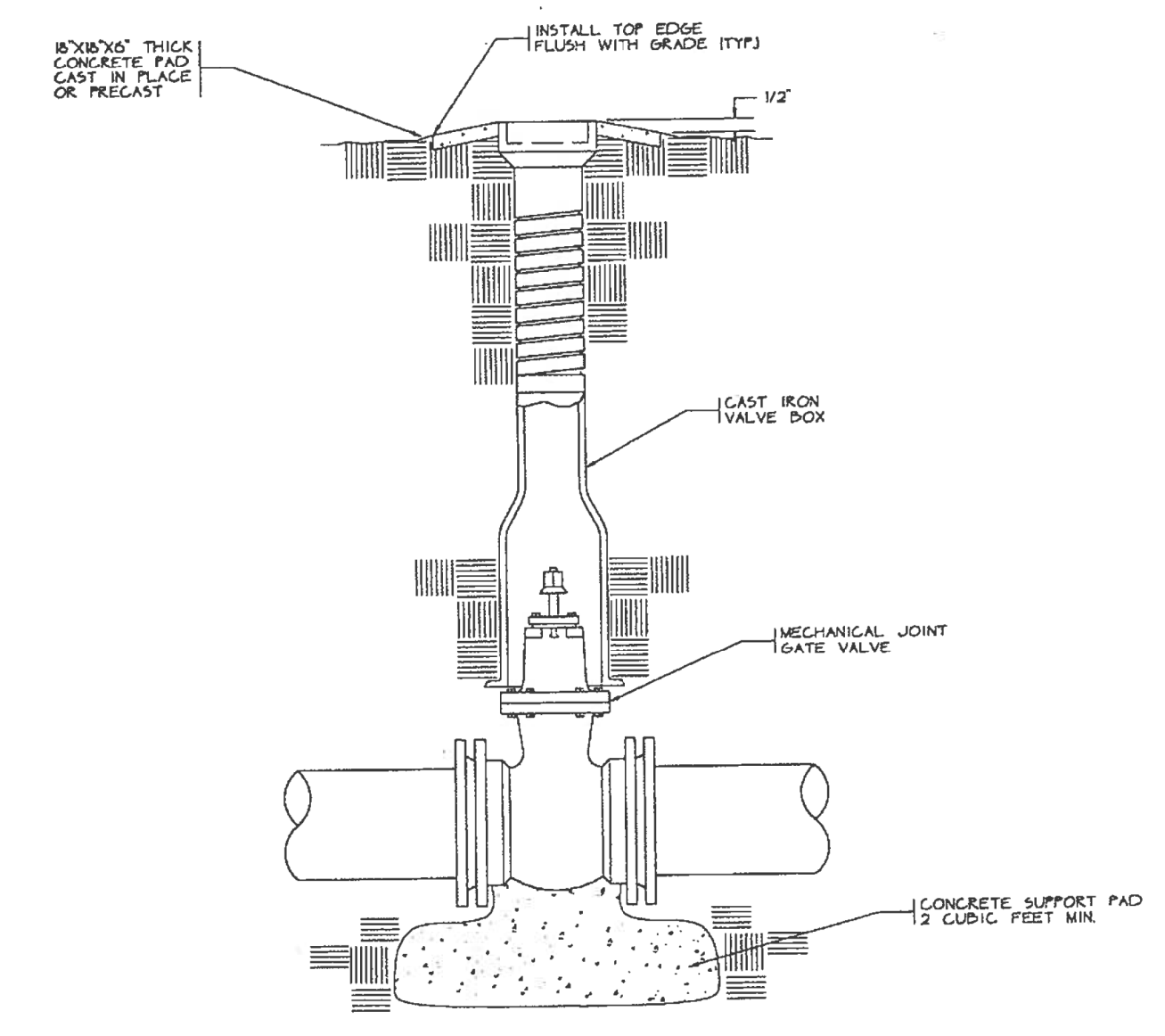

**GATE VALVE ASSEMBLY**  
N.T.S.

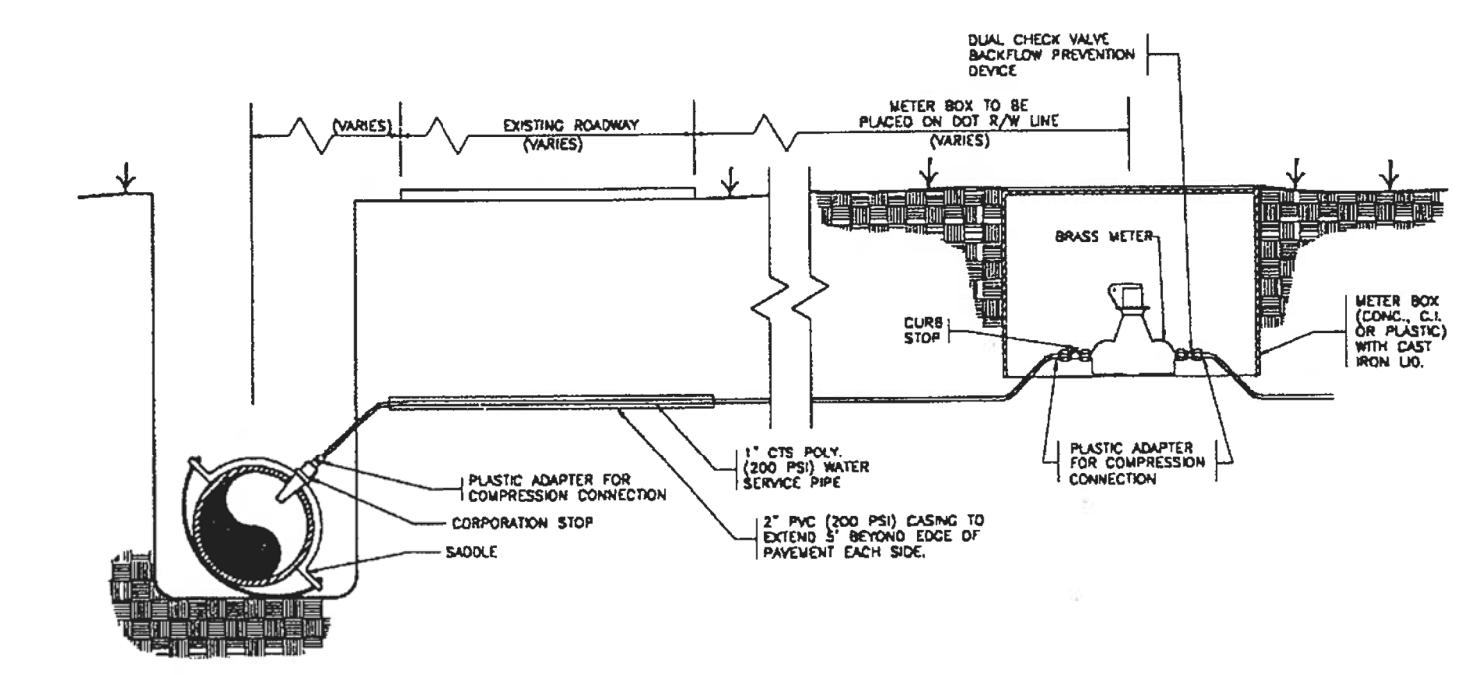

**TYPICAL SERVICE CONNECTION CROSSING ROAD**  
N.T.S.

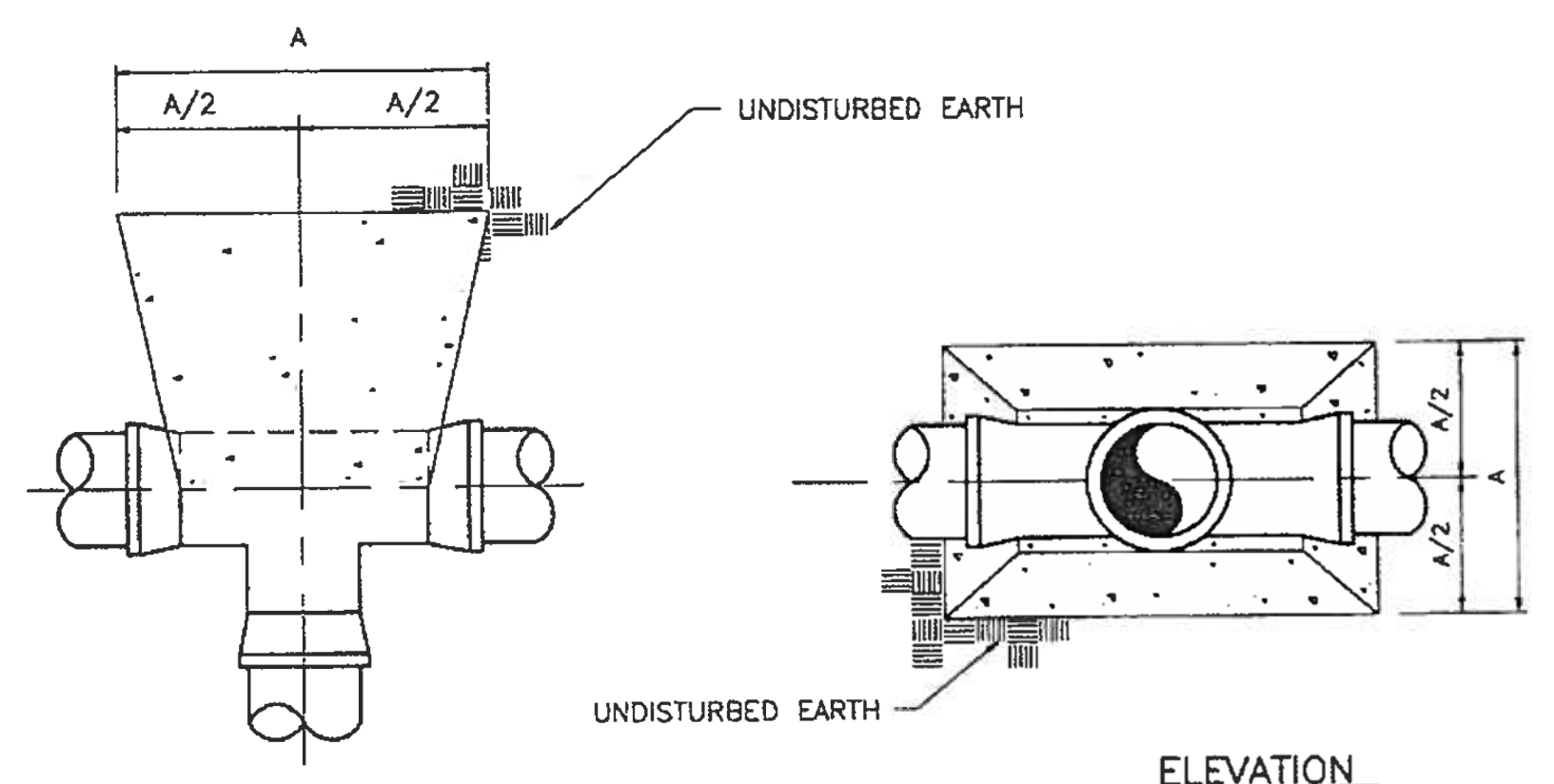

NOTE: THRUST BLOCK SIZE DETERMINED BY SMALLEST DIA. OF TEE

DIM. (IN INCHES)	PIPE SIZE (INCHES)										
	2	4	6	8	10	12	14	16	18	20	24
A	1.6	1.9	2.8	3.8	4.7	5.9	6.6	7.5	8.5	9.4	11.2

**THRUST BLOCK DETAIL FOR TEES**  
N.T.S.

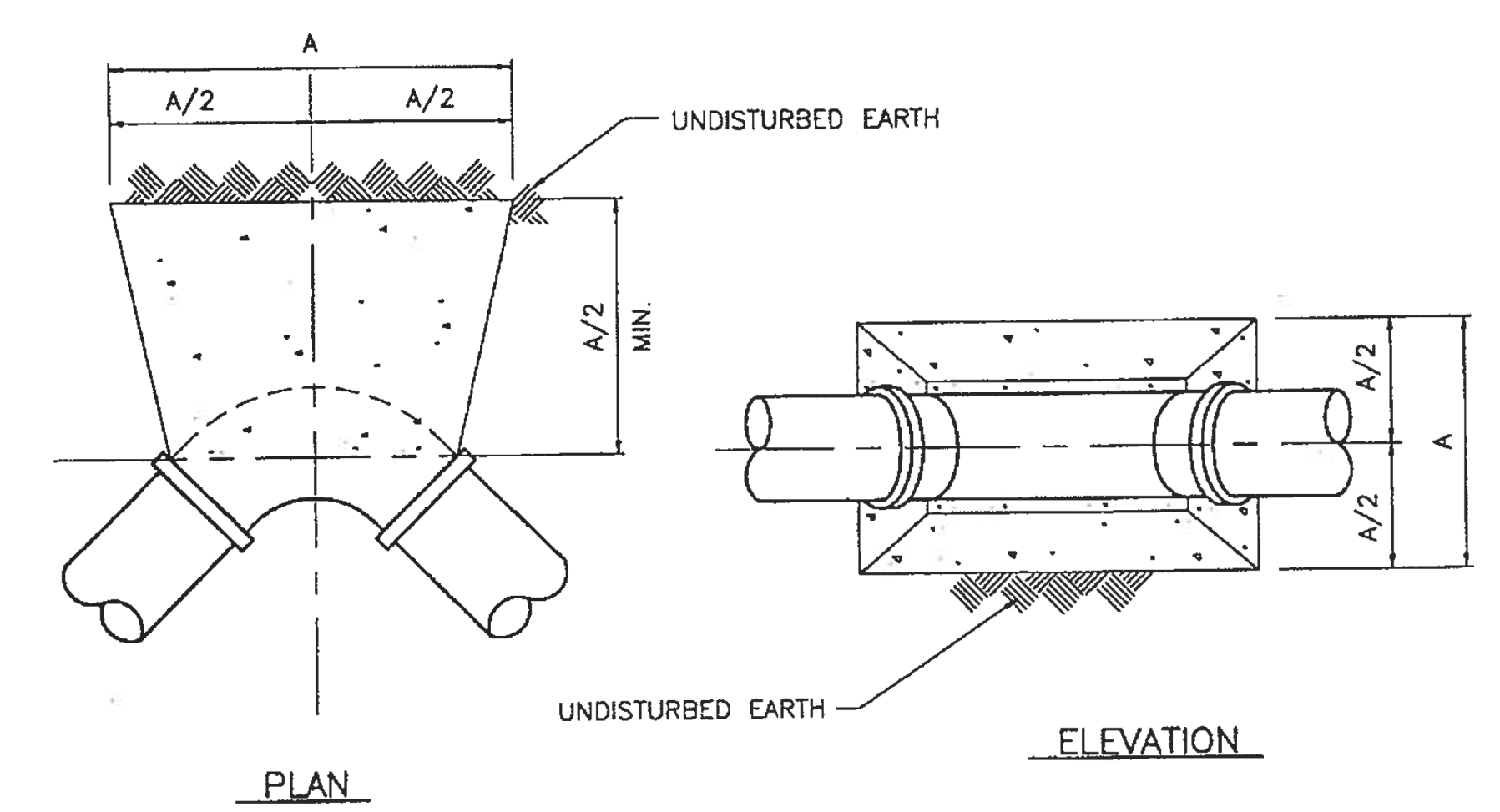

NOTE: THRUST BLOCKS SHALL BE CONSTRUCTED OF 2000 P.S.I. CONCRETE  
TABLE "A" DIMENSIONS (IN FEET)

BEND	PIPE SIZE (NOM. DIA. IN INCHES)									
	2	4	6	8	10	12	16	18	20	24
90°	1.5	1.9	2.8	3.8	4.7	5.9	7.5	8.5	9.4	11.2
45°	1.0	1.4	2.1	2.8	3.5	4.3	5.5	6.2	6.9	8.3
22 1/2°	0.8	1.0	1.5	2.0	2.5	3.1	4.0	4.5	4.9	5.7
11 1/4°	0.8	1.0	1.1	1.5	1.8	2.2	2.2	3.2	3.6	4.4

**THRUST BLOCK DETAIL FOR WATER MAIN BENDS**  
N.T.S.

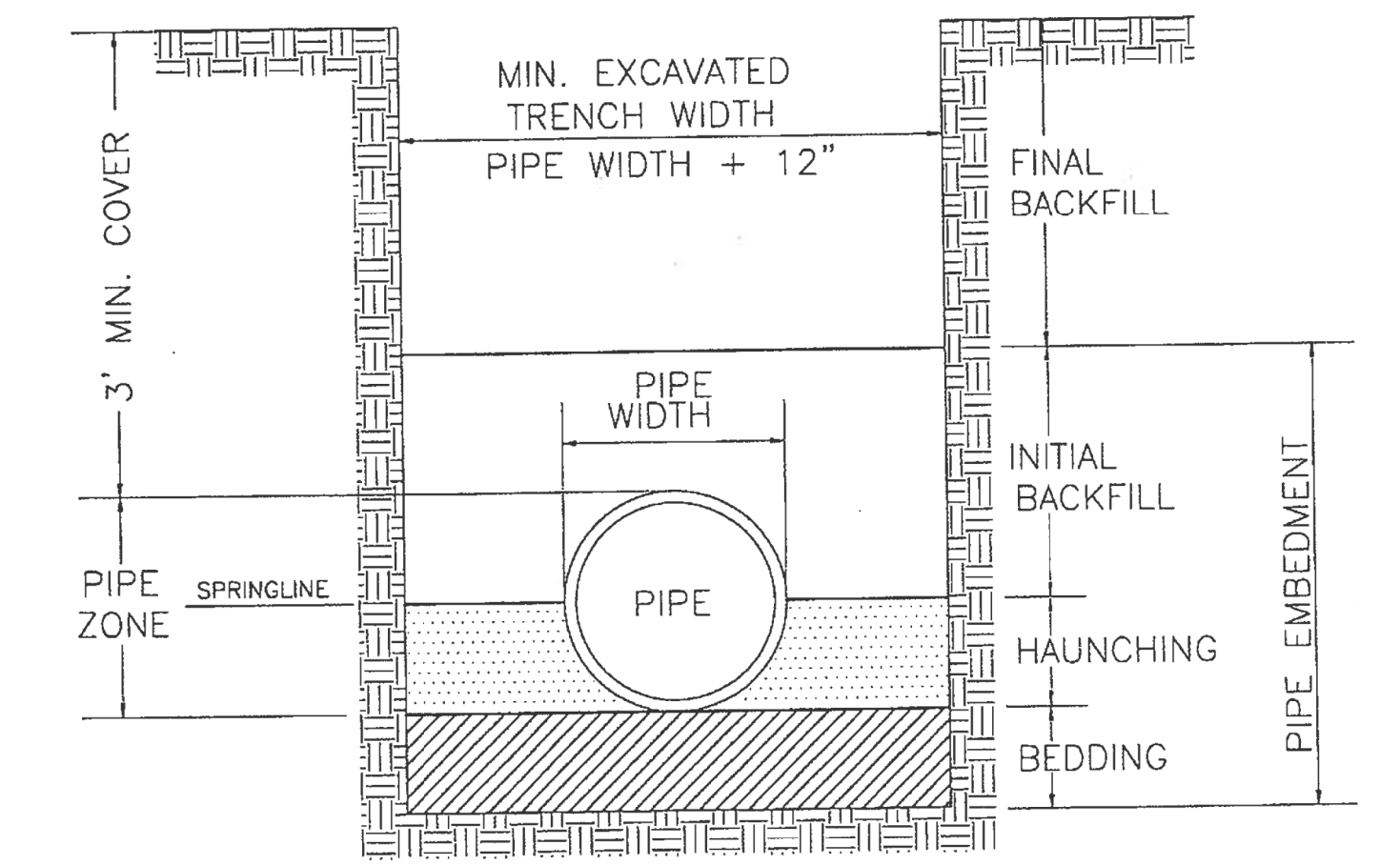

**TRENCH DETAIL**  
N.T.S.

PLANS PREPARED BY :  
**RK&K**  
RUMMEL, KLEPPER & KAHL, LLP  
900 RIDGEFIELD DRIVE SUITE 350  
RALEIGH, NORTH CAROLINA 27609-3960  
NC LICENSE NO. F-0112 • (919) 878-9560

8/15/2018 R:\Users\Engineering\UC\Proj\Submittals\RFC\_Plans\B2500B\_Utl1\_psh03a.dgn













6/8/2018

UTILITY CONSTRUCTION PLANS  
DOCUMENT NOT CONSIDERED FINAL  
UNLESS ALL SIGNATURES COMPLETED

NAD 83

**RFC**  
RELEASED FOR CONSTRUCTION

MATCHLINE -Y1- STA. 17+00 SEE SHEET UC-4

MATCHLINE -Y1- STA. 31+00 SEE SHEET 17

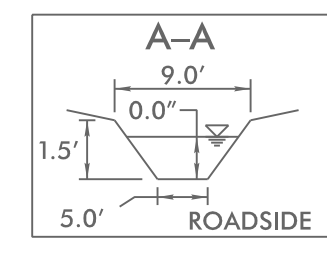
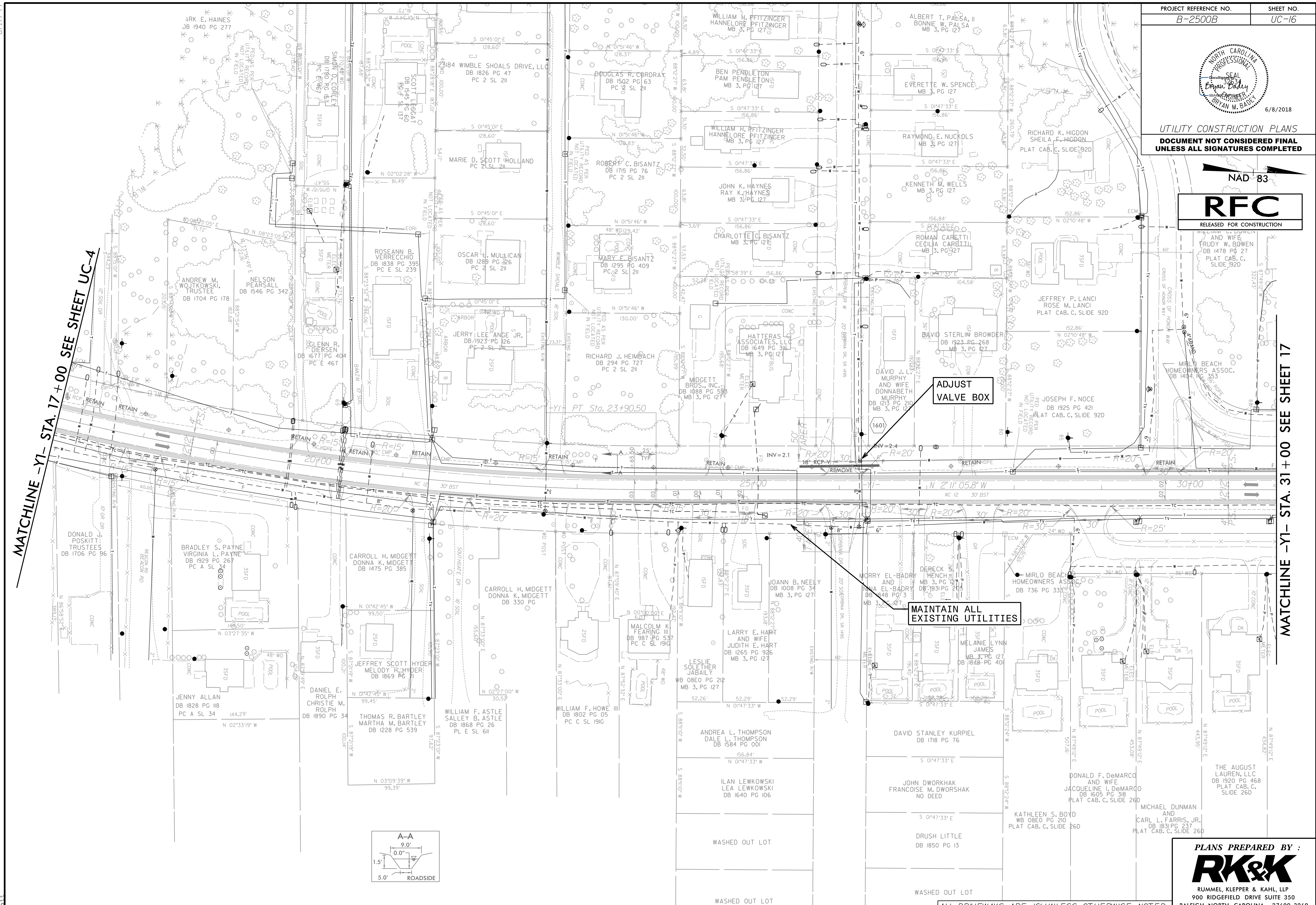

ALL DRIVEWAYS ARE 16' UNLESS OTHERWISE NOTED.  
ALL DRIVE RADII ARE 10' UNLESS OTHERWISE NOTED.

PLANS PREPARED BY :  
**RK&K**  
RUMMEL, KLEPPER & KAHL, LLP  
900 RIDGEFIELD DRIVE SUITE 350  
RALEIGH, NORTH CAROLINA 27609-3960  
NC LICENSE NO. F-0112 • (919) 878-9560

6/15/2018 R:\Utilities\Engineering\UC\Projects\Submittals\RFC Plans\B2500B.Ut1\_psh16.dgn

8/17/99



5/28/19

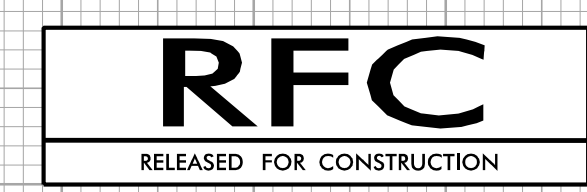

PROJECT REFERENCE NO. B-2500B	SHEET NO. UC-5
6/8/2018	
UTILITY CONSTRUCTION PLANS	
<b>DOCUMENT NOT CONSIDERED FINAL UNLESS ALL SIGNATURES COMPLETED</b>	

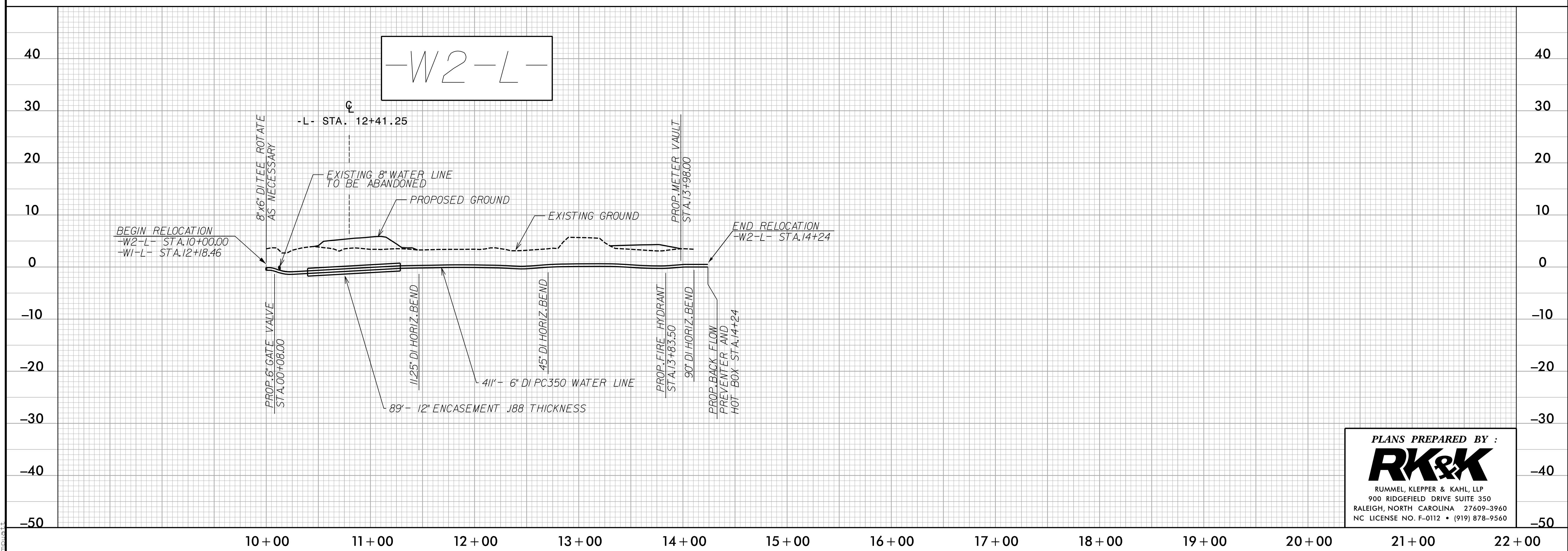
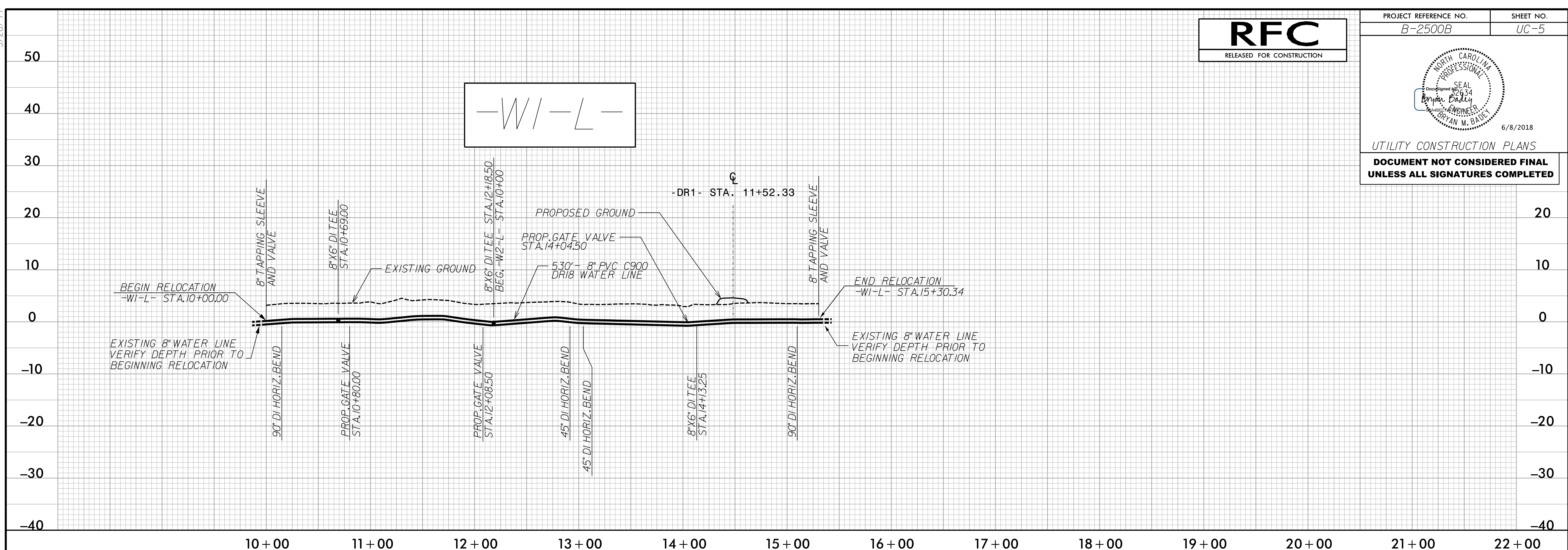

PLANS PREPARED BY :

RUMMEL, KLEPPER & KAHL, LLP  
 900 RIDGEFIELD DRIVE SUITE 350  
 RALEIGH, NORTH CAROLINA 27609-3960  
 NC LICENSE NO. F-0112 • (919) 878-9560

6/5/2018 8:17:15 AM C:\Users\Engineering\OneDrive\Projects\Submittals\RFC\_Plans\B2500B\_Utl1\_psh05.dgn





*Private Land Burning Agreement between Dare County (Owner) and US Fish and Wildlife Service (FWS)*

**Description**

Granting permission to the FWS and its authorized agents to enter onto the property, identified on the attached map, to implement a prescribed burn to burn vegetation in order to benefit the public interest, such as improved wildlife habitat, restoration and maintenance of valued ecosystems, control of pests and diseases, wildfire hazard reduction and other like benefits.

**Board Action Requested**

Approval

**Item Presenter**

Drew Pearson, Emergency Management Director

**Private Land Burning Agreement  
Grant of Permission to Burn Lands  
Not Administered by the US Fish & Wildlife Service**

**Name of the FWS Unit Involved:** Alligator River National Wildlife Refuge

**Name of the Private Land Owner:** County of Dare, NC

**Address:** 954 Marshall C. Collins Drive Box 1000 Manteo NC 27954

**Description of the lands covered by this Agreement (Attach map of lands pursuant to this agreement):**

The section of County-owned land north of Link Rd. adjacent to Refuge lands along the Rt. 264 corridor. This property is immediately north of the Dare County Landfill, and is identified within unit 2.1.5 on the attached map.

**Authorized Time Frame of this Permission:** Once signed this agreement will continue for a period of 10 years from the last signature and with notice to the other party may be terminated at will by either party at any time. During the agreement period, the FWS will:

1. Reconnoiter the land to determine if conditions have overtly changed since the agreement was originally completed
2. Review the land status for ownership changes
3. Contact the owner, via phone and/or letter, to inform the owner of our intent to burn per the conditions of the agreement. The owners point of contact for burn notification purposes is the Dare County Fire Marshal at (252) 475- 5751 or Dare County Fire Marshal, 954 Marshall C. Collins Drive Box 1000 Manteo NC 27954. Upon contact the Dare County Fire Marshal will confirm the agreement is still in effect, and that no conditions have changed. Burning will not occur without confirmation.

**Permission is hereby granted by the landowner (Owner) to the US Fish & Wildlife Service (FWS), and its authorized agents,** to enter onto the landowner property to implement the prescribed burn with equipment necessary for safe and efficient implementation of the burn as described above and identified on the attached map to burn the vegetation in order to obtain benefits in the public interest such as improved wildlife habitat, restoration and maintenance of valued ecosystems, control of pests and diseases, wildfire hazard reduction and other like benefits.

**The Owner gives permission on the following conditions:**

1. The FWS or their agent will write the prescribed fire plan (PFP) and will obtain all necessary permits.
2. The FWS will conduct the burn in accordance with the approved Prescribed Fire Plan.
3. The burn will be executed by the FWS using FWS personnel and/or their agents.
4. The FWS shall not charge the Owner for the cost of burning the Owner's lands.
5. If deemed necessary prior to the execution of the burn, the FWS will construct a firebreak (to the extent reasonably possible) along the perimeter of the burn unit identified above, and will also take reasonable steps to protect exposed fence posts and/or other critical areas at no expense to the Owner.
6. The Owner has inspected the above described lands and there are no buildings or personal property on these lands which the Owner desires or needs to be protected from the prescribed burn.

Therefore, the Owner agrees to hold the FWS harmless from any claims for his/her damaged or destroyed personal or real property located within the area authorized for prescribed burning.

7. The Owner will disclose knowledge of hazardous materials or hazardous conditions contained within the lands to be burned.
8. Any claim for personal injury or damages resulting from the negligence of FWS employees, or their assigned agent(s) must be filed in accordance with, and is subject to, the Federal Tort Claims Act (FTCA), 28 USC 2671 et seq.
9. Each party hereto agrees that, to the extent allowed by the FTCA and other applicable laws, it will be responsible only for its own contractual or tortious acts or omissions and the results thereof. Each party will therefore assume all risks and liability to itself, its agents or employees, for any injury to

persons or property resulting from actions or operations of itself, its agents or employees and for any loss, cost, damage or expense resulting at any time from any and all causes due to any acts, or negligence, or the failure to exercise proper precautions of or by itself or its own employees or agents to this agreement. Where both parties are found to share liability the degree of each party's liability shall be limited to its degree of culpability.

The following authorized representatives of the parties hereto have memorialized the above terms of agreement by executing this Agreement No. \_\_\_\_\_ in consideration of the anticipated mutual benefits it can provide:

**Owner/For the Owner\*:**

Name: Bobby Outten Date: \_\_\_\_\_

Title, if other than Fee Owner: County Manager/Attorney

Address 954 Marshall C. Collins Drive Box 1000 Manteo NC 27954

E-mail: outten@darenc.com

Phone (252) 475-5811

Signature: \_\_\_\_\_

**FWS Project Officer i.e. Local FWS Contact \*:**

Name: CB. Plante Date: \_\_\_\_\_

Title: Zone Fire Management Officer

Address: Alligator River NWR, 100 Conservation Way Manteo NC 27954

E-mail c\_plante@fws.gov

Phone (252)473-1131x236

Signature \_\_\_\_\_

**FWS Contracting & Grant Services (CGS):**

Name: \_\_\_\_\_ Date: \_\_\_\_\_

Title: \_\_\_\_\_

Signature \_\_\_\_\_

\* The signatory hereby certifies his or her legal right and authority to enter into binding agreements with regard to the identified parcel(s) of land.

CERTIFICATION OF CONDITIONS FOR USE OF APPROPRIATED FUNDS FOR IMPROVEMENTS TO PRIVATE PROPERTY (Reference 42 Comp. Gen. 480; 1963).

1. Appropriations for this project are otherwise available;
2. The improvements are determined to be incident to and essential for the effective accomplishment of the authorized purposes of the appropriation;
3. Expenditures for such purposes are in reasonable amounts;
4. The improvements are used for the principal benefit of the government;
5. The interests of the Government are fully protected with respect thereto.

\_\_\_\_\_  
US Fish and Wildlife Service Project Leader / Refuge Manager  
(Please print name)

\_\_\_\_\_  
Date

\_\_\_\_\_  
Signature

**Attachment 1 – Map of Lands Pursuant to this Agreement:**

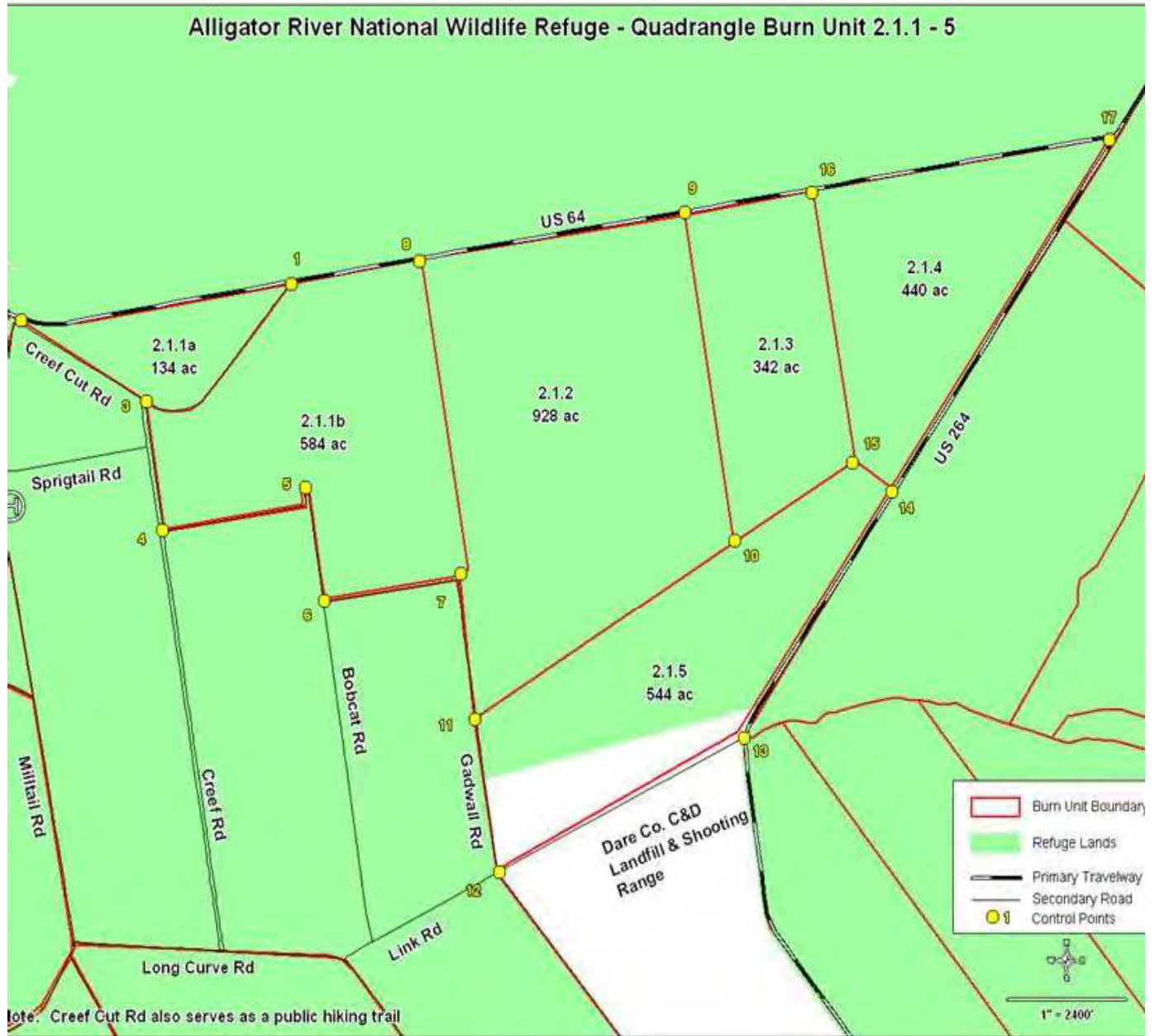



*Town Of Manteo Request - Delegate Approval of Pyrotechnics Permits*

**Description**

Pursuant to NCGS 14-413, the Town of Manteo has asked the Dare County Board of Commissioners to adopt a resolution delegating the approval of pyrotechnics permits within the corporate limits of Manteo. The Town already has the responsibility of code compliance on these type of events in their community and accepts the responsibility of inspection and issuance of the necessary pyrotechnics permits.

**Board Action Requested**

Approve a Resolution pursuant to NCGS 14-413

**Item Presenter**

Robert Outten, County Manager



April 25, 2019

Chairman Robert L. Woodard, Sr.  
Dare County Board of Commissioners  
P.O. Box 1000  
Manteo, NC 27954

Dear Chairman Woodard:

Pursuant to North Carolina General Statute 14-413, the County Board of Commissioners is charged with issuing permits for pyrotechnic displays even within City boundaries. Within this act there is language, which allows a County, upon adoption of a resolution, to pass this authority onto the cities in which the pyrotechnic displays will be held.

Within our Code of Ordinances, the Town of Manteo already has the responsibility of code compliance on these types of events. The Town of Manteo accepts the responsibility of inspection and the issuance of said permits for the fireworks display, held in the Town of Manteo.

We respectfully request the Dare County Board of Commissioners adopt a resolution passing the authority for the issuance and inspection of such a display onto the Town of Manteo.

Thank you for your consideration in this matter and should you have any questions, please do not hesitate to contact us.

Sincerely,

A handwritten signature in black ink, appearing to read "Bobby Owens", with a horizontal line underneath.

Bobby Owens  
Mayor



**A RESOLUTION OF APPROVAL BY THE DARE COUNTY BOARD OF COMMISSIONERS  
TO DELEGATE THE APPROVAL OF PYROTECHNICS PERMITS  
TO THE TOWN OF MANTEO**

**WHEREAS**, North Carolina General Statutes 14-410 and 14-413 seek to improve pyrotechnic safety in North Carolina; and

**WHEREAS**, General Statute 14-413(a1) provides that a board of county commissioners may authorize the governing body of any city in the county to issue permits pursuant to the provisions of this article for pyrotechnics to be exhibited, used, or discharged within the corporate limits of the city for use in connection with the conduct of concerts or public exhibitions; and,

**WHEREAS**, the resolution granting the authority to the city shall remain in effect until withdrawn by the board of county commissioners by adopting a subsequent resolution withdrawing the authority.

**WHEREAS**, this ratification shall be effective on the date of adoption of this resolution.

**NOW, THEREFORE BE IT RESOLVED THAT** the Dare County Board of Commissioners authorizes the governing body of the Town of Manteo to issue permits pursuant to the provisions of General Statute 14-413 for pyrotechnics to be exhibited, used, or discharged within the corporate limits of the city for use in connection with the conduct of concerts or public exhibitions.

This the 7<sup>th</sup> day of May, 2019

---

Robert Woodard, Chairman

Attest:

---

Gary Gross, Clerk to the Board





*NCDOT Utility Relocation Agreement*

**Description**

The Dare County Water Department is requesting that the NCDOT Utility Relocation Agreement (URA) be approved for water line re-alignment on Skyco Road & Toler Road for new culvert placement.

**Board Action Requested**

Approval of NCDOT Utility Relocation Agreement

**Item Presenter**

Pat Irwin, Assistant Utilities Director

\*\*\*\*\*

**UTILITY RELOCATION AGREEMENT**

**NCDOT HIGHWAY WBS ELEMENT NO.** \_\_\_\_\_

**TRANSPORTATION IMPROVEMENT PROGRAM NO.** \_\_\_\_\_

**COUNTY** \_\_\_\_\_

\*\*\*\*\*

This agreement made this \_\_\_\_\_ day of \_\_\_\_\_, 2019, by and between the Department of Transportation, an agency of the State of North Carolina, hereinafter referred to as the DEPARTMENT, and \_\_\_\_\_ Inc. hereinafter referred to as the COMPANY:

**WITNESSETH:**

**THAT WHEREAS, the DEPARTMENT will submit a project for construction as follows:**

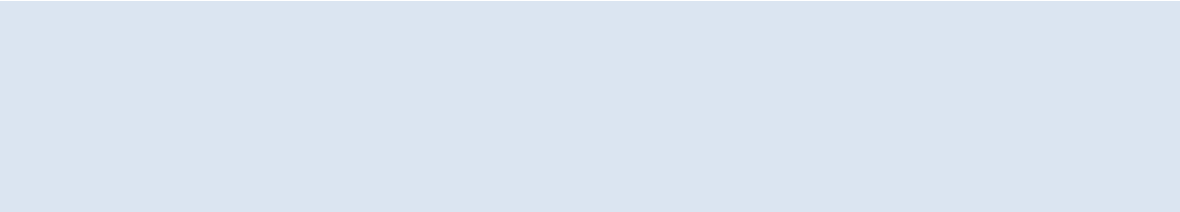

known as route \_\_\_\_\_ in \_\_\_\_\_ County, North Carolina to be designated as N.C. State Highway Project and/or WBS Element \_\_\_\_\_ and, WHEREAS, the construction of said project will require certain adjustments to be made to the existing facilities of the COMPANY;

**NOW, THEREFORE, in order to facilitate the orderly and expeditious relocation of the said facilities of COMPANY, the DEPARTMENT and the COMPANY have agreed as follows:**

**1. That the scope, description, and location of work to be undertaken by the COMPANY are as follows**

**2. That any work performed under this agreement shall comply with DEPARTMENT's "POLICIES AND PROCEDURES FOR ACCOMMODATING UTILITIES ON HIGHWAY RIGHTS OF WAY" dated January 1, 1975, and such amendments thereto as may be in effect at the date of this agreement. The work to be performed by the COMPANY shall conform with Federal Highway Administration's Federal-Aid Policy Guide, Subchapter G, Part 645, Subpart A hereinafter referred to as FAPG dated December 9, 1991, and such amendments thereto as may be in effect at the date of this agreement. The provisions of said FAPG and amendments thereto are incorporated in this agreement by reference as fully as if herein set out. Any work performed under this agreement not in compliance with FAPG shall constitute unauthorized work and the DEPARTMENT shall be relieved of participating in the costs of such unauthorized work unless such work is done pursuant to a supplemental agreement attached to and made a part hereof.**

**3. That the COMPANY will prepare an estimate, broken down as to estimated cost of labor, construction overhead, materials and supplies, handling charges, transportation and equipment, rights of way, preliminary engineering and construction engineering, including an itemization of appropriate credits for salvage and betterments, and accrued depreciation all in sufficient detail to provide the DEPARTMENT a reasonable basis for analysis. Unit costs, such as broad gauge units of property, may be used for estimating purposes where the COMPANY uses such units in its own operations. The COMPANY will also prepare plans, sketches or drawings showing their existing facilities, temporary and permanent changes to be made with reference to the DEPARTMENT's new right of way using appropriate nomenclature, symbols, legend, notes, color coding or the like. The before mentioned estimate and plans are attached hereto and made a part hereof. The DEPARTMENT will not reimburse the COMPANY for any utility relocations or changes not necessitated by the construction of the highway project, nor for changes made solely for the benefit or convenience of the COMPANY, its contractor, or a highway contractor.**

**4. That the DEPARTMENT's authority, obligation, or liability to pay for relocations as set forth in this agreement is based on the COMPANY having a right of occupancy in its existing location by reason of the fee, an easement or other real property interest, the damaging or taking of which is compensable in eminent domain.**

5. That payment for all work done hereunder shall be made in accordance with the requirements of FAPG unless payment is being made pursuant to a supplemental agreement attached to and made a part of this agreement.

6. That the construction work provided for in this agreement will be performed by the method or methods as specified below:

BY COMPANY'S REGULAR FORCE: The COMPANY proposes to use its regular construction or maintenance crews and personnel at its standard schedule of wages and working hours in accordance with the terms of its agreement with such employees.

BY EXISTING WRITTEN CONTINUING CONTRACT: The COMPANY proposes to use an existing written continuing contract under which certain work as shown by the COMPANY's estimate is regularly performed for the COMPANY and under which the lowest available costs are developed.

BY CONTRACT: The COMPANY does not have adequate staff or equipment to perform the necessary work with its own forces. The COMPANY proposes to award a contract to the lowest qualified bidder who submits a proposal in conformity with the requirements and specifications for the work to be performed as set forth in an appropriate solicitation for bids.

7. a. It is contemplated by the parties hereto that the construction of this State Highway Project will begin on or about the \_\_\_ day of \_\_\_\_\_, \_\_\_\_.

b. Based on the best information available at the present time to the COMPANY, indicate applicable paragraph below:

\_\_\_ Materials are available and it is expected that work will be complete prior to highway construction.

\_\_\_ All work will take place during highway construction and arrangements for said work will be coordinated with highway construction operations at preconstruction conference.

\_\_\_ Work will begin promptly upon notification by DEPARTMENT; however, it is not expected to be complete prior to highway construction. Any remaining work will be coordinated with highway construction operations at preconstruction conference.

\_\_\_ Other (Specify)

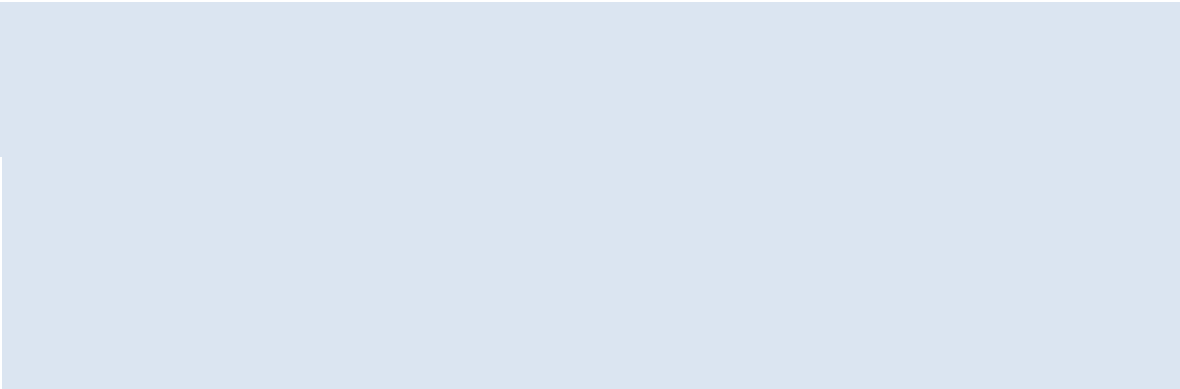

8. That the method used by the COMPANY in developing the relocation costs shall be as indicated by Paragraph (a), (b), or (c) as follows:

- a.  Actual direct and related indirect costs accumulated in accordance with a work order accounting procedure prescribed by the applicable Federal or State regulatory body.
- b.  Actual direct and related indirect costs accumulated in accordance with an established accounting procedure developed by the COMPANY and approved by the DEPARTMENT.
- c.  On a lump-sum basis where the estimated cost to the DEPARTMENT does not exceed \$100,000.00. Except where unit costs are used and approved, the estimate shall show such details as man-hours by class and rate; equipment charges by type, size, and rate; materials and supplies by items and price; and payroll additives and other overhead factors.

9. Indicate if (a) or (b) is applicable:

- a.  That the replacement facility is not of greater functional capacity or capability than the one it replaces, and includes no COMPANY betterments.
- b.  That the replacement facility involves COMPANY betterments, or is of greater functional capacity or capability than the one it replaces.

10. That the total estimated cost of the work proposed herein, including all cost to the DEPARTMENT and COMPANY less any credit for salvage, is estimated to be ----- \$ \_\_\_\_\_

The estimated non-betterment cost to the DEPARTMENT, including all cost less any credits for salvage, betterments, accrued depreciation and additional work done by the COMPANY will be ----- \$ \_\_\_\_\_

The estimated cost to the COMPANY including betterments, and any additional work done by the COMPANY will be ----- \$ \_\_\_\_\_

*(The above costs shall be supported by attached estimate and plans)*

11. That in the event it is determined there are changes in the scope of work, extra work, or major changes from the statement of work covered by this agreement, reimbursement shall be limited to costs covered by a modification of this agreement or a written change or extra work order approved by the DEPARTMENT.

**12. Periodic progress billings of incurred costs may be made by COMPANY to the DEPARTMENT not to exceed monthly intervals; however, total progress billing payments shall not exceed 95% of the approved non-betterment estimate. Progress billing forms may be obtained from the Area Utility Agent.**

**13. One final and detailed complete billing of all cost shall be made by COMPANY to the DEPARTMENT at the earliest practicable date after completion of work and in any event within six months after completion of work. The statement of final billing shall follow as closely as possible the order of the items in the estimate portion of this agreement.**

**14. That the DEPARTMENT shall have the right to inspect all books, records, accounts and other documents of the COMPANY pertaining to the work performed by it under this agreement at any time after work begins and for a period of 3 years from the date final payment has been received by the COMPANY.**

**15. That the COMPANY obligates itself to erect, service and maintain the facilities to be retained and installed over and along the highway within the DEPARTMENT right of way limits in accordance with the mandate of the Statute and such other laws, rules, and regulations as have been or may be validly enacted or adopted, now or hereafter.**

**16. That if, in the future, it becomes necessary due to highway construction or improvement to adjust or relocate utilities covered in this agreement being relocated at DEPARTMENT expense that are crossing or otherwise occupying highway right of way, the non-betterment cost of same will be that of the DEPARTMENT.**

**17. That if, at any time, the DEPARTMENT shall require the relocation of or changes in the location of the encroaching facilities covered in this agreement being relocated at COMPANY expense, the COMPANY binds itself, its successors and assigns, to promptly relocate or alter the facilities, in order to conform to the said requirements, without any cost to the DEPARTMENT.**

**18. That the COMPANY agrees to relinquish their rights in that portion of right of way vacated by their existing facilities now absorbed within DEPARTMENT right of way.**

**19. Proper temporary and permanent measures shall be used to control erosion and sedimentation in accordance with all local, State and Federal regulations.**

**20. The COMPANY agrees to comply with the environmental rules and regulations of the State of North Carolina. Violation to the NC Sedimentation Pollution Control Act, Clean Water Act, NC Coastal Management Act, or other environmental commitment outlined in the project permits may result in work stoppage, penalties and/or construction delays.**

**21. The COMPANY agrees to comply with Buy America. United States Codes (USC) 313 and Code of Federal Regulations 23 CFR 635.410: Requires the use of domestic steel and iron in all federally funded construction projects.**

**IN WITNESS WHEREOF, the parties hereby have affixed their names by their duly authorized officers the day and year first above written.**

**DEPARTMENT OF TRANSPORTATION**

**BY:** \_\_\_\_\_

**TITLE:** Division Utility Coordinator

**ATTEST OR WITNESS**

\_\_\_\_\_  
**(NAME OF COMPANY)**

**BY:** \_\_\_\_\_

**BY:** \_\_\_\_\_

**TITLE:** \_\_\_\_\_

**TITLE:** \_\_\_\_\_

**N.C.G.S. § 133-32 and Executive Order 24 prohibit the offer to, or acceptance by, any State Employee of any gift from anyone with a contract with the State, or from any person seeking to do business with the State. By execution of any response in this procurement, you attest, for your entire organization and its employees or agents, that you are not aware that any such gift has been offered, accepted, or promised by any employees of your organization.**

Form UT 16.8  
Rev.06/29/18



*Department of Health and Human Services - Social Services Division  
14-month Contract with Information, Inc.*

**Description**

DHHS plans to contract with Information, Inc. for the iireception program--a program which logs clients and assigns tasks.

The initial contract will begin in May and run through June 2020. All future contracts will cover a 12-month period from July - June.

**Board Action Requested**

Approve the 14-month contract for iireception from Information Inc.

**Item Presenter**

n/a



# Hosting and Maintenance Agreement

This Agreement is made this 1st day of May, 2019, between Information, Inc. (hereinafter "Consultant"), having its principal place of business at 9961 NC Hwy 87 N., Pittsboro, North Carolina 27312, and Dare County Department of Social Services (hereinafter "Client"), having its principal place of business at 107 Exeter Street, Manteo, NC 27954.

## Purpose

Client and Consultant enter into this Agreement in order to provide hosting and maintenance services for the iiReception application, as outlined in Supplement A attached to this agreement.

## Changes

Changes to any of the specifications for this Agreement or in this Agreement itself must be made in writing and agreed upon by both parties.

## Invoicing

Consultant will submit an initial invoice to Client for payment of hosting and maintenance services on the Commencement Date specified in Supplement A. Client may choose to pay for hosting and maintenance fees on a quarterly, semi-annual or annual basis, with Consultant providing invoices as such become due at the beginning of each invoice period. Invoices are due in full within 30 days. In the event of early termination of this Agreement by Client, Consultant shall be reimbursed for all reasonable costs and non-cancelable commitments incurred in the performance of this hosting agreement for which the Client has not yet paid.

## Hosting Services

In accordance with the terms of this agreement, Consultant will provide access to a customized version of the iiReception application for Client for the purposes logging client visits and assigning associated tasks to workers at the website address specified in Supplement A.

Consultant shall provide the following hosting services:

1. **Website Access.** Consultant shall provide Client with application level access to iiReception application via a secure (HTTPS) URL. Users of the application will be provided with a username and password to access the application. No direct access to server hardware, operating system, database management system or other system resources shall be provided.
2. **Data Storage.** Consultant shall store all Client data created and managed by the application, including files, text and parameters; data shall be backed-up on a separate storage system at regular intervals.
3. **Updates.** Consultant shall provide automatic application updates at no cost.

## Authorized Usage

Client agrees that access to applications shall be restricted to Dare County employees and shall use commercially reasonable efforts to protect User IDs and passwords. Consultant employees may access the system as required to diagnose and resolve technical issues. Client agrees that social security numbers should not be used or entered into the iiReception system.

## Service Commitment

Consultant will use reasonable efforts to make the application available with an Annual Uptime Percentage of at least 99.9% outside of maintenance windows (described below). Application availability is defined as the ability to log-on and access the hosting server. In the event that Consultant does not meet the Annual Uptime Percentage, Client will be eligible to receive a Service Credit equal to five percent (5%) of their bill.

## Maintenance

1. **Scheduled Maintenance.** To ensure optimal performance of the servers or to apply application updates, Consultant will perform routine maintenance on a regular basis, requiring servers to be removed from service. Consultant reserves one (1) hour of server unavailability per month for maintenance purposes. The maintenance is typically performed during off-peak hours. Consultant will provide Client with advanced notice of maintenance whenever possible.
2. **Emergency Maintenance.** Under certain circumstances, Consultant may need to perform emergency maintenance, such as security patch installation or hardware replacement. Consultant will not be able to provide Client with advanced notice in case of emergency maintenance.

## Maintenance Services

In accordance with the terms of this agreement, Consultant will furnish the installation, support, error-correction or customization services identified on Supplement A for the iiReception application.

## Ownership of Data

All data created by Client and/or stored by Client within Consultant's applications and servers are considered by Consultant to be Client property and are for Client's exclusive use unless access is permitted by Client. Consultant shall allow access to such data by authorized Consultant employees for maintenance and system administration purpose as appropriate only. In the event of the termination of this Agreement, Consultant shall furnish to Client a copy of all Client data within ten (10) business days.

## Data Integrity

Consultant employs sophisticated techniques to ensure the integrity of the data on its servers. Consultant performs routine server and application backups for disaster recovery purposes only. Server backup scope and scheduling is at Consultant's sole discretion. **Consultant shall not perform backup or restore the data upon Client's request unless such backup or restore is agreed upon in writing.**

## Data Retention

**Consultant shall not be responsible for retaining any of Client's data after termination of this agreement. After data is provided to Client in accordance with the Ownership of Data section of this Agreement, all data is deleted from Consultant servers.**

## Fees and Expenses

Client shall pay the Consultant the fee(s) set forth on Supplement A to this Agreement in full upon the Commencement Date of this agreement. The Consultant shall have the right to change the fee once each year, effective with the next renewal date, provided that: (i) the Consultant gives Client at least ninety (90) days prior written notice of any such change; and (ii) so long as the change is not an increase of more than ten percent (10%) of the then-current fee. Client shall pay the Consultant for services outside of the scope of this Agreement on time and material basis at the Consultant's then-prevailing rates, and only with the Client's prior written approval.

## Delivery and Acceptance

Client shall have four (4) weeks from receipt of each Deliverable or New Release to accept or reject the Deliverable in writing. In the event that Client rejects any Deliverable, it shall provide Consultant with a reasonably detailed description of its reasons for the rejection. Consultant shall promptly cure any identified deficiency that is within the parameters of the functionality of the application. The Deliverable shall be deemed accepted if Client does not notify Consultant of any material defects during the acceptance period or if Client makes beneficial use of the application. Acceptance shall not be unreasonably withheld.

Consultant will make itself available through electronic means and in person as required to assist Client in the use of the Deliverables as requested by client. All services furnished by Consultant following acceptance of Deliverable files shall be billed at the rate of \$100 per hour unless covered by this Agreement.

## Term and Termination

1. **Term of Agreement.** This Agreement shall commence on May 1, 2019 and will terminate on June 30, 2020.
2. **Termination of Agreement.** This Agreement shall terminate (i) immediately upon termination or expiration of Client's right to use the iiReception application; (ii) upon expiration of the then-current term; or (iii) upon thirty (30) days advance written notice if the other party has breached this Agreement and has not cured such breach within such notice period.
3. **Survival.** In the event of any termination of the Agreement, the Invoicing Section; Delivery and Acceptance Section; and Paragraph Ten (10) of the Miscellaneous Section hereof will survive and continue in effect and will inure to the benefit of and be binding upon the parties and their legal representatives, heirs, successors, and assigns, except that, in the event of early termination by Client prior to receipt of the final Deliverable, the warranties set forth in Paragraph Ten (10) shall be construed as to apply only to the work actually received, acknowledged, and accepted by Client as provided for in this Agreement.

## Client Support

1. **Level of Support.** The level of support that the Consultant can provide is dependent upon the cooperation of the Client and the quantity of information that the Client can provide. If the Consultant cannot reproduce a problem or if the Client cannot successfully gather adequate troubleshooting information, the Consultant may need temporary login access to the Client system to identify and address the problem.
2. **Client Responsibility.** The Client shall not distribute the application to any third party. The Client shall not make any modifications to the application. If any fixes are a result on non-authorized Client modifications to the application, this Agreement shall not apply and Client will be billed at the Consultant's standard hourly rate for corrections and time to troubleshoot the application.

## Miscellaneous

1. **Force Majeure.** Either party will be excused from delays in performing or from its failure to perform hereunder to the extent that such delays or failures result from causes beyond the reasonable control from such party; provided that, in order to be excused from delay or failure to perform, such party must act diligently to remedy the cause of such delay or failure.
2. **No Agency.** Consultant is not an agent of Client and is being retained only as an independent contractor. Consultant shall have no authority to bind or contract on behalf of Client and Consultant shall, under no circumstances, represent to any third-party that it has such authority to negotiate for or on behalf of Client, or bind Client to any obligation. Additionally, Consultant understands and affirms that any work performed on behalf of Client is being performed as an independent contractor and that no consideration paid to Consultant will be in the form of W-2 wages. Therefore, no withholding of any form of Federal or State income, Social Security or Medicare benefits will be made. Consultant understands that it is responsible for the payment of all such employment taxes, and agrees to hold Client harmless there from.
3. **Multiple Counterparts.** This Agreement may be executed in several counterparts, all of which taken together will constitute one single Agreement between the parties.
4. **Required Approvals.** Where Agreement, approval, acceptance, or consent by either party is required by any provision of this Agreement, such action will not be unreasonably delayed or withheld.
5. **No Waiver.** A delay or omission by either party in exercising any right or power under this Agreement will not be deemed to be a waiver of that right or power. Likewise, a waiver by either party as to any breach, covenant, condition or remedy under this Agreement or its amendments will not be construed



to be a waiver of any succeeding breach, covenant, condition or remedy. Unless stated otherwise, all remedies provided for in this Agreement will be cumulative and in addition to and not in lieu of any other remedies available to either party at law in equity or otherwise.

6. **Governing Law.** This Agreement will be governed by and construed in accordance with the laws of the State of North Carolina without regard for the choice of law provisions thereof.
7. **Entire Agreement.** This Agreement together with the Supplement A constitutes the entire Agreement between the parties. No change, waiver or discharge hereof will be valid unless it is in writing and is executed by the party against whom such change, waiver or discharge is sought to be enforced.
8. **Notices.** Under this Agreement if one party is required to give notice to the other, such notice will be deemed given if mailed by US Mail, First Class, Postage Prepaid and addressed as written above.
9. **No Assignment.** No assignment or transfer of this Agreement or any obligation incurred hereunder shall be made without the written consent of the other party. In the event of any merger, reorganization, consolidation or sale of all or substantially all the assets of either party, the consent of the other party to the assignment of this Agreement to the new, reorganized, reconstituted, or purchaser entity shall not be unreasonably withheld.
10. **Warranties.**
  - i) **Limited Warranty.** Consultant warrants only that it will perform all work in the Supplement A in a professional manner. Due to continuous changes to standards and conventions involved in application development and the common use of numerous different hardware and software platforms, **Client acknowledges that the Deliverable files may not work properly in all possible circumstances.** Application will be tested using Google Chrome. Consultant makes no warranty that the application to be maintained under this agreement will work properly other than when viewed with the latest version of Google Chrome. Any modification to the work performed by Client or any third-party on behalf of Client shall void all warranties, express or implied.
  - ii) **Non-infringement Warranty.** Consultant represents and warrants to the best of its knowledge and believes that the application, when properly used as contemplated herein, will not infringe or misappropriate any copyright, trademark, patent, or trade secrets of any third persons. Upon being notified of a claim contrary to such warranty, Consultant shall (i) defend through litigation or obtain through negotiation the right of Client to continue using the application; (ii) reword the application so as to make it non-infringing while preserving the original functionality, or (iii) replace the application with functionally equivalent software. If none of the foregoing alternatives provide an adequate remedy, Client may terminate all or any part of this agreement and recover amounts paid hereunder with respect to the infringing deliverable. Notwithstanding any other provision, Consultant shall indemnify and hold harmless Client from any loss or liability from the application's infringement or misappropriation of any copyright, trademark, patent, or trade secrets of any third persons.
  - iii) **Warranty Disclaimer.** **Except as specifically provided in this section ("Warranties") the Consultant hereby disclaims with respect to all services, software, custom work product or other deliverables provided hereunder, all express and implied warranties, including any implied warranties of merchantability, title, accuracy, integration or fitness for a particular purpose.**
11. **Severability.** If any provision of this Agreement or Scope of Work shall be unlawful, void, or for any reason unenforceable, then that section shall be deemed severable from this Agreement and shall not affect the validity and enforceability of any remaining provisions.

12. **Limitation of Remedies & Liabilities.** The Party acknowledges that the following provisions has been negotiated by them and reflect a fair allocation of risk.

Except as provided in Paragraph 10 above, Client's sole and exclusive remedies for Consultant's default hereunder shall be (i) to obtain the repair, replacement or correction of the defective application, services or deliverables to the extent warranted under Section 10 ("Warranties") or, if Consultant reasonably determines that such remedy is not economically or technically feasible, (ii) to obtain an equitable partial or full refund of amounts paid with respect to the defective application, services or deliverables.

**Consultant shall not be liable for any amount exceeding the total portion of the contract price actually paid by Client. In no event shall either party be liable, whether in contract, tort (including negligence) or otherwise, for any indirect, incidental or consequential damages (including lost savings, lost profit or business interruption even if notified in advance of such possibility) arising out of or pertaining to the subject matter of this agreement.**

13. **Miscellaneous.** This document constitutes the entire agreement between the parties with respect to the subject matter hereof and supersedes all other communications, whether written or oral. This agreement may be modified or amended only by a writing signed by the party against whom enforcement is sought. Except as specifically permitted herein, neither this agreement nor any rights or obligations hereunder may be transferred or assigned by either party without the others prior written consent and any attempt to the contrary shall be void. Neither party shall be liable for delays caused by events beyond its reasonable control. Any provision hereof found by a tribunal of competent jurisdiction to be illegal or unenforceable shall be automatically conformed to the minimum requirements of law and all other provisions shall remain in full force and effect. Waiver of any provision hereof in one instance shall not preclude enforcement thereof on future occasions. Headings are for reference purposes only and have not substantive effect.

**IN WITNESS WHEREOF**, Client and Consultant have caused this Agreement to be signed and delivered by their duly authorized officers, all as of the date first written above.

DARE COUNTY DEPARTMENT OF HEALTH  
AND HUMAN SERVICES

INFORMATION, INC.

\_\_\_\_\_

\_\_\_\_\_

By: Sheila F. Davies, PhD  
Director

By: \_\_\_\_\_

Dated: \_\_\_\_\_

Dated: \_\_\_\_\_

# Supplement A

## Website Address

Consultant shall make available the iiReception application at the following website address:  
[darereception.informationinc.net](http://darereception.informationinc.net)

## IP Address Restrictions

Consultant will restrict access to the iiReception application to selected IP addresses. Access should be granted to the following IP addresses:

_____	_____	_____
_____	_____	_____

## Setup and Hosting Fees

Consultant shall provide application hosting services based in exchange for the following fees:

*Hosting & Maintenance Fee: \$1,050/month, \$12,600/year*

*SSL Certificate Cost: \$100/year \*if an informationinc.net subdomain is chosen, this charge will be waived.*

## Commencement Date

The date on which services under this Agreement shall begin is May 1, 2019.

## Agreement Term

The Term of this Agreement shall be fourteen (14) months beginning on the Commencement Date specified above.

## Coverage of Maintenance Agreement

The application covered by this Agreement is as follows:

- iiReception application, including customizations to be made for Dare County, and any future versions offered by Consultant.

## Support and Maintenance Policy Descriptions

In accordance with the terms of this Agreement, the Consultant will furnish one or more of the following support services (the "Services") for the iiReception application. Hours that are part of this maintenance agreement may be applied towards any of these Services.

1. **Basic Operation Support.** Consultant can provide administrative support to aid in the configuration and customization of the application through the use of the Administrative interface.
2. **Training Sessions.** Consultant can provide training sessions for Administrators and regular users of the applications at such time and location as the parties mutually agree.
3. **Customizations and New Features.** Client may use maintenance hours for Consultant to customize certain aspects of the application or for the addition of new features. Consultant shall provide Client with an estimate of the number of hours required to complete the customization or feature request prior to any such work. If work exceeds the number of hours available as part of this Agreement, Consultant will provide an estimate of charges for approval prior to performing any such work.

## Maintenance Hours

Consultant shall provide eight (8) hours of maintenance and application support per application over a twelve (12) month period.

**Consultant Method of Contact**

The Consultant will provide the following communication mechanisms for the Client to use when asking for support:

(a) Telephone Support. Consultant shall maintain a telephone hotline during regular business hours (8:00am to 5:00pm Monday-Friday EST) to assist Client in reporting errors and in providing first-line support in the use and operation of the software.

(b) Email. Consultant shall make available a designated email address or contact person for application maintenance and support requests.

**Timeliness of Incident Resolution**

Consultant shall use reasonable effort to provide modifications or additions reported by the Client under the conditions of this Agreement set forth in the Client Support section. Consultant will make reasonable efforts to correct or provide work-around solutions for any errors, and if a work-around is the immediate solution, will make reasonable effort to provide a final resolution of the error. Reasonable effort will be made to respond to any support or maintenance requests within 24 business hours after receiving notice and sufficient information from the Client.

**New Releases**

The Consultant shall be responsible for providing technical support and correcting errors for the most recent release of the application provided to the Client as specified in the Delivery and Acceptance section of this Agreement.



***DARE COUNTY DEPARTMENT OF HEALTH AND HUMAN SERVICES  
PUBLIC HEALTH DIVISION  
CONTRACT WITH OUTER BANKS WOMENS CARE***

**Description**

The Dare County Department of Health and Human Services contracts with Outer Banks Womens Care for the provision of Obstetrical ultrasound prenatal, cervical screening and breast ultrasound.

Renewing the contract is a lengthy process. Therefore we would like to enter a three year contract with Outer Banks Womens Care.

**Board Action Requested**

Approve three year contract

**Item Presenter**



**AGREEMENT BETWEEN  
 OUTER BANKS PROFESSIONAL SERVICES, LLC D/B/A  
 OUTER BANKS WOMEN’S CARE  
 AND  
 DARE COUNTY DEPARTMENT OF HEALTH AND HUMAN SERVICES  
 FOR THE PROVISION OF OBSTETRICAL ULTRASOUND, PRENATAL, CERVICAL  
 SCREENING AND CYTOLOGY, AND BREAST ULTRASOUND AND  
 PROFESSIONAL SERVICES**

THIS AGREEMENT is dated for reference, February 10, 2019, and is effective as of the date of last signature (“Effective Date”), by and between Outer Banks Professional Services, LLC d/b/a Outer Banks Women’s Care (“OBPS”), and Dare County Department of Health and Human Services (“AGENCY”) (each a “Party,” collectively “the Parties.”)

**WITNESSETH**

WHEREAS, AGENCY provides women’s health services to residents of Dare County as appropriate, and as set forth in Exhibits A, B, and C, and

WHEREAS, AGENCY recognizes that many underinsured and uninsured women it serves are unable to access those services due to financial barriers, and AGENCY enters into this Agreement to reduce these barriers and improve access to care.

NOW THEREFORE, in consideration of the provisions set forth herein, and for other good and valuable consideration, the receipt and sufficiency of which are hereby acknowledged, the parties agree as follows:

1. SERVICES. Services provided are set forth in Exhibits A, B, and C
  - a. Exhibit A: Obstetrical Ultrasound
  - b. Exhibit B: Prenatal Services; and
  - c. Exhibit C: Cervical Screening and Cytology
  - d. Exhibit D: Breast Ultrasound and Professional Services
  - e. Exhibit E: BCCP Fee Schedule
  - f. Exhibit E (a): BCCP Fee Schedule (Loop Electrosurgical Excision Procedure) Bundled Fee
  
2. TERM: The term of this Agreement shall commence on March 1, 2019 and continue through Feb. 28, 2022. Thereafter, it may be renewed upon mutual written agreement of the Parties.
  
3. TERMINATION: This Agreement may be terminated at any time during the term of the Agreement upon thirty (30) days written notice by the Party desiring to terminate the agreement to the other Party.
  
4. ENTIRE AGREEMENT AND AMENDMENTS. This Agreement, together with any attached exhibits, contains the entire understanding between the Parties with respect to the subject matter hereof and supersedes all prior and contemporaneous written or oral

negotiations and agreements between them regarding this subject matter. This Agreement may be amended only in writing, which writing must be signed by each Party.

5. INDEPENDENT CONTRACTOR: The relationship between the parties to this Agreement shall be that of independent contractors, and no party shall be construed to be the agent, partner, employee, or joint venturer of the other party to the Agreement. The parties shall not exercise control or direct the manner in which other parties perform their duties hereunder except to assure compliance with this Agreement.
6. INSURANCE. To the extent required by North Carolina law, AGENCY shall maintain Worker's Compensation insurance covering AGENCY'S employees who provide services under this Agreement. AGENCY also agrees to procure and maintain, or cause to be procured and maintained, liability insurance covering claims, causes of actions, actions, losses, liabilities, damages, and expenses arising out of, caused by, or otherwise resulting from the acts or omissions of AGENCY, its employees, and agents, occurring while each is engaged in activities pursuant to this Agreement. The limits of the liability shall be at least One Million Dollars (\$1,000,000.00) per occurrence and Three Million Dollars (\$3,000,000.00) in the aggregate. The insurance must be provided by an insurance company with an A.M. Best rating of A- or above, an S&P rating of AA- or above, and/or a program of self-insurance approved by OBPS. AGENCY shall ensure that a current certificate of insurance or proof of self-insurance is supplied to OBPS at all times this Agreement is in effect. AGENCY shall provide OBPS with thirty (30) days advance written notice of any cancellation, change in policy limits, or any other material modification of this liability insurance policy. Any person or company who provides services pursuant to this Agreement, and who operates a motor vehicle (as defined by North Carolina General Statutes Section 20.4.01) while providing such services, whether such motor vehicle is owned, leased, hired or borrowed, shall, at all times during the term of this Agreement, hold a valid driver's license issued by a U.S. State or territory, and shall procure and maintain, or cause to be procured and maintained, automobile/vehicle insurance with minimum limits of One Hundred Thousand Dollars (\$100,000) per individual, Three Hundred Thousand Dollars (\$300,000) per accident and Fifty Thousand Dollars (\$50,000) property coverage.
7. HOLD HARMLESS AND INDEMNIFICATION: To the extent permitted under North Carolina law without waiving any defenses, AGENCY agrees to defend, indemnify and hold harmless OBPS, its directors/officers, trustees, employees, agents, subsidiaries, parent corporations, and affiliates ("OBPS Indemnitees") from any and all claims, demands, damages, or other financial demands (including, without limitation, reasonable attorneys' fees and expenses) due to any actions or omissions of AGENCY arising out of, or in connection with, this Agreement, except that AGENCY does not agree to indemnify and hold harmless the OBPS Indemnitees from any claims to the extent that they resulted solely from any error or omission by the OBPS Indemnitees. OPBS agrees to defend, indemnify and hold harmless AGENCY, its directors/officers, trustees, employees, agents, subsidiaries, parent corporations, and affiliates ("AGENCY Indemnitees") from any and all claims, demands, damages, or other financial demands (including, without limitation, reasonable attorneys' fees and expenses) due to any actions or omissions of OBPS, its employees or its agents arising out of, or in connection with, this Agreement, except that OBPS does not agree to indemnify and hold harmless the OBPS Indemnitees

from any claims to the extent that they resulted solely from any error or omission by the OBPS Indemnites.

8. ASSIGNMENT: This agreement is personal to each of the parties hereto, and neither party may assign nor delegate any of its rights or obligations without first obtaining the written consent of the other party, unless otherwise provided for in this Agreement. Any purported assignment without prior written consent from the other party shall be null and void.
9. NO REQUIREMENT TO REFER. To the extent that Stark and Fraud and Abuse concerns could be applicable to this Agreement and parties to this transaction, nothing in this Agreement, whether written or oral, nor any consideration in connection therewith, contemplates or requires the referral of any patients, goods, items, facilities, or services by AGENCY to Hospital or to any other entity affiliated in any way with Hospital. This Agreement is not intended to influence the judgment of AGENCY, its directors/trustees, officers, employees, agents, subsidiaries, parent corporations, and/or affiliates in choosing medical specialists or medical facilities appropriate for the proper care and treatment of patients. Neither AGENCY nor its employees or agents shall receive any compensation or remuneration for referrals, if any, to Hospital or any of Hospital's agents or affiliates.
10. RESTRUCTURING. It is the intention of the parties to comply with all applicable laws and regulations, including, but not limited to, the Internal Revenue Code of 1986, as amended, the Medicare and Medicaid Anti-Kickback statute, the "Stark II" anti-referral legislation, and any regulations promulgated thereunder. The parties acknowledge that legislation, regulations, an administrative ruling or other legally binding opinion may be adopted, amended, promulgated or issued which effectively renders this Agreement unlawful, could affect the tax-exempt status of either party or any affiliates thereof, could impose liability or exclusion from participation in the Medicare or Medicaid program or otherwise have a negative impact on either party. In the event of such a change of law which renders a portion of this Agreement unlawful or otherwise would have a negative impact on either of the parties to the Agreement or subject either of them to potential liability or exclusion from participation in the Medicare or Medicaid programs as a result of this Agreement or any of its terms, either party may, by written notice, propose a specific restructuring of this Agreement in order to establish full compliance. If such notice is given and the parties cannot agree with respect to restructuring within thirty (30) days of such notice, then any unlawful or otherwise negative provision potentially subjecting either party to liability or exclusion from participation in Medicare or Medicaid programs shall be deleted from the Agreement in its entirety. If the deletion of any said potentially unlawful or otherwise negative provision renders the overall purpose of the Agreement commercially unreasonable, unconscionable and/or impracticable for either party, then this Agreement shall automatically terminate.
11. OBRA COMPLIANCE. The parties agree that upon request they will make their books, documents, and records pertaining to the subject matter of this transaction available to the Secretary of Health and Human Services, the Comptroller General, or their duly authorized representative to the extent required by Section 952 of the Omnibus Budget Reconciliation Act of 1980 and will obtain a similar agreement from any related sub-

contractor whom they engage to perform on their behalf. Contractor further agrees, if required by law, it will retain any such records for at least four years after the end of any work based on this Agreement.

12. COOPERATION: In the event of any litigation against either party pertaining to any matter related to the other parties duties under this Agreement, both parties agree to reasonably cooperate with the other during the pendency of the claim or lawsuit including, without limitation, providing the other with all available information concerning the claim or lawsuit and meeting with the other or its representatives prior to giving testimony in connection with such claim or lawsuit, unless such cooperation adversely affects the party or the party is counseled by its attorney not to do so in order to preserve the attorney-client privilege. This Section survives termination of this Agreement.
13. EQUAL OPPORTUNITY: Neither party shall discriminate because of race, color, religion, sex, age, national origin, disability, or status as a Vietnam veteran, as defined by applicable law, in the recruitment, selection, training, utilization, promotion, termination or other employment related activities. In addition, each party affirms that it is an equal opportunity employer and shall comply with all applicable federal, state and local laws and regulations and 12086, 12138, 11625, and 12073; the Rehabilitation Act of 1973, as amended; the Vietnam Era Veterans Readjustment Assistance Act of 1975; Civil Rights Act of 1964; Equal Pay Act of 1963; Age Discrimination in Employment Act of 1967; Immigration Reform and Control Act of 1986; Public Law 95-507; the Americans With Disabilities Act; and any additions or amendments thereto.
14. ANTITRUST LAWS: The parties intend to comply and believe that this Agreement complies with all federal and state antitrust laws. However, upon at least seven (7) days' written notice, either party may terminate the Agreement for cause upon the occurrence of the commencement by the Department of Justice, Federal Trade Commission or other federal or state regulatory agency or department of a formal or informal investigation or inquiry concerning the legality of this Agreement.
15. NOTICE: Any notice required or permitted to be given hereunder shall be in writing and shall be given by personal delivery or by certified mail, return receipt requested, postage prepaid, to the following addresses:

Outer Banks Professional Services, LLC  
 d/b/a Outer Banks Women's Care  
 4810 S. Croatan Highway, Suite 100  
 Nags Head, NC 27959

Dare County DHHS  
 Attn: Sheila F. Davies, PhD,  
 Director  
 PO Box 669  
 Manteo, NC 27954

With copy to:  
 Vidant Health  
 Attn: Office of the General Counsel  
 P.O. Box 6028  
 2100 Stantonsburg Road  
 Greenville, NC 27835-6028



16. COSTS AND TAXES: Except as otherwise specifically provided by this Agreement, AGENCY shall bear AGENCY'S costs and expenses incurred in connection with the performance of AGENCY'S obligations pursuant to the Agreement. AGENCY shall be responsible for the payment of any and all federal, state, local and other taxes, which may arise or be imposed as the result of AGENCY'S performance under this Agreement or as the result of the receipt of any compensation or other funds under this Agreement.
17. THIRD PARTY BENEFICIARY: The parties do not intend to confer any rights, privileges, or benefits upon any other individual(s) or entity(ies) not signatories to this Agreement, arising out of this Agreement. The parties agree that nothing in this Agreement shall be construed or interpreted to confer any such rights, privileges, or benefits upon any individual or entity not a signatory to this Agreement.
18. SEVERABILITY. In the event that any portion of the Agreement is determined to be invalid or unenforceable, the remainder of the Agreement shall be deemed to continue and be binding upon the parties hereto in the same manner as the invalid or unenforceable provision were not part of the Agreement.
19. WAIVER. The failure by either party at any time to require performance by the other of any provision of the Agreement shall not affect in any way the right to require such performance at a later time nor shall the waiver by any party of a breach of any provision of the Agreement be taken or be held to be a waiver of such provision.
20. CHOICE OF LAW, JURISDICTION, AND VENUE. This Agreement has been entered into in the State of North Carolina. All questions with respect to the construction of this Agreement and the rights and liabilities of the Parties shall be governed by the laws of the State of North Carolina without regard to conflict of laws principles. Venue must be in the state or federal courts located in North Carolina for any actions between the Parties arising out of this Agreement.
21. CONFIDENTIAL INFORMATION: All information obtained by AGENCY in the performance of the services, or any information or materials developed or generated by AGENCY in the performance of the services, is confidential information ("Confidential Information"). AGENCY agrees to use all Confidential Information solely for the purposes of this Agreement, and not to directly or indirectly disclose such information to any third party, except with the prior written consent of OBPS and except as necessary to carry out the objectives of the Agreement. AGENCY agrees to exercise at least the same standards of care to protect the Confidential Information as is used to protect AGENCY'S own confidential and proprietary data from unauthorized disclosures, but no less than commercially reasonable standards. Notwithstanding the foregoing, AGENCY shall have no obligation of confidentiality with regard to any information insofar as the same: (i) was known to AGENCY prior to disclosure and not subject to a confidentiality obligation; (ii) is or becomes publicly available other than as a result of a breach of this Agreement; (iii) is disclosed to AGENCY by a third party not subject to an obligation of confidentiality; (iv) is independently developed by AGENCY without access to any Confidential Information; or (v) is produced in compliance with applicable law, securities reporting requirement, or a governmental or court order, provided OBPS is given notice and an opportunity to intervene. If AGENCY is requested or required by law or legal

process (e.g., by deposition, interrogatory, request for documents, subpoena, civil investigation, demand or similar process) to disclose any Confidential Information, AGENCY agrees to notify OBPS promptly so that OBPS may seek any appropriate protective order and/or take any other action. In the event that such protective order is not obtained, or that OBPS waives compliance with the provisions hereof, (a) there may be disclosed only that portion of the Confidential Information which OBPS is advised by legal counsel in writing is legally required to be disclosed, and OBPS shall use OBPS'S best efforts to assure that Confidential Information will be kept confidential; and (b) AGENCY shall not be liable for such disclosure unless such disclosure was caused by, or resulted from, a previous disclosure by AGENCY or any of OBPS representatives not permitted by this Agreement. Upon OBPS'S request, AGENCY will promptly deliver to OBPS (or destroy per OBPS specific instruction) all Confidential Information in AGENCY'S possession, without retaining any copy thereof. Upon OBPS'S request, AGENCY shall, in writing, certify compliance with the delivery or destruction request. AGENCY acknowledges and agrees that a violation of the provisions of this section would give rise to immediate, substantial, and irreparable harm to OBPS that could not be remedied at law. Upon such a breach, OBPS shall be entitled to preliminary and permanent injunctive relief, specific performance, and any other applicable remedies at law or in equity.

22. HIPAA. AGENCY represents and warrants that AGENCY may access PHI in the course of work performed under this Agreement and that AGENCY is a "Business Associate" of OBPS as defined under the privacy regulations promulgated pursuant to the Health Insurance Portability and Accountability Act of 1996, 42 U.S.C. Section 1320d et seq., as amended from time to time ("HIPAA"). AGENCY agrees, contemporaneously with the execution of this Agreement, to execute a Business Associate Agreement ("BAA"). The BAA Exhibit is attached to this Agreement and incorporated herein by reference. As used in this Agreement, PHI shall be defined as noted in the attached BAA Exhibit.
23. COUNTERPARTS. This Agreement may be executed and delivered in one or more counterparts, each of which may be deemed an original, but all of which constitute one and the same agreement. An executed counterpart transmitted by facsimile, electronic mail, or other form of electronic transmission to the other Party may be relied upon as an original.
24. GENDER: Throughout this Agreement, wherever the context requires or permits, the neuter gender shall be deemed to include the masculine and feminine and the singular number the plural, and vice versa.
25. HEADINGS: The headings and number sections and paragraphs contained in this Agreement are for reference purposes only and shall not effect in any way the meaning or interpretation of this Agreement.
26. SIGNATURES: As it is applicable to this Agreement, the parties agree to and adopt the terms and conditions of the Uniform Electronic Transactions Act, as adopted in North Carolina General Statutes Chapter 66, including but not limited to the provisions governing electronic signatures. As such, this Agreement is "signed" if it includes a digital signature, symbol and/or action that is adopted or performed by either party or party's

Electronic Agent with the present intent to authenticate or manifest assent to the Agreement.

**IN WITNESS WHEREOF**, each party has caused this Agreement to be executed by its duly authorized representative effective as of the date of last signature below.

**OUTER BANKS PROESSIONAL  
SERVICES, LLC D/B/A  
OUTER BANKS WOMEN'S CARE**

**DARE COUNTY DEPARTMENT OF  
HEALTH AND HUMAN SERVICES**

By:

By:

Name:

Name:

Title:

Title:

**EXHIBIT A**1. RESPONSIBILITIES OF OBPS:

OBPS agrees to:

- (a) Assist in the coordination of obstetrical ultrasounds, as requested
- (b) Provide interpretation of the ultrasound as part of the agreed upon fee and will provide written documentation to AGENCY of the interpretation results in the form of a Sonogram Report. Significantly abnormal results requiring urgent intervention will be called to the Maternal Health Nurse or Public Health Nursing Supervisor 1-Clinic (PHNS-1-C) in her absence. A written report will be made available within ten (10) working days of all sonograms performed.
- (c) Provide a copy of the office visit notes including a recommended action plan based on the Sonogram findings to the AGENCY.
- (d) Submit an invoice for contract services to the AGENCY for Obstetrical Ultrasounds authorized by the AGENCY.

2. RESPONSIBILTIES OF AGENCY

AGENCY agrees to:

- (a) Schedule referrals by telephone or email and follow with a written referral either by providing completed order forms to patients or by sending a faxed copy of the order form to OBPS.
- (b) Specify ultrasound indication (ie. Morphology, dating, growth) when arranging an authorized referral.
- (c) Specify non-stress test.
- (d) Specify non-stress test and AFI
- (e) Pay OBPS the sum of One-Hundred Fifty-Three Dollars and No/100 (\$153.00) for each obstetrical ultrasound including the interpretation
- (f) Pay OBPS the sum of Two Hundred Three Dollars and No/100 (\$203.00) for each biophysical profile ultrasound.
- (g) Pay OBPS the sum of fifty dollars (\$50.00) for the non-stress test
- (h) Pay OBPS the sum of eighty-nine dollars (\$89.00) for the non-stress test and AFI.



- (i) Pay OBPS the sum of Forty-Seven and No/Dollars (\$47.00) for the cost of the office visit when the visit includes direct patient contact with a physician who is providing interpretation of the ultrasound and is speaking with the patients regarding the results.

3. NUMBER OF SERVICES

AGENCY is not financially committed to the terms of this Agreement to purchase any minimum amount of services and payment will be made only from budgeted funds in accordance with NCGS 159. This is a “price only” contract and the AGENCY only agrees to pay OBPS for ultrasounds authorized by the Clinical Services’ Division Nursing Director or designee or the Maternal Health Nurse.

4. BILLING

OBPS agrees to submit a separate itemized bill on a monthly basis to the AGENCY. The bill should include the patient’s name and services provided by OBPS to AGENCY.

**EXHIBIT B****PROVISION OF PRENATAL SERVICES, POSTPARTUM CARE AND FAMILY PLANNING SERVICES****1. RESPONSIBILITIES OF OBPS**

OBPS agrees to:

- (a) Assure the availability of a physician specializing in the field of obstetrics and gynecology to serve as the supervising physician of record with the North Carolina Board of Nursing and the North Carolina Board of Medical Examiners for the certified nurse midwife employed by the AGENCY.
- (b) Review and approve, after any revisions required by the OBPS supervising physician, all standing orders required for the provision of prenatal services and family planning by mid-level providers, nurses, and other providers by the AGENCY.
- (c) Have its physicians and other providers address questions from the AGENCY mid-level providers (or their designees) regarding patient management issues, both obstetric and gynecologic; that may arise associated with maternal health and family planning. OBPS's physicians will allocate time to review patient charts with the AGENCY certified nurse midwife.
- (d) Provide evaluation and management services for patients of the AGENCY maternal health clinic upon request of the certified midwife, registered nurse coordinator, or Clinical Services Nursing Director or designee. Timeliness of evaluation and management provided will be determined by OBPS, with consideration being given to the medical exigency of the patient's condition and OBPS's capability of providing the needed service at the time requested. Billing and collection for these evaluation and management services will be performed by OBPS.

**2. RESPONSIBILITIES OF AGENCY**

- (a) Set up a nurse triage line to address patient questions and medical needs by telephone for those hours and days when it is closed.
- (b) Exercise its best efforts to staff, equip, and operate its maternal health and family planning clinic in a manner designed to ensure provision of high quality patient services.
- (c) Employ personnel, including, but not limited to, a certified nurse midwife, registered nurses, lab technicians, clerical staff, social workers, and other persons necessary to maintain continued provision of quality patient services.
- (d) Cooperate and communicate with OBPS on all matters related to OBPS providers providing support to the AGENCY maternal health and family planning clinics.

### 3. PLAN OF CARE-PRENATAL CLINIC

- (a) The Dare County Prenatal Clinic will operate under the standards of practice established by the North Carolina Department of Health and Human Services outlined in the annual addendum and the American College of Obstetricians and Gynecologists (hereinafter ACOG) as outlined in their current edition of "Guidelines for Prenatal Care."
- (b) AGENCY will see routine pregnancies and will coordinate referrals for consultation in accordance with the Early Pregnancy Risk Identification Standards and Ongoing Pregnancy Risk Identification Standards outlined in the ACOG Guidelines referenced above.
- (c) All patients will continue to receive services at the Health Department. Patients with increased risks as identified by the ACOG Guidelines who are referred out for Maternal Fetal Medicine/Obstetrician evaluation should return to the Health Department for co-management if the Provide or High Risk Clinic determines the patient to be medically appropriate for management in "low risk" setting and a clear plan of care for the patient will be made available to the provider at the AGENCY.
- (d) Frequency of visits will be determined by the individual needs of each patient, but the minimum standards as outlined by ACOG will be followed (uncomplicated pregnancy every four weeks for the first 28 weeks and every two to three weeks until 36 weeks gestation, and weekly thereafter).
- (e) Ultrasound ordered by providers will be scheduled at the appropriate facility.

### 4. PAYMENT FOR SERVICES

In consideration for specified contracted services as set forth in Paragraph 1 herein, the AGENCY will pay OBPS a monthly retainer of Three hundred and No/Dollars (\$300.00) and at a rate of Seventy-One and 50/100 Dollars (\$71.50) per hour for services rendered, including face to face visits, not to exceed Seven Thousand Dollars (\$7,000) per year. OBPS will submit a monthly invoice to the AGENCY for processing. The invoice will include a summary of monthly activities. Said fee shall be paid on a quarterly basis upon receipt of an invoice for services.

## EXHIBIT C

CYTOLOGY SCREENING AND CYTOLOGY PROFESSIONAL SERVICES  
AGREEMENT1. RESPONSIBILITIES OF OBPS

OBPS agrees to:

- (a) Provide colposcopy with or without endocervical curettage or biopsy at the reimbursement rates under the most current North Carolina Comprehensive Breast and Cervical Cancer Program (hereinafter "BCCCP") fee schedule
- (b) Use Lab Corp of America laboratory for interpretation of cervical biopsies (including ECC specimens) and pap smears utilizing Lab Corp of America's lab requisition form.
- (c) Schedule patients referred by the AGENCY to be seen within a three (3) week time period.
- (d) Receive, interpret, and notify AGENCY of the results of colposcopic evaluation and cervical biopsies.
- (e) For cervical biopsies showing squamous cell carcinoma, adenocarcinoma, or other malignant neoplasms, notify the AGENCY of the results and recommend follow-up by phone or fax within three (3) working days of receiving the results and send a written report by mail within four (4) weeks of receiving the results.
- (f) File any applicable claim with any public or private third party payor that a patient may be covered under and bill the BCCCP for the difference between the full amounts of the charges stated in Section 1(a) of this Exhibit "C" and the amount paid by the third party.

2. RESPONSIBILITIES OF AGENCY

AGENCY agrees to:

- (a) Identify patients eligible for services.
- (b) Perform initial screening smear and pelvic exam, and any follow-up pap smears as indicated.

- (c) Refer eligible patients to OBPS with the following documents:
  - a. BCCCP Consent (if applicable)
  - b. OBPS referral form
  - c. Copies of pertinent pap results
- (d) Contract with Lab Corp of America for cytological interpretation of pap smears and histological interpretation of cervical biopsy specimens and reimburse Lab Corp of America laboratory as specified in the Laboratory Service Contract for the BCCCP.
- (e) Assist with referrals for further care of patient as recommended by OBPS.
- (f) Pay scheduled colposcopy with or without endocervical curettage or biopsy and conization at reimbursement rates under the most current North Carolina Comprehensive BCCCP fee schedule (see Exhibit E attached)
- (g) AGENCY is not financially committed by the terms of this Agreement to purchase any minimum amount of services and payment will be made only from budgeted funds in accordance with NCGS Chapter 159. This is a “price only” contract and the AGENCY only agrees to pay OBPS for services authorized by the AGENCY Clinical Services Nursing Director, or designee, the AGENCY Clinical Services Nursing Supervisor and the BCCCP Nurse.
- (h) Make payments to OBPS within forty-five (45) days after receipt of itemized claim that does not exceed the charges stated in Paragraph 1(a) and (b) of this Agreement.
- (i) Notify OBPS if patient eligibility and/or authorization of services are cancelled for any reason.

## EXHIBIT D

BREAST ULTRASOUND AND PROFESSIONAL SERVICES1. RESPONSIBILITIES OF OBPS

OBPS agrees:

- (a) To provide MD office visits, breasts ultrasounds, and all other services covered by the North Carolina Breast and Cervical Center Program (NC BCCCP) Services Fee Schedule to clients referred to OBPS by AGENCY.
- (b) That for those patients who are BCCCP eligible, not to bill said patients for any additional charges for its services.
- (c) That no person, solely on the grounds of race, color, religion, age, sex, or national origin shall be excluded from participation in, be denied the benefits of, or be subjected to discrimination under any program or activity covered by this Agreement.
- (d) That no otherwise qualified, handicapped individual, solely by reason of his/her handicap, be excluded from participation in, be denied the benefits of, or be subjected to discrimination under any program or activity covered by this Agreement.
- (e) To ensure that the AGENCY receives a written report either by mail or fax to include the results of testing within two weeks of the appointment date.
- (f) To ensure that the AGENCY receives an itemized bill with CPT code on a monthly basis.

2. RESPONSIBILITIES OF AGENCY

AGENCY agrees to:

- (a) Pay OBPS the fee set up for the NC BCCCP Services Fee Schedule. The fee schedule, which changes each year on July 1, will be sent to OBPS annually.
- (b) Pay OBPS the unpaid balances of referred patients covered by a third-party payment source after evidence (Explanation of Benefits) of partial or non-payment has been furnished.
- (c) Provide to OBPS all pertinent information and demographics to bill patients' third party carriers.

3. GENERAL

Under the terms of this Agreement, AGENCY is not financially committed to purchase any minimum amount of services. Payment will only be made from budgeted funds in accordance with NCGS Chapter 159. This is a “price only” agreement.’

EXHIBIT E  
NCBCCCP Fee Schedule



## BUSINESS ASSOCIATE AGREEMENT

This Business Associate Agreement (“Agreement”) effective the date of last signature (“Effective Date”) is entered into by and between **Dare County Department of Health and Human Services** (“Business Associate”), and **Outer Banks Professional Services, LLC d/b/a Outer Banks Women’s Care** (“Covered Entity”). Business Associate and Covered Entity shall each be referred to herein as a “Party” and together as the “Parties”.

The Parties have an agreement, (the “Underlying Agreement”) under which Business Associate uses and/or discloses Protected Health Information (“PHI”) in its performance of the Services described below. This Business Associate Agreement supersedes any other Business Associate Agreement the Parties have previously entered into. The Parties are committed to complying with the Standards for Privacy of Individually Identifiable Health Information (the “Privacy Rule”) and the Standards for Security of Electronic Protected Health Information (the “Security Rule”) under the Health Insurance Portability and Accountability Act of 1996, Sections 261 through 264 of the federal Health Insurance Portability and Accountability Act of 1996, Public Law 104-191 (known as the “Administrative Simplification provisions”) and the Health Information Technology for Economic and Clinical Health Act (“HITECH” and hereinafter the Privacy Rule, the Security Rule, the Administrative Simplification provisions, HITECH, rules pursuant thereto, and amendments and modifications thereof, including any that are subsequently adopted, will be collectively referred to as “HIPAA”). This Agreement, in conjunction with HIPAA, sets forth the terms and conditions pursuant to which PHI (electronic and non-electronic) that is created, received, maintained, or transmitted by Business Associate from or on behalf of Covered Entity, will be handled between Business Associate and Covered Entity and with third parties during the term of the Underlying Agreement and after its termination. The Parties agree as follows:

### 1. PERMITTED USES AND DISCLOSURES OF PHI

1.1 Services. Pursuant to the Underlying Agreement, Business Associate provides services (“Services”) for Covered Entity that involve the use and disclosure of PHI. All such PHI is not the property of the Business Associate and shall be subject to this Agreement. Except as otherwise specified herein, Business Associate may make any and all uses of PHI necessary to perform its obligations under the Underlying Agreement. All other uses not authorized by this Agreement are prohibited. Moreover, Business Associate may disclose PHI for the purposes authorized by this Agreement only (i) to its employees, subcontractors and agents, in accordance with Section 2.1(d), or (ii) as otherwise permitted by or as required by HIPAA.

1.2 Business Activities of Business Associate. Unless otherwise limited herein and if such use or disclosure of PHI would not violate HIPAA if done by the Covered Entity, Business Associate may:

- a. use the PHI in its possession for its proper management and administration and to fulfill any present or future legal responsibilities of Business Associate provided that such uses are permitted under state and federal confidentiality laws.
- b. disclose the PHI in its possession to third parties for the purpose of its proper management and administration or to fulfill any present or future legal responsibilities of Business Associate, provided that (i) the disclosures are required by law, as provided for in 45 C.F.R. § 164.103 or (ii) Business Associate has received from the third party written assurances regarding its confidential handling of such PHI as required under 45 C.F.R. § 164.504(e)(4) and § 164.314, and the third party notifies Business Associate of any instances of which it is aware in which the confidentiality of the information has been breached.
- c. Business Associate may provide data aggregation services relating to the health care operations of the Covered Entity. For purposes of this Agreement, data aggregation services means the combining of PHI by Business Associate with the PHI received by Business Associate in its capacity as a business associate of another covered entity, to permit data analyses that relate to the health care operations of the respective covered entities.
- d. use PHI as necessary and contemplated by the Data Use Agreement between the parties to render the services defined therein.

### 2. RESPONSIBILITIES OF THE PARTIES WITH RESPECT TO PHI

2.1 Responsibilities of Business Associate. With regard to its use and/or disclosure of PHI, Business Associate hereby agrees to do the following:

- a. Not use or disclose PHI other than as permitted or required by the Agreement or as required by law, rule or regulation or by any accrediting organization to whom Covered Entity is required to disclose such PHI under this Agreement, the Underlying Agreement (if consistent with this Agreement and HIPAA) or HIPAA;

b. Use appropriate safeguards, and comply with Subpart C of 45 C.F.R Part 164 with respect to Electronic PHI, to prevent use or disclosure of PHI other than as provided for by the Agreement;

c. Report, in writing, to Covered Entity within ten (10) business days any use or disclosure of PHI not provided for by the Agreement of which it becomes aware, including breaches of unsecured PHI as required at 45 C.F.R § 164.410, and any "security incident" (as such term is defined in the Privacy Rule and the Security Rule) of which it becomes aware, and cooperate with the Covered Entity in any investigation, mitigation or breach reporting efforts;

d. Mitigate, to the extent practicable, any harmful effect that is known to Business Associate of any improper or unauthorized use or disclosure of PHI after informing the Covered Entity in advance of such efforts;

e. In accordance with 45 C.F.R § 164.502(e)(1)(ii) and 164.308(b)(2), if applicable, to ensure that any subcontractors that create, receive, maintain, or transmit PHI on behalf of Business Associate agree to substantially the same restrictions, conditions, and requirements that apply to Business Associate with respect to such information;

f. Comply with any requests for restrictions on certain disclosures of PHI pursuant to 45 C.F.R § 164.522 to which the Parties have agreed to in writing;

g. Within ten (10) business days of a request of Covered Entity, make available PHI in a designated record set, if applicable, to Covered Entity, as necessary to satisfy Covered Entity's obligations under 45 C.F.R § 164.524.

h. Notify Covered Entity within ten (10) business days of any request received from an individual for an amendment, and, within ten (10) business days, make any amendment(s) to PHI or make available to Covered Entity to make amendment(s), as applicable, in a designated record set as directed or agreed to by the Covered Entity pursuant to 45 C.F.R § 164.526, or take other measures as necessary to satisfy Covered Entity's obligations under 45 C.F.R § 164.526.

i. As applicable, maintain and make available to Covered Entity within ten (10) business days of a request of Covered Entity the information required to provide an accounting of disclosures as necessary to satisfy Covered Entity's obligations under 45 C.F.R § 164.528.

j. To the extent Business Associate is to carry out one or more of Covered Entity's obligation(s) under Subpart E of 45 C.F.R Part 164, comply with the requirements of Subpart E that apply to the Covered Entity in the performance of such obligation(s).

k. Upon request, cooperate with and make its internal practices, books, and records available to the Secretary and to the Covered Entity for purposes of determining compliance with the HIPAA Rules including without limitation 45 C.F.R § 164.502(b) and limits regarding limited data sets set forth in 45 C.F.R § 164.514.

l. Comply with minimum necessary requirements under the HIPAA Rules.

m. In addition, Business Associate will, pursuant to the HITECH Act and its implementing regulations, comply with all applicable requirements of the Security Rule, contained in 45 C.F.R §§ 164.308, 164.310, 164.312 and 164.316.

2.2 Responsibilities of Covered Entity. With regard to the use and/or disclosure of PHI by Business Associate, Covered Entity hereby agrees:

a. to inform Business Associate of any changes in, or revocation of, the permission by an individual to use or disclose PHI, to the extent that such limitation may affect Business Associate's use or disclosure of PHI.

b. to notify Business Associate, in writing and in a timely manner, of any restriction on the use or disclosure of PHI that Covered Entity has agreed to or is required to abide by under 45 C.F.R § 164.522, to the extent that such restriction may impact in any manner the use and/or disclosure of PHI by Business Associate under this Agreement. Except if Business Associate will use or disclose PHI for (and the Underlying Agreement includes provisions for) data aggregation or management and administration and legal responsibilities of Business Associate, Covered Entity will not request Business Associate to use or disclose PHI in any manner that would not be permissible under the HIPAA if done by the Covered Entity.

### 3. TERMINATION

a. Termination Rights. Upon Covered Entity's knowledge of a material breach of this Agreement by Business Associate, notwithstanding anything in this Agreement or the Underlying Agreement to the contrary, Covered Entity shall have the right to either:

(i) Provide an opportunity for Business Associate to cure the breach or end the violation and terminate this Agreement and the Underlying Agreement if Business Associate does not cure the breach or end the violation within the time specified by the Covered Entity; or

(ii) Immediately terminate this Agreement and the Underlying Agreement.

b. Obligations of Business Associate upon Termination. Upon Termination of this Agreement or the Underlying Agreement, Business Associate agrees to return or destroy all PHI pursuant to 45 C.F.R. § 164.504(e)(2)(I). Prior to doing so, Business Associate further agrees to recover any PHI in the possession of its subcontractors or agents. If it is not feasible for Business Associate to return or destroy said PHI, Business Associate will notify Covered Entity in writing. Said notification shall include: (i) a statement that Business Associate has determined that it is not feasible to return or destroy the PHI in its possession, and (ii) the specific reasons for such determination. Business Associate further agrees to extend any and all protections, limitations and restrictions contained in this Agreement to Business Associate's use and/or disclosure of any PHI retained after the termination of this Agreement, and to limit any further uses and/or disclosures to the purposes that make the return or destruction of the PHI infeasible. If it is infeasible for Business Associate to obtain, from a subcontractor or agent any PHI in the possession of the subcontractor or agent, Business Associate must provide a written explanation to Covered Entity and require the subcontractors and agents to agree to extend any and all protections, limitations and restrictions contained in this Agreement to the subcontractors' and/or agents' use and/or disclosure of any PHI retained after the termination of this Agreement, and to limit any further uses and/or disclosures to the purposes that make the return or destruction of the PHI infeasible.

### 4. MISCELLANEOUS

4.1 Business Associate. For purposes of this Agreement, Business Associate shall include the named Business Associate herein. However, in the event that Business Associate is otherwise a Covered Entity under HIPAA, that entity may appropriately designate a health care component of the entity, pursuant to 45 C.F.R. § 164.504(a), as Business Associate for purposes of this Agreement.

4.2 Survival. The respective rights and obligations of Business Associate and Covered Entity under Section 3 of this Agreement, shall survive termination of this Agreement indefinitely.

4.3 Amendments; Waiver. This Agreement may not be modified, nor shall any provision hereof be waived or amended, except in a writing duly signed by authorized representatives of the Parties. A waiver with respect to one event shall not be construed as continuing, or as a bar to or waiver of any right or remedy as to subsequent events. The Parties agree to take such action as is necessary to amend this Agreement from time to time as is necessary for compliance with the requirements of the HIPAA Rules and any other applicable law.

4.4 Interpretation. Any ambiguity in this Agreement shall be interpreted to permit compliance with HIPAA.

4.5 No Third Party Beneficiaries. Except as expressly stated herein or in the HIPAA Rules, nothing in this Agreement is intended to confer, nor shall anything herein confer, upon any person other than the Parties and the respective successors or assigns of the Parties, any rights, remedies, obligations, or liabilities whatsoever.

4.6 Notices. Any notices to be given hereunder to a Party shall be made via U.S. Mail or express courier to such Party's address given in the Underlying Agreement.

4.7 Disputes. If any controversy, dispute or claim arises between the Parties with respect to this Agreement, the Parties shall make good faith efforts to resolve such matters informally.

4.8 Changes in Law. The parties recognize that this Agreement is at all times subject to applicable state, and federal laws. The parties further recognize that this Agreement may become subject to amendments in such laws and regulations and to new legislation. Any provisions of law that invalidate, or are otherwise inconsistent with, the material terms and conditions of this Agreement, or that would cause one or both of the parties hereto to be in violation of law, shall be deemed to have superseded the terms of this Agreement and, in such event, the parties agree to utilize their best efforts to modify the terms and conditions of this Agreement to be consistent with the requirements of such law(s) in order to effectuate the purposes and intent of this set forth in an executed written agreement within thirty (30) days of receipt of notice from one party to the other party setting forth the proposed changes, then either party may, by giving the other an additional sixty (60) days written notice, terminate this Agreement, unless this Agreement would terminate earlier by its terms. In the event amendments or changes in existing law, general instructions, or new legislation, rules, regulations, or decisional law preclude or substantially preclude a contractual relationship between the parties similar to that expressed in this Agreement, then, under such circumstances, where renegotiation of the applicable terms of this Agreement would be futile, either party may provide the other at least sixty (60) days advance written notice of termination of this Agreement, unless this Agreement would terminate earlier by its terms. Upon termination of this Agreement as hereinabove provided, neither party shall have any further obligation hereunder except for (i) obligations occurring prior to the date of termination, and (ii) obligations, promises, or covenants contained herein which are expressly made and intended to extend beyond the term of this Agreement.

4.9 Construction of Terms. The terms of this Agreement shall be construed in light of any applicable interpretation or guidance on HIPAA and/or the Privacy Rule issued by the Department of Health and Human Services of the Office of Civil Rights from time to time.

4.10 Contradictory Terms. Any provision of the Underlying Agreement that is directly contradictory to one or more terms of this Agreement ("Contradictory Term") shall be superceded by the terms of this Agreement as of the Effective Date of this Agreement to the extent and only to the extent of the contradiction, only for the purpose of the Covered Entity's compliance with HIPAA and only to the extent that it is reasonably impossible to comply with both the Contradictory Term and the terms of this Agreement.

4.11 Minimum Standards. The provisions of this Agreement are intended to establish the minimum requirements regarding Business Associate's use and disclosure of PHI.

## 5. DEFINITIONS.

The following terms used in this Agreement shall have the same meaning as those terms in the HIPAA Rules: Breach, Designated Record Set, Disclosure, Health Care Operations, Individual, Minimum Necessary, Notice of Privacy Practices, Protected Health Information, Required By Law, Secretary, Security Incident, Subcontractor, Unsecured Protected Health Information, and Use. Specific definitions include:

a. Business Associate. "Business Associate" shall generally have the same meaning as the term "business associate" at 45 C.F.R § 160.103, and in reference to the party to this Agreement, shall mean the party defined on the first page of this Agreement as the "Business Associate".

b. Covered Entity. "Covered Entity" shall generally have the same meaning as the term "Covered Entity" at 45 C.F.R § 160.103, and in reference to the party to this agreement, shall mean the party defined on the first page of this Agreement as the "Covered Entity".

c. HIPAA Rules. "HIPAA Rules" shall mean the Privacy, Security, Breach Notification, and Enforcement Rules at 45 C.F.R Part 160 and Part 164.

d. Electronic Protected Health Information or Electronic PHI. PHI which is created in, transmitted by, or maintained in Electronic Media (as defined in the HIPAA Security and Privacy Rule).

e. Privacy Rule. Privacy Rule shall mean the Standards for Privacy of Individually Identifiable Health Information at 45 C.F.R. part 160 and part 164.

f. Security Rule. Security Rule shall mean the Standards for Security of Electronic Protected Health Information at 45 C.F.R Parts 160, 162, and 164.

IN WITNESS WHEREOF, each of the undersigned has caused this Agreement to be duly executed in its name and on its behalf.

**Covered Entity**

By:

Name:

Title:

**Business Associate**

By:

Name:

Title:





*Register of Deeds - Software License and Support Agreement*

**Description**

Enclosed is a software agreement for the recording software used by the Register of Deeds office. This is a 2 year agreement. There is no increase in price and no changes from the last contract.

**Board Action Requested**

Approval

**Item Presenter**

Cheryl House / Register of Deeds

## **Courthouse Computer Systems – Software License and Support Agreement**

AGREEMENT made by and between Courthouse Computer Systems, Inc., (“Licensor”) and the Dare County Register of Deeds office (“Licensee”).

The “Agreement” covers data conversion, licensing, software support and website maintenance for a contract period of July 1<sup>st</sup> 2019 through June 30<sup>th</sup> 2021 as outlined below:

### **1. Definitions**

- 1.1. “Designated Environment” means the computer equipment currently in place in the office
- 1.2. “Error” means a material failure of the Software to function in conformity with the Specifications
- 1.3. “Licensed Copies” means the number of copies of the Software being licensed to the Licensee
- 1.4. “Location(s)” means the Licensee office at Dare County Justice Center
- 1.5. 962 Marshall C Collins Dr Room 165A Manteo, NC 27954
- 1.6. “Office” means the Dare County Register of Deeds office.
- 1.7. “Software” refers to any of the supported software modules defined in section two of this Agreement.

### **2. Software Modules Included**

1. Document Recording and Cashiering
2. Document Indexing
3. Document Retrieval
4. Document Imaging
5. Internet Document Retrieval
6. Fee Reporting
7. Vital Records Management
8. Marriage License Issuance
9. Online Marriage Application (both Internet and office kiosk)
10. Image Redaction

Functionality incorporated within these software modules includes, but is not limited to:

1. The ability to easily export records in the system to an ASCII text file format to ensure forward compatibility without costly data conversion if the county decides to switch to a different software vendor at a later date. This guarantees complete safety and security by ensuring that your data will always be readable in the future. The Register of Deeds office can create and store these files on a daily basis.
2. The seamless integration of Point Of Sale (POS) stations with the indexing system. The POS module operates as the office cash register by controlling the cash drawer, printing receipts, and producing detailed ledger reports of all transactions.



3. The immediate accessibility of recorded documents for in-office retrieval. If desired, original documents may be scanned immediately for viewing on retrieval stations throughout the office.
4. The automatic generation of monthly reports that reference the complete set of financial data maintained in the system.
5. The ability to print traditional index books on-demand.
6. The ability to print traditional document books on-demand.
7. The ability to back-index and back-scan vital records.
8. The ability to back-scan document books.

### **3. Services Provided by Licensor**

1. Data Conversion – The Licensor will convert all existing TIFF document for inclusion in the Document Imaging software module. Licensor will also convert and load all indexing data from the existing software system. Eighty hours of document image conversion and computerized index data conversion is included as part of the Agreement. Licensor warrants that it will justify in writing all hours spent on data conversion that are above eighty hours and that the total of such hours must be reasonable.
2. Website Maintenance - The Licensor will provide Internet hosting of Land Record Indexes and Images for the Licensee. The Licensee will have the capability to upload new index information and images on a daily basis.
3. Telephone Support - The Licensor will provide telephone numbers that can be used as needed by the Licensee for assistance regarding the supported Software Modules and services. Telephone support is available during normal business hours (9:00AM to 5:00PM Monday through Friday). Licensor responds to all telephone support issues based upon the criticality of the issue, with systems that are completely non-functional receiving highest priority. Licensor endeavors, but does not guarantee, to respond to all non-critical issues within one business day.
4. Remote Support –Licensor will provide remote on-line support for the software modules through direct broadband connectivity provided by the Licensee. Remote online support allows the Licensor to perform system troubleshooting and make certain updates or configuration changes more quickly.
5. Additional Services – The Licensor is available to provide additional services as needed at separately negotiated rates that are not included within the terms of this Agreement. These services include, but are not limited to, back-file document scanning, image redaction, and making images of old index books electronically searchable, and back indexing of documents.

### **4. Licensee Responsibilities**

1. Licensee shall allow Licensor to possess a master administrative password allowing access to the Software and Licensee's system as is necessary to complete Licensor's responsibilities under this Agreement.

2. Licensee shall periodically complete a total backup of all databases maintained by the office.
3. Licensee shall permit free and full access, including secure remote access, to the system as is necessary for Licensor to provide service.
4. Licensee shall provide equipment that is dependable and sufficient to meet the needs of the office.
5. Licensee shall provide remote connectivity so that Licensor can securely connect to the network and access individual machines in the Register of Deeds office to provide support.

#### **5. Loaner Equipment**

1. During the installation of software in the office, the Licensor may loan computer equipment to assist in the transition. All equipment provided by the Licensor remains the property of the Licensor. Any loaner equipment provided by the Licensor will be done so free of charge.

#### **6. Software License**

Licensor grants Licensee a non-exclusive, non-transferable license to use up to ten copies of the CCS Workstation Software and Documentation solely for its internal operations at the Location(s) and on the Designated Environment for the term of this Agreement.

Licensor grants Licensee a non-exclusive, non-transferable license to use up to twelve copies of the CCS Search Software and Documentation solely for its internal operations at the Location(s) and on the Designated Environment for the term of this Agreement.

All Software and Documentation remains the property of the Licensor. Licensee agrees to not make unauthorized copies of the Software and Documentation.

Licensee maintains full and irrevocable rights to the data and images maintained within the system. Licensee has the authority to convert this data to a different system at the Register of Deeds sole discretion.

#### **7. Proprietary Rights**

Licensee acknowledges and agrees that the copyright, patent, trade secret, and all other intellectual property rights of whatever nature in the Software or Documentation are and shall remain the property of the Licensor, and nothing in this Agreement should be construed as transferring any aspect of such rights to the Licensee.

#### **8. Confidentiality**

##### **8.1 Confidential Information**

“Confidential Information”, shall mean the Software, Documentation, and terms and conditions of this Agreement. Licensee acknowledges the confidential and proprietary nature of the Confidential Information and agrees that, subject to the North Carolina public records laws, it shall not reveal or disclose any Confidential Information for any purpose to any other person, firm, corporation, or other entity, other than office or county employees with a need to know such confidential information to perform employment responsibilities consistent with Licensee’s rights under this Agreement. Licensee shall safeguard and protect the



Confidential Information from theft, piracy, or unauthorized access in a manner at least consistent with the protections Licensee uses to protect its own most confidential information.

### **8.2 Unauthorized Disclosure**

Licensee shall notify Licensor immediately upon discovery of any prohibited use or disclosure of Confidential Information, or any other breach of confidentiality and shall fully cooperate with the efforts of Licensor to regain possession of the Confidential Information and to prevent the further prohibited use or disclosure of the Confidential Information.

## **9. Warranty**

### **9.1 Operation**

Licensor represents to Licensee that: (1) during the Agreement Period, the Software shall operate without any Errors; and (2) upon notification to Licensor during the Agreement Period of any errors, Licensor will, during its normal business hours and at no cost to Licensee, use reasonable efforts to correct such Errors which are reproducible and verifiable by Licensor

### **9.2 Correction**

In the event that Licensee notifies Licensor of an Error during the Agreement Period, Licensor's sole liability, and Licensee's sole remedy, will be Licensor's use of reasonable efforts to correct such Errors or, in Licensor's sole discretion, to refund a portion of the prepaid Price applicable to the portion of the Software which is defective.

## **10. Price**

For the Software Licenses and Services outlined in this Agreement, Licensee agrees to pay Licensor an annual maintenance fee of \$30,000 and no cents. This annual fee will not increase for the term of this agreement. The maintenance cost is inclusive of software licensing, system implementation, initial training, Internet system configuration, and software maintenance.

## **11. Optional Additional Services**

### **11.1 Customization and Extensive Data Conversion**

Additional time allotments for software customization are available on a time and materials basis of \$125 per hour.

## **12. Term and Termination of Agreement**

### **12.1 Termination and Remedy**

Licensee may terminate the Agreement without prejudice to any other remedy Licensee may have, in the event of any material breach of this Agreement which is not remedied within thirty days of Licensee's notice to Licensor of the breach and Licensee's intent to terminate the License. Termination shall not relieve Licensee's obligation to pay all amounts that are already accrued and owing or which Licensee has agreed to pay.

### **12.2 Breach**

The Licensor may terminate this Agreement, without prejudice to any other remedy Licensor may have, immediately without further obligation to Licensee, in the event of any breach by Licensee, which cannot be remedied within thirty days of Licensor's notice to Licensee of the breach and Licensor's intent to terminate the License.

### **12.3 Cessation of Use**

Upon Termination of this Agreement, Licensee will cease using the Software and Documentation and return all copies of the Software, Documentation, and all other Confidential Information in its possession or destroy all copies of such materials residing in computer memory Licensor shall be entitled to enter the Location(s) to repossess any Software, Documentation, and any other Confidential Information during normal business hours. Licensee shall, within ten days from the effective date of termination, certify in writing that all copies of the Software and Documentation have been returned, deleted, and destroyed.

### **12.4 Non-Appropriation**

Licensor acknowledges that Licensee is a governmental entity, and the contract validity is based upon the availability of public funding under the authority of its statutory mandate.

In the event that public funds are unavailable and not appropriated for the performance of Licensee's obligations under this contract, then this contract shall automatically expire without penalty to Licensee thirty (30) days after written notice to Licensor of the unavailability and non-appropriation of public funds. It is expressly agreed that Licensee shall not activate this non-appropriation provision for its convenience or to circumvent the requirements of this contract, but only as an emergency fiscal measure during a substantial fiscal crisis, which affects generally its governmental operations.

In the event of a change in the Licensee's statutory authority, mandate and mandated functions, by state and federal legislative or regulatory action, which adversely affects Licensee's authority to continue its obligations under this contract, then this contract shall automatically terminate without penalty to Licensee upon written notice to Licensor of such limitation or change in Licensee's legal authority

## **14. Validity**

If any part of this Agreement is held to be illegal or unenforceable, the validity or enforceability of the remainder of this Agreement shall not be affected.

**15. Survival**

Sections 6, 7, and 8 shall survive the termination of this Agreement for any reason.

**16. Entire Agreement**

This Agreement and its schedules and Addendums comprise the entire Agreement between the parties for licensing and support and is not subject to change or modification except by written Agreement signed by both parties.

LICENSOR:

\_\_\_\_\_  
Signature

\_\_\_\_\_  
Name

\_\_\_\_\_  
Title

\_\_\_\_\_  
Date

LICENSEE:

\_\_\_\_\_  
Signature

\_\_\_\_\_  
Name

\_\_\_\_\_  
Title

\_\_\_\_\_  
Date

**"This instrument has been preaudited in the manner required by the Local Government Budget and Fiscal Control Act."**

*Sally Detosoe* 04/15/2019



*Assistant Medical Director Agreement*

**Description**

Enclosed is an agreement with the Brody School of Medicine at East Carolina University for the institution to provide services as the Assistant Medical Director for the County's Emergency Medical Services (EMS) system and staff.

**Board Action Requested**

Approval

**Item Presenter**

Robert Outten, County Manager



## ASSISTANT MEDICAL DIRECTOR AGREEMENT

THIS ASSISTANT MEDICAL DIRECTOR AGREEMENT (“Agreement”) is made and entered into by and between Dare County (the “County”) and East Carolina University through its Brody School of Medicine (the “University”), and is effective as of the date of last signature below (“Effective Date”). County and University are sometimes collectively referred to herein as “Parties” or individually as a “Party.”

### WITNESSETH

WHEREAS, the County provides emergency medical services to the residents of Dare County, North Carolina; and

WHEREAS, the County desires to engage University to provide a qualified physician who is licensed in the state of North Carolina and who is trained and specializes in emergency medicine to provide services as the Assistant Medical Director for the County’s Emergency Medical Services (EMS) System and Staff; and

WHEREAS, the University wishes to provide these services for the County on the terms and subject to the provisions set forth in this Agreement.

NOW, THEREFORE, for and in consideration of the mutual covenants and considerations set forth below and other valuable consideration, the receipt and sufficiency of which are hereby acknowledged, the Parties agree as follows:

1. DUTIES OF UNIVERSITY. The University shall have the following duties and responsibilities under this Agreement:
  - a. The University, through its Chair of its Department of Emergency Medicine, in consultation with the County, shall appoint a physician to serve as assistant medical director (“Assistant Medical Director”) for the County’s EMS System. The University shall cause the Assistant Medical Director to, and the Assistant Medical Director shall perform his or her duties under this Agreement for approximately fifteen (15) hours per month. The approximate hours set forth in this Section are an estimate, but shall not exceed one hundred fifty (150) hours per year. Otherwise, the Assistant Medical Director shall be able to engage in other activities for the University for the remaining percent of his or her time that is unrelated to his or her Assistant Medical Director duties.
  - b. As Assistant Medical Director, the University physician shall:
    - i. Assist the County’s Medical Director with acts and duties as assigned and needed;
    - ii. Assist with oversight of the initial certification and recertification training programs of the County’s EMS and First Responder personnel;



- iii. Advise the County's Medical Director, EMS and First Responder personnel of medically related problems encountered in the field;
- iv. Assist with liaison activities between the County and the Medical Staff of hospitals to which EMS patients are transported;
- v. Assist with development, review and periodically update medical treatment protocols in conjunction with the County's EMS Director (the "EMS Director") and Medical Director;
- vi. Advise the Medical Director and EMS Director as to disaster planning, and interactions between the EMS and Emergency Communications concerning medically related problems;
- vii. Assist in the implementation of a disaster plan for the County;
- viii. Maintain such credentials and meet any and all requirements set forth by the North Carolina College of Emergency Physicians for Medical Directors of an EMS system; and
- ix. Perform such other acts and duties as needed to fulfill the duties of an EMS Medical Director as set forth by the North Carolina Office of Emergency Medical Services, including the duties and responsibilities listed for a medical director as enumerated in the rule located at 10A N.C.A.C. 13P.0403 (Responsibilities of the Medical Director for EMS System Oversight) or its successor for so long as either is in effect.

c. In connection with the Assistant Medical Director services provided under this Agreement, the Assistant Medical Director shall maintain a monthly log recording the effort devoted (Exhibit A). A copy of the Assistant Medical Director's log shall be submitted to the County upon request.

2. DUTIES OF COUNTY. The County shall have the following duties and responsibilities under this Agreement:

a. Provide sufficient personnel, staff, space, facilities, and supplies necessary for the provision of Assistant Medical Director services under this Agreement.

3. COMPENSATION. During the Term of this Agreement, the County agrees to compensate University by paying the University the annual amount of Fifteen Thousand Dollars (\$15,000) for the services provided by the University under this Agreement. Such amount shall be paid in equal quarterly installments of Three Thousand Seven Hundred Fifty Dollars (\$3,750) to be paid on or before the last day of each quarter. In the event any Term of this Agreement is for less than a calendar year, compensation in this Section shall be prorated. The Parties acknowledge and agree that compensation provided under this Agreement is commercially reasonable, does not exceed fair market value, and does not take into account the volume or value of any referrals or other business generated between the Parties. The Parties further acknowledge and agree that the services furnished pursuant

to this Agreement do not involve the counseling or promotion of a business arrangement or other activity that violates any state or federal law.

4. TERM. The initial term of this Agreement (“Initial Term”) shall commence as of the date of last signature below and shall end on June 30, 2019, unless sooner terminated as hereinafter provided. After the Initial Term of this Agreement, the Agreement will renew automatically for additional one (1)-year terms (each, a “Renewal Term”), unless otherwise terminated as provided herein. The Initial Term and any Renewal Term are collectively referred to herein as “Term.”
5. TERMINATION. In addition to other termination provisions herein, either Party shall have the right to terminate this Agreement at any time, with or without cause, by providing thirty (30) days’ written notice to the other Party of its intent to terminate. In addition, all terms and conditions of this Agreement shall automatically terminate if funds cease to be available to compensate University for the services to be furnished under this Agreement. Upon termination for any reason, University shall be compensated by County for all services furnished prior to the date of termination.
6. RELATIONSHIP OF PARTIES. The University’s relationship to the County is that of an independent contractor, and under no circumstances shall this Agreement be construed, deemed, or considered as an employment agreement between the County and the University or their employees or contracted physicians. The University is an independent contractor and is not an agent of the County and is not authorized to act as an agent for the County. The County is not an agent of the University and is not authorized to act as an agent for the University.
7. PAYMENTS AND BENEFITS TO PHYSICIAN. The University is responsible for payments to the physician providing services under this Agreement of his/her salary and other benefits provided to employees or contractors of the University in accord with the University’s standard policies. The University shall also be responsible for all applicable taxes relating to the physician as its employee.
8. INSURANCE.
  - a. University shall maintain Workers’ Compensation insurance as required by North Carolina law covering its employees who provide services under this Agreement. University also agrees to procure and maintain or cause to be procured and maintained medical malpractice liability insurance covering claims, causes of actions, actions, losses, liabilities, damages, and expenses arising out of, caused by or otherwise resulting from the negligence or otherwise wrongful acts or omissions of the University’s employees while each is engaged in medical professional services pursuant to this Agreement. The limits of liability of said insurance shall be at least one million dollars (\$1,000,000.00) per occurrence and three million

dollars (\$3,000,000.00) per aggregate generally, and with respect to each covered physician.

- b. The County shall maintain Workers' Compensation insurance as required by North Carolina law covering its employees. To the extent that the County maintains medical director insurance covering physicians providing administrative duties on behalf of the County, said coverage will be extended to University's physician providing administrative duties on behalf of the County under this Agreement. Provided, however, nothing in this Agreement or Section is intended to provide, nor shall it be construed to provide, insurance coverage to the University or the University's physician by the County for clinical duties and/or patient care and treatment. In addition, nothing in this Agreement or Section is intended to require the County to provide Workers' Compensation insurance for the University's physician, which is the responsibility of the University as indicated above in Subpart (a) of this Section 8.

9. PHYSICIAN-PATIENT RELATIONSHIP. This Agreement shall not be construed to allow the County to control or any way interfere with the physician-patient relationship between physicians employed by or under contract with University and patients receiving services from such physicians. Neither the County nor the University shall control or direct the professional judgment of the University's physicians, and such professional judgment rests solely with the physicians.
10. HOLD HARMLESS. The University will be responsible for the conduct of its officers and employees arising out of the performance of this Agreement to the extent permitted and limited by the laws of North Carolina, including the North Carolina Tort Claims Act, the Defense of State Employees Act, and the Excess Liability Policy administered through the North Carolina Department of Insurance, subject to the availability of appropriations and in proportion to and to the extent that such liability for damages is caused by or results from the acts of University, its officers or employees. As to the University, the County on its behalf accepts responsibility for any and all claims, losses, liabilities, demands, damages, or any other financial demands that may be alleged or realized due to acts of nonfeasance, malfeasance, misfeasance, or negligence committed by itself or its agents, employees, or independent contractors (other than University) while in the performance of their duties or assignments under this Agreement.
11. NO REQUIREMENT TO REFER. The Parties acknowledge that none of the benefits granted to either Party hereunder are conditioned on any requirement that either Party or their employees or agents make referrals to, be in a position to make or influence referrals to, or otherwise generate business for, the other.
12. FRAUD AND ABUSE. The Parties enter into this Agreement with the intent of conducting their relationship in full compliance with applicable state, local, and federal law including



the Medicare/Medicaid Anti-Fraud and Abuse Amendments. Notwithstanding any unanticipated effect of any of the provisions herein, neither Party will intentionally conduct itself under the terms of this Agreement in a manner to constitute a violation of the Medicare/Medicaid fraud and abuse provisions. Further, if legislation is passed, the effect of which would be to hinder either Party's ability to obtain reimbursement from Medicare/Medicaid, or if this Agreement becomes illegal under any subsequent law or regulation, this Agreement shall terminate immediately upon written notice by one Party to the other Party.

13. DEBARMENT. By signing this Agreement, each Party hereby represents and warrants the following: (1) that it has not been debarred, excluded, suspended or otherwise determined to be ineligible to participate in federal health care programs (collectively, "Debarment" or "Debarred," as applicable); (2) no basis for Debarment exists; and (3) it agrees to immediately notify the other Party in the event that it (a) receives notice of action or threat of action with respect to its Debarment during the Term of this Agreement; or (b) becomes Debarred. Upon receipt of such notice by a Party, this Agreement shall automatically terminate without further action or notice.
14. OBRA COMPLIANCE. It is understood that pursuant to Section 952 of Public Law 96-499, as a condition for reimbursement for costs incurred under this Agreement, each Party hereby agrees, that they will retain, and make available upon request of the Secretary of the Department of Health and Human Services or the Comptroller General of the United States, or any of their duly authorized representatives, all books, documents and records necessary to verify the nature and extent of the costs of the services provided under this contract, and that such records will be retained and held available by said Party for such inspection until the expiration of four (4) years after the services are furnished, and it will obtain a similar agreement from any subcontractor it engages to perform on its behalf.
15. DEFICIT REDUCTION ACT. To the extent it is required by 42 U.S.C. § 1396a(a)(68), as it relates to the provision of services under this Agreement, each Party adopts and acknowledges having received written policies of the other Party regarding compliance with the federal False Claims Act, 31 U.S.C. §§ 3729-3733, administrative remedies for false claims and statements, 31 U.S.C. Chapter 38, state laws pertaining to civil or criminal penalties for false claims and statements, and whistleblower protections under such federal and state false claims laws, as well as detailed information regarding the other Party's policies and procedures for detecting and preventing fraud, waste, and abuse.
16. ACCESS TO PERSONS AND RECORDS. North Carolina's State Auditor and University's internal auditor shall be provided access to persons and records that are generated as a result of, or are related to, this Agreement for the purposes of verifying accounts and data affecting fees or performance in accordance with N.C. General Statutes § 147-64.7 and 143-49(9)..

17. NOTICES. Any notice required or allowed to be given hereunder shall be deemed to have been given when personally delivered, or if mailed, seventy-two (72) hours after deposit of the same in the United States Mail, postage prepaid, Registered or Certified, with Return Receipt Requested and properly addressed to the Parties hereto at the respective addresses set forth below, or at such other addresses as they shall specify by written notice delivered in accordance herewith:

Notices shall be sent to University at:

Brody School of Medicine of East Carolina University  
Attn: Executive Director of ECU Physicians  
600 Moye Blvd.  
Greenville, NC 27834

Notices shall be sent to County at:

Dare County Emergency Medical Services  
Attn: Chief Jennie Collins  
P.O. Box 1000  
Manteo, NC 27954

18. RECORDS. The University, its officers, employees and representatives, including University's physician providing services under this Agreement, shall keep confidential all medical and related records/health information regarding the County's patients and shall comply with all federal and state laws applicable to said records and health care information. The County shall be responsible for maintaining all medical records relating to services provided to the County's patients in a confidential manner consistent with applicable federal and state law. At any time during the Term of this Agreement and after termination, University may copy and otherwise have access to such medical records.
19. HIPAA. It is the intent of the Parties to comply with all applicable provisions of the Health Insurance Portability and Accountability Act of 1996, now codified at Title XI, Part C of the Social Security Act, the Health Information Technology for Economic and Clinical Health Act, and all regulations promulgated thereunder (collectively, "HIPAA"), as they may change from time to time. The Parties acknowledge their independent status as "covered entities" under HIPAA and specifically agree to carry out the provisions of this Agreement consistently with applicable HIPAA requirements.
20. RECORD KEEPING. Subject to other provisions in this Agreement, and applicable state and federal law, the County and the University shall provide each other with all documents, reports and other records as are necessary to assure that each Party shall have fiscal information to carry out all of the provisions of this Agreement.

21. GOVERNING LAW. This Agreement is made and entered into in the State of North Carolina and shall be governed and construed in accordance with the laws of North Carolina.
22. ENTIRE AGREEMENT. This Agreement contains the entire agreement of the Parties concerning the subject matter described herein and there are no other promises or conditions in any other agreement whether oral or written concerning the subject matter described herein. This Agreement supersedes any prior written or oral agreements between the Parties concerning the subject matter described herein. This Agreement may not be modified except by a written amendment properly approved and executed by duly authorized Parties.
23. ASSIGNABILITY. This Agreement is personal to each of the Parties hereto, and neither Party may assign nor delegate any of its rights or obligations without first obtaining the written consent of the other Party. Any purported assignment without prior written consent from the other Party shall be null and void. Notwithstanding the foregoing, University may, in its sole discretion, assign this contract to an Associated Entity of the University, specifically including VECU Medical Group, Inc., without approval of County.
24. NO THIRD PARTY BENEFICIARIES. This Agreement shall be binding upon and inure to the benefit of the Parties hereto, their successors and permitted assigns. Nothing in this Agreement is intended, nor shall be deemed, to confer any benefits on any third party, including, without limitation any patients of the County, nor shall such person or entity have any right to seek, enforce or recover any right or remedy with respect hereto.
25. SEVERABILITY. If any provision of this Agreement shall be held to be invalid or unenforceable for any reason, the remaining provisions shall continue to be valid and enforceable. If a court finds that any provision of this Agreement is invalid or unenforceable, but that by limiting such provision it would become valid and enforceable, then such provision shall be deemed to be written, construed, and enforced as so limited.
26. WAIVER OF CONTRACTUAL RIGHT. The failure of either Party to enforce any provision of this Agreement shall not be construed as a waiver or limitation of that Party's right to subsequently enforce and compel strict compliance with every provision of this Agreement.
27. HEADINGS. The headings to the various sections of this Agreement have been inserted for convenience only and shall not modify, define, limit or expand express provisions of this Agreement.
28. BINDING AUTHORITY. Each Party to this Agreement represents to the other that it has the full right, power and authority to enter and perform this Agreement in accordance with



all of the terms and conditions thereof, and that the execution and delivery of this Agreement has been made by authorized representatives of the Parties.

29. COUNTERPARTS. This Agreement may be executed simultaneously in one or more counterparts, each of which shall be deemed an original but all of which together shall constitute one and the same instrument.
30. SIGNATURES. As it is applicable to this Agreement, the Parties agree to and adopt the terms and conditions of the Uniform Electronic Transactions Act (the "Act"), as adopted in North Carolina General Statutes Chapter 66, including but not limited to the provisions governing electronic signatures. As such, this Agreement is "signed" if it includes a digital signature, symbol, and/or action that is adopted or performed by either Party or Party's Electronic Agent (as defined in the Act) with the present intent to authenticate or manifest assent to the Agreement.

**[Signatures on Next Page]**



IN WITNESS WHEREOF, the Parties have executed this Agreement in duplicate originals, one of which is to be retained by the County, and one of which is to be retained by the University, effective as of the date of last signature below.

FOR AND ON BEHALF OF \_\_\_\_\_ COUNTY

\_\_\_\_\_  
Print Name: \_\_\_\_\_

Title: \_\_\_\_\_

Date: \_\_\_\_\_

FOR AND ON BEHALF OF THE  
BRODY SCHOOL OF MEDICINE AT EAST CAROLINA UNIVERSITY

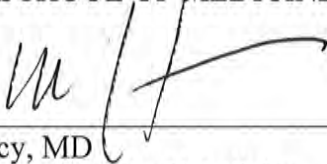

\_\_\_\_\_  
Mark Stacy, MD  
Dean, Brody School of Medicine  
Senior Associate Vice Chancellor for Medical Affairs

Date: 1/10/19



\_\_\_\_\_  
Theodore R. Delbridge, MD, MPH  
Chair, Department of Emergency Medicine

Date: 1/01/2019

This instrument has been preaudited in the manner required by the Local Government Budget and Fiscal Control Act.

\_\_\_\_\_  
Print Name: \_\_\_\_\_

Title: \_\_\_\_\_

EXHIBIT A

DARE COUNTY EMS ASSISTANT MEDICAL DIRECTOR LOG

Name: \_\_\_\_\_

Month/Year: \_\_\_\_\_

Administrative Services for County

Dates

#Hours

Oversee training programs

\_\_\_\_\_

\_\_\_\_\_

Advise on medical problems

\_\_\_\_\_

\_\_\_\_\_

Liaison Activities

\_\_\_\_\_

\_\_\_\_\_

Develop/Review/Update Medical  
Treatment Protocols

\_\_\_\_\_

\_\_\_\_\_

Advise Director on disaster planning, etc.

\_\_\_\_\_

\_\_\_\_\_

Assist in the implementation of disaster plan

\_\_\_\_\_

\_\_\_\_\_

Meetings

\_\_\_\_\_

\_\_\_\_\_

Other:

\_\_\_\_\_

\_\_\_\_\_

\_\_\_\_\_

\_\_\_\_\_

\_\_\_\_\_

\_\_\_\_\_

\_\_\_\_\_

\_\_\_\_\_

\_\_\_\_\_

\_\_\_\_\_

\_\_\_\_\_

\_\_\_\_\_

\_\_\_\_\_

\_\_\_\_\_

\_\_\_\_\_

\_\_\_\_\_

\_\_\_\_\_

\_\_\_\_\_

Total hours: \_\_\_\_\_



*Audit Contract for Fiscal Year 2019*

**Description**

As recommended by the Audit Committee, the Board approved a 4 year renewal for audit services with Potter & Company beginning with fiscal year 2018. Attached is the FY2019 audit contract at \$66,500 with the 2% annual increase agreed upon with the renewal.

**Board Action Requested**

Authorize the Chairman and Commissioner Ross, as Chairman of the Audit Committee, to execute the contract.

**Item Presenter**

David Clawson, Finance Director

The of and	Governing Board Dare County, North Carolina
	Primary Government Unit Dare County, North Carolina
	Discretely Presented Component Unit (DPCU) (if applicable)

*Primary Government Unit, together with DPCU (if applicable), hereinafter referred to as Governmental Unit(s)*

and	Auditor Name Potter & Company, P.A
	Auditor Address 106 Welton Way, Mooresville, North Carolina

*Hereinafter referred to as Auditor*

for	Fiscal Year Ending	Audit Report Due Date
	06/30/19	10/31/19

*Must be within four months of FYE*

hereby agree as follows:

1. The Auditor shall audit all statements and disclosures required by U.S. generally accepted auditing standards (GAAS) and additional required legal statements and disclosures of all funds and/or divisions of the Governmental Unit(s). The non-major combining, and individual fund statements and schedules shall be subjected to the auditing procedures applied in the audit of the basic financial statements and an opinion shall be rendered in relation to (as applicable) the governmental activities, the business-type activities, the aggregate DPCUs, each major governmental and enterprise fund, and the aggregate remaining fund information (non-major government and enterprise funds, the internal service fund type, and the fiduciary fund types).

2. At a minimum, the Auditor shall conduct his/her audit and render his/her report in accordance with GAAS. The Auditor shall perform the audit in accordance with *Government Auditing Standards* if required by the State Single Audit Implementation Act, as codified in G.S. 159-34. If required by OMB *Uniform Administration Requirements, Cost Principles, and Audit Requirements for Federal Awards (Uniform Guidance)* and the State Single Audit Implementation Act, the Auditor shall perform a Single Audit. This audit and all associated audit documentation may be subject to review by Federal and State agencies in accordance with Federal and State laws, including the staffs of the Office of State Auditor (OSA) and the Local Government Commission (LGC). If the audit requires a federal single audit performed under the requirements found in Subpart F of the Uniform Guidance (§200.501), it is recommended that the Auditor and Governmental Unit(s) jointly agree, in advance of the execution of this contract, which party is responsible for submission of the audit and the accompanying data collection form to the Federal Audit Clearinghouse as required under the Uniform Guidance (§200.512).

If the audit and Auditor communication are found in this review to be substandard, the results of the review may be forwarded to the North Carolina State Board of CPA Examiners (NC State Board).

**County and Multi-County Health Departments:** The Office of State Auditor will require Auditors of these Governmental Units to perform agreed upon procedures (AUPs) on eligibility determination on certain programs. Both Auditor and Governmental Unit agree that Auditor shall complete and report on these AUPs on

eligibility determination as required by OSA and in accordance with the instructions and timeline provided by OSA.

3. If an entity is determined to be a component of another government as defined by the group audit standards, the entity's auditor shall make a good faith effort to comply in a timely manner with the requests of the group auditor in accordance with AU-6 §600.41 - §600.42.

4. This contract contemplates an unmodified opinion being rendered. If during the process of conducting the audit, the Auditor determines that it will not be possible to render an unmodified opinion on the financial statements of the unit, the Auditor shall contact the LGC staff to discuss the circumstances leading to that conclusion as soon as is practical and before the final report is issued. The audit shall include such tests of the accounting records and such other auditing procedures as are considered by the Auditor to be necessary in the circumstances. Any limitations or restrictions in scope which would lead to a qualification should be fully explained in an attachment to this contract.

5. If this audit engagement is subject to the standards for audit as defined in *Government Auditing Standards*, 2011 revisions, issued by the Comptroller General of the United States, then by accepting this engagement, the Auditor warrants that he/she has met the requirements for a peer review and continuing education as specified in *Government Auditing Standards*. The Auditor agrees to provide a copy of the most recent peer review report to the Governmental Unit(s) and the Secretary of the LGC prior to the execution of an audit contract. Subsequent submissions of the report are required only upon report expiration or upon auditor's receipt of an updated peer review report. If the audit firm received a peer review rating other than pass, the Auditor shall not contract with the Governmental Unit(s) without first contacting the Secretary of the LGC for a peer review analysis that may result in additional contractual requirements.

If the audit engagement is not subject to *Government Accounting Standards* or if financial statements are not prepared in accordance with U.S. generally accepted accounting principles (GAAP) and fail to include all disclosures required by GAAP, the Auditor shall provide an explanation as to why in an attachment to this contract or in an amendment.

6. It is agreed that time is of the essence in this contract. All audits are to be performed and the report of audit submitted to LGC staff within four months of fiscal year end. If it becomes necessary to amend this due date or the audit fee, an amended contract along with a written explanation of the delay shall be submitted to the Secretary of the LGC for approval.

7. It is agreed that GAAS include a review of the Governmental Unit's (Units') systems of internal control and accounting as same relate to accountability of funds and adherence to budget and law requirements applicable thereto; that the Auditor shall make a written report, which may or may not be a part of the written report of audit, to the Governing Board setting forth his/her findings, together with his recommendations for improvement. That written report shall include all matters defined as "significant deficiencies and material weaknesses" in AU-C 265 of the *AICPA Professional Standards (Clarified)*. The Auditor shall file a copy of that report with the Secretary of the LGC.

8. All local government and public authority contracts for audit or audit-related work require the approval of the Secretary of the LGC. This includes annual or special audits, agreed upon procedures related to internal controls, bookkeeping or other assistance necessary to prepare the Governmental Unit's (Units') records for audit, financial statement preparation, any finance-related investigations, or any other audit-related work in the State of North Carolina. Invoices for services rendered under these contracts shall not be paid by the Governmental Unit(s) until the invoice has been approved by the Secretary of the LGC. (This also includes any progress billings.) [G.S. 159-34 and 115C-447] All invoices for Audit work shall be submitted in PDF format to the Secretary of the LGC for approval. The invoice marked 'approved' with approval date shall be returned to



the Auditor to present to the Governmental Unit(s) for payment. Approval is not required on contracts and invoices for system improvements and similar services of a non-auditing nature.

9. In consideration of the satisfactory performance of the provisions of this contract, the Governmental Unit(s) shall pay to the Auditor, upon approval by the Secretary of the LGC, the fee, which includes any costs the Auditor may incur from work paper or peer reviews or any other quality assurance program required by third parties (federal and state grantor and oversight agencies or other organizations) as required under the Federal and State Single Audit Acts. This does not include fees for any pre-issuance reviews that may be required by the NC Association of CPAs (NCACPA) Peer Review Committee or NC State Board of CPA Examiners (see Item 12).

10. If the Governmental Unit(s) has/have outstanding revenue bonds, the Auditor shall submit to LGC staff, either in the notes to the audited financial statements or as a separate report, a calculation demonstrating compliance with the revenue bond rate covenant. Additionally, the Auditor shall submit to LGC staff simultaneously with the Governmental Unit's (Units') audited financial statements any other bond compliance statements or additional reports required by the authorizing bond documents, unless otherwise specified in the bond documents.

11. After completing the audit, the Auditor shall submit to the Governing Board a written report of audit. This report shall include, but not be limited to, the following information: (a) Management's Discussion and Analysis, (b) the financial statements and notes of the Governmental Unit(s) and all of its component units prepared in accordance with GAAP, (c) supplementary information requested by the Governmental Unit(s) or required for full disclosure under the law, and (d) the Auditor's opinion on the material presented. The Auditor shall furnish the required number of copies of the report of audit to the Governing Board upon completion.

12. If the audit firm is required by the NC State Board, the NCACPA Peer Review Committee, or the Secretary of the LGC to have a pre-issuance review of its audit work, there shall be a statement in the engagement letter indicating the pre-issuance review requirement. There also shall be a statement that the Governmental Unit(s) shall not be billed for the pre-issuance review. The pre-issuance review shall be performed prior to the completed audit being submitted to LGC Staff. The pre-issuance review report shall accompany the audit report upon submission to LGC Staff.

13. The Auditor shall submit the report of audit in PDF format to LGC Staff when (or prior to) submitting the final invoice for services rendered. The report of audit, as filed with the Secretary of the LGC, becomes a matter of public record for inspection, review and copy in the offices of the LGC by any interested parties. Any subsequent revisions to these reports shall be sent to the Secretary of the LGC along with an Audit Report Reissued Form (available on the Department of State Treasurer website). These audited financial statements, excluding the Auditors' opinion, may be used in the preparation of official statements for debt offerings by municipal bond rating services to fulfill secondary market disclosure requirements of the Securities and Exchange Commission and for other lawful purposes of the Governmental Unit(s) without requiring consent of the Auditor. If the LGC Staff determines that corrections need to be made to the Governmental Unit's (Units') financial statements, those corrections shall be provided within three business days of notification unless another deadline is agreed to by LGC staff.

If the OSA designates certain programs to be audited as major programs, as discussed in Item 2, a turnaround document and a representation letter addressed to the OSA shall be submitted to LGC Staff.

14. Should circumstances disclosed by the audit call for a more detailed investigation by the Auditor than necessary under ordinary circumstances, the Auditor shall inform the Governing Board in writing of the need for such additional investigation and the additional compensation required therefore. Upon approval by the



Secretary of the LGC, this contract may be modified or amended to include the increased time, compensation, or both as may be agreed upon by the Governing Board and the Auditor.

15. If an approved contract needs to be modified or amended for any reason, the change shall be made in writing, on the Amended LGC-205 contract form and pre-audited if the change includes a change in audit fee (pre-audit requirement does not apply to charter schools). This amended contract shall be completed in full, including a written explanation of the change, signed and dated by all original parties to the contract. It shall then be submitted to the Secretary of the LGC for approval. No change to the audit contract shall be effective unless approved by the Secretary of the LGC, the Governing Board, and the Auditor.
16. A copy of the engagement letter, issued by the Auditor and signed by both the Auditor and the Governmental Unit(s), shall be attached to this contract, and shall be incorporated by reference as if fully set forth herein as part of this contract. In case of conflict between the terms of the engagement letter and the terms of this contract, the terms of this contract shall take precedence. Engagement letter terms that conflict with the contract are deemed to be void unless the conflicting terms of this contract are specifically deleted in Item 26 of this contract. Engagement letters containing indemnification clauses shall not be accepted by LGC Staff.
17. Special provisions should be limited. Please list any special provisions in an attachment.
18. A separate contract should not be made for each division to be audited or report to be submitted. If a DPCU is subject to the audit requirements detailed in the Local Government Budget and Fiscal Control Act and a separate audit report is issued, a separate audit contract is required. If a separate report is not to be issued and the DPCU is included in the primary government audit, the DPCU shall be named along with the parent government on this audit contract. DPCU Board approval date, signatures from the DPCU Board chairman and finance officer also shall be included on this contract.
19. The contract shall be executed, pre-audited (pre-audit requirement does not apply to charter schools), and physically signed by all parties including Governmental Unit(s) and the Auditor, then submitted in PDF format to the Secretary of the LGC.
20. The contract is not valid until it is approved by the Secretary of the LGC. The staff of the LGC shall notify the Governmental Unit and Auditor of contract approval by email. The audit should not be started before the contract is approved.
21. Retention of Client Records: Auditors are subject to the NC State Board of CPA Examiners' Retention of Client Records Rule 21 NCAC 08N .0305 as it relates to the provision of audit and other attest services, as well as non-attest services. Clients and former clients should be familiar with the requirements of this rule prior to requesting the return of records.
22. This contract may be terminated at any time by mutual consent and agreement of the Governmental Unit(s) and the Auditor, provided that (a) the consent to terminate is in writing and signed by both parties, (b) the parties have agreed on the fee amount which shall be paid to the Auditor (if applicable), and (c) no termination shall be effective until approved in writing by the Secretary of the LGC.
23. The Governmental Unit's (Units') failure or forbearance to enforce, or waiver of, any right or an event of breach or default on one occasion or instance shall not constitute the waiver of such right, breach or default on any subsequent occasion or instance.
24. There are no other agreements between the parties hereto and no other agreements relative hereto that shall be enforceable unless entered into in accordance with the procedure set out herein and approved by the Secretary of the LGC.

25. E-Verify. Auditor shall comply with the requirements of NCGS Chapter 64 Article 2. Further, if Auditor utilizes any subcontractor(s), Auditor shall require such subcontractor(s) to comply with the requirements of NCGS Chapter 64, Article 2.

26. All of the above paragraphs are understood and shall apply to this contract, except the following numbered paragraphs shall be deleted (See Item 16 for clarification).

27. The process for submitting contracts, audit reports and invoices is subject to change. Auditors and units should use the submission process and instructions in effect at the time of submission. Refer to the N.C. Department of State Treasurer website at <https://www.nctreasurer.com/slg/Pages/Audit-Forms-and-Resources.aspx>.

28. All communications regarding audit contract requests for modification or official approvals will be sent to the email addresses provided on the signature pages that follow.

**FEEES FOR AUDIT SERVICES**

For all non-attest services, the Auditor shall adhere to the independence rules of the AICPA Professional Code of Conduct and *Governmental Auditing Standards* (as applicable). Bookkeeping and other non-attest services necessary to perform the audit shall be included under this contract. However, bookkeeping assistance shall be limited to the extent that the Auditor is not auditing his or her own work or making management decisions. The Governmental Unit shall designate an individual with the suitable skills, knowledge, and/or experience necessary to oversee the services and accept responsibility for the results of the services. Financial statement preparation assistance shall be deemed a "significant threat" requiring the Auditor to apply safeguards sufficient to reduce the threat to an acceptable level. The Auditor shall maintain written documentation of his or her compliance with these standards in the audit work papers.

Fees may not be included in this contract for work performed on Annual Financial Information Reports (AFIRs), Form 990s, or other services not associated with audit fees and costs. Such fees may be included in the engagement letter, but may not be included in this contract or in any invoices requiring approval of the LGC. See Items 8, 9, and 12 for details on other allowable and excluded fees.

Prior to submission of the completed audited financial report, applicable compliance reports and amended contract (if required) the Auditor may submit invoices for approval for services rendered, not to exceed 75% of the total of the stated fees below. If the current contracted fee is not fixed in total, invoices for services rendered may be approved for up to 75% of the prior year audit fee. Should the 75% cap provided below conflict with the cap calculated by LGC staff based on the prior year audit fee on file with the LGC, the LGC calculation prevails.

**20 NCAC 03 .0505: All invoices for services rendered in an audit engagement as defined in 20 NCAC 3 .0503 shall be submitted to the Commission for approval before any payment is made. Payment before approval is a violation of law.**

**PRIMARY GOVERNMENT FEES**

Primary Government Unit	Dare County, North Carolina
Audit	\$ 64,000
Writing Financial Statements	\$ 2,500
All Other Non-Attest Services	\$ see Engagement Letter attached
75% Cap for Interim Invoice Approval	\$ 49,875.00

**DPCU FEES (if applicable)**

Discretely Presented Component Unit	
Audit	\$
Writing Financial Statements	\$
All Other Non-Attest Services	\$
75% Cap for Interim Invoice Approval	\$

SIGNATURE PAGE

AUDIT FIRM

Audit Firm Potter & Company, P.A	
Authorized Firm Representative (typed or printed) Robert W. Taylor	Signature 
Date 01/02/19	Email Address btaylor@gotopotter.com

GOVERNMENTAL UNIT

Governmental Unit Dare County, North Carolina	
Date Primary Government Unit Governing Board Approved Audit Contract (Ref: G.S. 159-34(a) or G.S. 115C-447(a)) ✓	
Mayor/Chairperson (typed or printed) ✓	Signature ✓
Date ✓	Email Address ✓

Chair of Audit Committee (typed or printed, or "NA") ✓	Signature ✓
Date ✓	Email Address ✓

**GOVERNMENTAL UNIT – PRE-AUDIT CERTIFICATE**  
*(Pre-audit certificate not required for charter schools)*

Required by G.S. 159-28(a1) or G.S. 115C-441(a1)

*This instrument has been pre-audited in the manner required by The Local Government Budget and Fiscal Control Act or by the School Budget and Fiscal Control Act.*

Primary Governmental Unit Finance Officer (typed or printed) ✓	Signature ✓
Date of Pre-Audit Certificate ✓	Email Address ✓

**SIGNATURE PAGE – DPCU  
(complete only if applicable)**

**DISCRETELY PRESENTED COMPONENT UNIT**

DPCU	
Date DPCU Governing Board Approved Audit Contract (Ref: G.S. 159-34(a) or G.S. 115C-447(a))	
DPCU Chairperson (typed or printed)	Signature
Date	Email Address

Chair of Audit Committee (typed or printed, or "NA")	Signature
Date	Email Address

**DPCU – PRE-AUDIT CERTIFICATE**  
*(Pre-audit certificate not required for charter schools)*

Required by G.S. 159-28(a1) or G.S. 115C-441(a1)

*This instrument has been pre-audited in the manner required by The Local Government Budget and Fiscal Control Act or by the School Budget and Fiscal Control Act.*

DPCU Finance Officer (typed or printed)	Signature
Date of Pre-Audit Certificate	Email Address

Remember to print this form, and obtain all required signatures prior to submission.

**PRINT**





**POTTER & COMPANY**  
CERTIFIED PUBLIC ACCOUNTANTS

January 2, 2019

To the Board of Commissioners  
Dare County  
Manteo, North Carolina

We are pleased to confirm our understanding of the services we are to provide for the Dare County, North Carolina for the year ending June 30, 2019. We will audit the financial statements of the governmental activities, the business-type-activities, the aggregate discretely presented component units, each major fund, and the aggregate remaining fund information, which collectively comprise the entity's basic financial statements, of the Dare County, North Carolina, as of and for the year ending June 30, 2019. Accounting standards general accepted in the United States provide for certain required supplementary information (RSI), such as management's discussion and analysis (MD&A), to accompany the Dare County, North Carolina's basic financial statements. Such information, although not a part of the basic financial statements, is required by the Governmental Accounting Standards Board who considers it to be an essential part of financial reporting for placing the basic financial statements in an appropriate operational, economic, or historical context. As part of our engagement, we will apply certain limited procedures to the Dare County, North Carolina's RSI in accordance with auditing standards generally accepted in the United States of America. These limited procedures will consist of inquiries of management regarding the methods of preparing the information and comparing the information for consistency with management's responses to our inquiries, the basic financial statements, and other knowledge we obtained during our audit of the basic financial statements. We will not express an opinion or provide any assurance on the information because the limited procedures do not provide us with sufficient evidence to express an opinion or provide any assurance. The following RSI is required by generally accepted accounting principles and will be subjected to certain limited procedures, but will not be audited:

1. Management's discussion and analysis.
2. Letter of Transmittal.
3. Budgetary comparison schedules.
4. GASB required supplementary pension and OPEB reporting.

We have also been engaged to report on supplementary information other than RSI that accompanies the Dare County, North Carolina's financial statements. We will subject the following supplementary information to the auditing procedures applied in our audit of the financial statements and certain additional procedures, including comparing and reconciling such information directly to the underlying accounting and other records used to prepare the financial statements or the financial statements themselves, and other additional procedures in accordance with auditing standards generally accepted in the United States of America and will provide an opinion on it in relation to the financial statements as a whole:

1. Schedule of expenditures of federal and State awards.
2. Combining and individual fund statements.
3. Statistical data.



## **Audit Objectives**

The objective of our audit is the expression of an opinion as to whether your general purpose financial statements are fairly presented, in all material respects, in conformity with U.S. generally accepted accounting principles and to report on the fairness of the supplementary information when considered in relation to the general purpose financial statements taken as a whole. The objective also includes reporting on:

- Internal control over financial statements and compliance with laws, regulations, and the provisions of contracts or grant agreements, noncompliance with which could have a material effect on the financial statements in accordance with *Government Auditing Standards*.
- Internal control over compliance related to major programs and an opinion (or disclaimer of opinion) on compliance with laws, regulations, and the provisions of contracts or grant agreements that could have a direct and material effect on each major program in accordance with the Single Audit Act Amendments of 1996 and Title 2 U.S. *Code of Federal Regulations* (CFR) Part 200, *Uniform Administrative Requirements, Cost Principles, and Audit Requirements for Federal Awards* (Uniform Guidance).

The *Government Auditing Standards* reports on internal control and compliance will each include a paragraph that states that the purpose of the report is solely to describe (1) the scope of testing of internal control over financial reporting and compliance and the result of that testing and not to provide an opinion on the effectiveness of internal control over financial reporting or on compliance, and (2) that the report is an integral part of an audit performed in accordance with *Government Auditing Standards* in considering internal control over financial reporting and compliance. The Uniform Guidance report on internal control over compliance will include a paragraph that states that the purpose of the report on internal control over compliance is solely to describe the scope of testing of internal control over compliance and the results of that testing based on the requirements of the Uniform Guidance. Both reports will state that the report is not suitable for any other purpose.

Our audit will be conducted in accordance with auditing standards generally accepted in the United States of America; the standards for financial audits contained in *Government Auditing Standards*, issued by the Comptroller General of the United States; the Single Audit Act Amendments of 1996; and the provisions of the Uniform Guidance and will include tests of accounting records, a determination of major program(s) in accordance with Uniform Guidance, and other procedures we consider necessary to enable us to express such an opinion. We will issue written reports upon completion of our Single Audit. Our reports will be addressed the governing Board of Dare County, North Carolina. We cannot provide assurance that unmodified opinions will be expressed. Circumstances may arise in which it is necessary for us to modify our opinions or add emphasis-of-matter paragraphs. If our opinions are other than unmodified, we will fully discuss the reasons with you in advance. If, for any reason, we are unable to complete the audit or are unable to form or have not formed an opinion, we may decline to express an opinion or to issue a report as a result of this engagement

## **Management Responsibilities**

Management is responsible for 1) establishing and maintaining effective internal controls, including internal controls over federal awards, and for evaluating and monitoring ongoing activities, to help ensure that appropriate goals and objectives are met; 2) following laws and regulations; 3) ensuring that there is reasonable assurance that government programs are administered in compliance with compliance requirements; and 4) ensuring that management and financial information is reliable and properly reported. Management is also responsible for implementing systems designed to achieve compliance with applicable laws, regulation, contracts, and grant agreements. You are also responsible for the selection and application of accounting principles; for the preparation and fair presentation of the financial statements; schedule of expenditures of federal awards, and all accompanying

information in conformity with U.S. general accepted accounting principles; and for compliance with applicable laws and regulations (including general statutes) and the provisions of contracts and grant agreements ( including award agreement). Your responsibilities also include identifying significant contractor relationships in which the contractor has responsibility for program compliance and for the accuracy and completeness of that information.

Management is also responsible for making all financial records and related information available to us and for the accuracy and completeness of that information. You are also responsible for providing us with 1) access to all information of which you are aware that is relevant to the preparation and fair presentation of the financial statements, 2) access to personnel, accounts, books, records, supporting documentation, and other information as needed to perform and audit under the Uniform Guidance, 3) additional information that we may request for the purpose of the audit, and 4) unrestricted access to persons within the government from whom we determine it necessary to obtain audit evidence.

Your responsibilities include adjusting the financial statements to correct material misstatements and confirming to us in the management representation letter that the effects of any uncorrected misstatements aggregated by us during the current engagement and pertaining to the latest period presented are immaterial, both individually and in the aggregate, to the financial statements as a whole.

You are responsible for the design and implementation of programs and controls to prevent and detect fraud, and for informing us about all known or suspected fraud or illegal acts affecting the government involving 1) management, 2) employees who have significant roles in internal control, and 3) others where the fraud or illegal acts could have a material effect on the financial statements. Your responsibilities include informing us of your knowledge of any allegation of fraud or suspected fraud affecting the government received in communications from employees, former employees, grantors, regulators, or others. In addition, you are responsible for identifying and ensuring that the entity complies with applicable laws, regulations contracts, agreements, and grants. Additionally, as required by the Uniform Guidance, it is management's responsibility to evaluate and monitor noncompliance with federal statutes, regulations, and the terms and conditions of federal awards; take prompt action when instances of noncompliance are identified including noncompliance identified in audit findings; promptly follow up and take corrective action on report audit findings and to prepare a summary schedule of prior audit findings and a corrective action plan. The summary schedule of prior audit findings should be available for our review.

You are responsible for identifying all federal awards received and understanding and complying with the compliance requirements and for the preparation of the schedule of expenditures of federal awards (including notes and noncash assistance received) in conformity with the Uniform Guidance. You agree to include our report on the schedule of expenditures of federal awards in any document that contains and indicates that we have reported on the schedule of expenditures of federal awards. You also agree to include the audited financial statements with any presentation of the schedule of expenditures of federal awards that includes our report thereon or make the audited financial statements readily available to intended users of the schedule of expenditures of federal awards no later than the date of schedule of expenditures of federal awards is issued with our report thereon. Your responsibilities include acknowledging to us in the written representation letter that a) you are responsible for presentation of the schedule of expenditures of federal awards in accordance with the Uniform Guidance; b) that you believe that schedule of expenditures of federal awards, including its form and content, is fairly presented in accordance with the Uniform Guidance; c) that the methods of measurement or presentation have not changed from those used in the prior period; and d) you have disclosed to us any significant assumptions or interpretations underlying the measurement or presentation of the schedule of expenditures of federal awards.

You are also responsible for the preparation of the other supplementary information, which we have been engaged to report on, in conformity with U. S. generally accepted accounting principles. You agree to include our report on the supplementary information in any document that contains and indicates that we have reported on the supplementary information in any document that contains, and indicates that we have reported on, the supplementary information. You also agree to include the audited financial statements with any presentation of the

supplementary information that includes our report thereon or make the audited financial statements readily available to users of the supplementary information no later than the date the supplementary information is issued with our report thereon. Your responsibilities include acknowledging to us in the written representation letter that s) you are responsible for presentation of the supplementary information in accordance with GAAP; b) that you believe the supplementary information, including its form and content, is fairly presented in accordance with GAAP; c) that the methods of measurement or presentation have not changed from those used in the prior period; and d) you have disclosed to us any significant assumptions or interpretations underlying the measurement or presentation of the supplementary information.

Management is responsible for establishing and maintaining process for tracking the status of audit findings and recommendation. Management is also responsible for identifying for us previous financial audits, attestation engagements, performance audits, or other studies related to the objectives discussed in the Audit Objectives section of the letter. This responsibility includes relaying to us corrective actions taken to address significant finding and recommendations resulting from those audits, attestation engagements, performance audits, or studies. You are also responsible for providing managements' view on our current findings, conclusions, and recommendation, as well as your planned corrective action, for the report, and for the timing and format for providing that information.

You agree to assume all management responsibilities relating to the financial statements, schedule of expenditures of federal awards, and related notes, and any other nonaudit services we provide. You will be required to acknowledge in the management representation letter our assistance with preparation of the financial statements, schedule of expenditures of federal awards, and related notes and that you have reviewed and approved the financial statements, schedule of expenditures of federal awards, and related notes prior to their issuance and have accepted responsibility for them. Further, you agree to oversee the non audit services by designating an individual, preferable from senior management, with suitable skill, knowledge, or experience; evaluate the adequacy and results of those services; and accept responsibility for them.

### **Audit Procedures—General**

An audit includes examining, on a test basis, evidence supporting the amounts and disclosures in the financial statements; therefore, our audit will involve judgment about the number of transactions to be examined and the areas to be tested. We will plan and perform the audit to obtain reasonable rather than absolute assurance about whether the financial statements are free of material misstatement, whether from errors, fraudulent financial reporting, misappropriation of assets, or violations of laws or governmental regulations that are attributable to the entity or to acts by management or employees acting on behalf of the entity. Because the determination of abuse is subjective, *Government Auditing Standards* do not expect auditors to provide reasonable assurance of detecting abuse.

Because of the inherent limitations of an audit, combined with the inherent limitation of internal control, and because we will not perform a detailed examination of all transactions, there is a risk that material misstatements or noncompliance may exist and not be detected by us even though the audit is properly planned and performed in accordance with U.S. generally accepted auditing standards and *Government Auditing Standards*. In addition, an audit is not designed to detect immaterial misstatements or violations of laws or governmental regulations that do not have a direct and material effect on the financial statements or major programs. However, we will inform you of any material errors and any fraudulent financial reporting or misappropriation of assets that comes to our attention. We will also inform you of any violations of laws or governmental regulations that come to our attention, unless clearly inconsequential. We will include such matters in the reports required for a Single Audit. Our responsibility as an auditor is limited to the period covered by our audit and does not extend to matters that might arise during any later periods for which we are not engaged as auditors.



Our procedures will include tests of documentary evidence supporting the transactions recorded in the accounts, and may include tests of the physical existence of inventories, and direct confirmation of receivables and certain other assets and liabilities by correspondence with selected individuals, creditors, and financial institutions. We will request written representations from your attorneys as part of the engagement, and they may bill you for responding to this inquiry. At the conclusion of our audit, we will also require certain written representations from you about your responsibilities for the financial statements; schedule of expenditures of federal awards; federal award programs; compliance with laws, regulations, contracts, and grant agreements; and other responsibilities required by generally accepted auditing standards.

### **Audit Procedures—Internal Controls**

Our audit will include obtaining an understanding of the entity and its environment, including internal control, sufficient to assess the risks of material misstatement of the financial statements to design the nature, timing, and extent of further audit procedures. Tests of controls may be performed to test the effectiveness of certain controls that we consider relevant to preventing and detecting errors and fraud that are material to the general purpose financial statements and to preventing and detecting misstatements resulting from illegal acts and other noncompliance matters that have a direct and material effect on the general purpose financial statements. Tests of controls relative to the general purpose financial statements are required only if control risk is assessed below the maximum level. Our tests, if performed, will be less in scope than would be necessary to render an opinion on internal control and, accordingly, no opinion will be expressed in our report on internal control issued pursuant to *Government Auditing Standards*.

As required by the Uniform Guidance, we will perform tests of controls to evaluate the effectiveness of the design and operation of controls that we consider relevant to preventing or detecting material noncompliance with compliance requirements applicable to each major federal award program. However, our tests will be less in scope than would be necessary to render an opinion on those controls and, accordingly, no opinion will be expressed in our report on internal control issued pursuant to the Uniform Guidance.

An audit is not designated to provide assurance on internal control or to identify significant deficiencies. However, during the audit, we will communicate to management and those charged with governance internal control related matters that are required to be communicated under professional standards, *Government Audit Standards*, and the Uniform Guidance.

### **Audit Procedures—Compliance**

As part of obtaining reasonable assurance about whether the financial statements are free of material misstatement, we will perform tests of the Dare County North Carolina's compliance with applicable laws and regulations and the provisions of contracts and agreements, including grant agreements. However, the objective of those procedures will not be to provide an opinion on overall compliance and we will not express such an opinion in our report on compliance issued pursuant to *Government Auditing Standards*.

The Uniform Guidance requires that we also plan and perform the audit to obtain reasonable assurance about whether the auditee has complied with federal statutes, regulations, and the terms and conditions of federal awards applicable to major programs. Our procedures will consist of the applicable procedures described in the *OMB Compliance Supplement* for the types of compliance requirements that could have a direct and material effect on each of the Dare County, North Carolina's major programs, if any. The purpose of those procedures will be to express an opinion on the Dare County, North Carolina's compliance with requirements applicable to major programs in our report on compliance issued pursuant to the Uniform guidance.

### **Audit Administration, Fees, and Other**

We may from time to time, and depending on the circumstances, use third-party service providers in serving your account. We may share confidential information about you with these service providers, but remain committed to maintaining the confidentiality and security of your information. Accordingly, we maintain internal policies, procedures, and safeguards to protect the confidentiality of your personal information. In addition, we will secure confidentiality agreements with all serviced providers to maintain the confidentiality of your information and we will take reasonable precautions to determine that they have appropriate procedures in place to prevent the unauthorized release of your confidential information to others. In the event that we are unable to secure an appropriate confidentiality agreement, you will be asked to provide your consent prior to the sharing of your confidential information with the third-party service provider. Furthermore, we will remain responsible for the work provided by any such third-party service providers.

We understand that your employees will prepare all cash, accounts receivable, or other confirmations we request and will locate any invoices selected by us for testing.

At the conclusion of the engagement, we will complete the appropriate sections of and sign the Data Collection Form that summarizes our audit findings. We will provide an original and print-ready master of our reports to the Dare County, North Carolina; however, it is management's responsibility to submit the reporting package (including financial statements, schedule of expenditures of federal awards, summary schedule of prior audit findings, auditors' reports, and a corrective action plan) along with the Data Collection Form to the designated federal clearinghouse and, if appropriate, to pass-through entities. The Data Collection Form and the reporting package must be submitted within the earlier of 30 days after receipt of the auditors' reports or nine months after the end of the audit period, unless a longer period is agreed to in advance by the cognizant agency for audits.

We will provide copies of our reports to The Dare County; however, management is responsible for distribution of the reports and the financial statements. Unless restricted by law or regulation, or containing privileged and confidential information, copies of our reports are to be made available for public inspection.

The audit documentation for this engagement is the property of Potter & Company, PA, and constitutes confidential information. However, pursuant to authority given by law or regulation, we may be requested to make certain audit documentation available to a Cognizant or Oversight Agency for Audit or its designee, a federal agency providing direct or indirect funding, or the U.S. General Accounting Office for purposes of a quality review of the audit, to resolve audit findings, or to carry out oversight responsibilities. We will notify you of any such request. If requested, access to such audit documentation will be provided under the supervision of Potter & Company, PA personnel. Furthermore, upon request, we may provide copies of selected audit documentation to the aforementioned parties. These parties may intend, or decide, to distribute the copies or information contained therein to others, including other governmental agencies.

The audit documentation for this engagement will be retained for a minimum of five years after the date the auditors' report is issued or for any additional period requested by the Cognizant Agency. If we are aware that a federal awarding agency, pass-through entity, or auditee is contesting an audit finding, we will contact the party(ies) contesting the audit finding for guidance prior to destroying the work papers.

Robert W. Taylor, CPA, is the engagement partner and is responsible for supervising the engagement and signing the report or authorizing another individual to sign it.

We expect to begin our audit in May 2019 and to issue our reports no later than October 31, 2019. Our fee for these services will be \$66,500. The fee is based on anticipated cooperation from your personnel and the assumption that unexpected circumstances will not be encountered during the audit. If significant additional time is necessary for other audit procedures not anticipated, procedures of a bookkeeping nature, preparation of schedules

or reconciliations for the audit, including adjusting journal entries, fixed asset reconciliations, construction project reconciliations or assistance with preparation of the Comprehensive Annual Financial Report, we will discuss these procedures with Management and bill you at the following discounted hourly rates:

	<u>Discounted Hourly Rates</u>
Partner	\$250
Manager	175
Other Team Members	125
Clerical	50

*Government Auditing Standards* require that we provide you with a copy of our most recent external peer review report and any letter of comment, and any subsequent peer review reports and letters of comment received during the period of the contract. Our 2016 peer review report accompanies this letter

We appreciate the opportunity to be of service to the Dare County, North Carolina and believe this letter accurately summarizes the significant terms of our engagement. If you have any questions, please let us know. If you agree with the terms of our engagement as described in this letter, please sign the enclosed copy and return it to us.

Very truly yours,

POTTER & COMPANY, P.A.

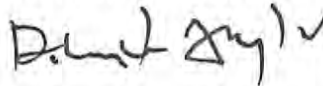

Robert W. Taylor, CPA/PFS

---

RESPONSE:

This letter correctly sets forth the understanding of the Dare County, North Carolina.

By: \_\_\_\_\_

Title: \_\_\_\_\_

Date: \_\_\_\_\_





Personal attention. Verifiable results.

CERTIFIED PUBLIC ACCOUNTANTS | BUSINESS CONSULTANTS | WEALTH ADVISORS | HEALTHCARE PRACTICE CONSULTANTS

## SYSTEM REVIEW REPORT

To: The Owners of Potter & Company, P.A. and the Peer Review Committee of the North Carolina Association of Certified Public Accountants

We have reviewed the system of quality control for the accounting and auditing practice of Potter & Company, P.A. (the Firm) in effect for the year ended December 31, 2015. Our peer review was conducted in accordance with the Standards for Performing and Reporting on Peer Reviews established by the Peer Review Board of the American Institute of Certified Public Accountants. As part of our peer review, we considered reviews by regulatory entities, if applicable, in determining the nature and extent of our procedures. The Firm is responsible for designing a system of quality control and complying with it to provide the Firm with reasonable assurance of performing and reporting in conformity with applicable professional standards in all material respects. Our responsibility is to express an opinion on the design of the system of quality control and the Firm's compliance therewith based on our review. The nature, objectives, scope, limitations of, and the procedures performed in a System Review are described in the standards at [www.aicpa.org/prsummary](http://www.aicpa.org/prsummary).

As required by the standards, engagements selected for review included engagements performed under *Government Auditing Standards* and audits of employee benefit plans.

In our opinion, the system of quality control for the accounting and auditing practice of the Firm in effect for the year ended December 31, 2015, has been suitably designed and complied with to provide the Firm with reasonable assurance of performing and reporting in conformity with applicable professional standards in all material respects. Firms can receive a rating of *pass*, *pass with deficiency(ies)*, or *fail*. Potter & Company, P.A. has received a peer review rating of *pass*.

Certified Public Accountants  
Greensboro, North Carolina

May 25, 2016



**DMJ & Co., PLLC**

703 Green Valley Road, Suite 201, Greensboro, NC 27408 • PO Box 9258, Greensboro, NC 27429-0258  
T 336-275-9886 • F 336-275-1129 • W [dmj.com](http://dmj.com)

Member of CPAAmerica International



*Tax Collector's Report*

**Description**

March 2019 Releases over \$100  
March 2019 Refunds over \$100  
March 2019 NCVTS Refunds over \$100

**Board Action Requested**

Approved

**Item Presenter**

Becky Huff, Tax Collector

# Release Report for REAL ESTATE and PERSONAL PROPERTY

(Releases over (\$100.00) )

MONTH: MARCH

DATE RANGE: 3/1/2019 - 3/31/2019

SUBMITTED BY: Becky Huff

Taxpayer Name	Juris	Parcel#	Bill Year	AR	Reason	Released Value	Tax Released
MURPHY, CHRISTOPHER W	07	004221000	2018	20	REMOVED PREVIOUS OWNER'S BOAT	-89,095.00	-841.72
<b>Total Tax Released:</b>							<b>-841.72</b>

**Refund Report for REAL ESTATE and PERSONAL PROPERTY**

*(Refunds over \$100.00 )*

**MONTH: March**

**DATE RANGE: 3/1/2019 - 3/31/2019**

**SUBMITTED BY: Becky Huff**

<u>Taxpayer Name</u>	<u>Parcel</u>	<u>Bill Yr</u>	<u>Reason</u>	<u>Refund Amount</u>
HEWITT, CARLTON W	020540000	2015	Refund from release/adjustment	-124.34
CHAPPELL, JAMES L JR CO-TTEE	020540000	2016	Refund from release/adjustment	-124.34
CHAPPELL, JAMES L JR CO-TTEE	020540000	2017	Refund from release/adjustment	-131.74
J/M FAMILY LIMITED PARTNERSHIP	000507021	2018	Overpayment	-9,182.11
SWARUP, JITENDA	002774000	2018	Overpayment	-33,421.83
LAMBODERA HOLDINGS LLC	003711000	2018	Overpayment	-24,800.29
MURPHY, CHRISTOPHER W	004221000	2018	Refund from release/adjustment	-841.72
THOMPSON, ANDREW	004775000	2018	Overpayment	-1,769.87
LOWE, KEELY JEFFERS	005789000	2018	Overpayment	-100.00
JACKSON, BRADLEY SCOTT	007759012	2018	Overpayment	-1,750.75
NEWMAN, KENNETH D TTEE	009346000	2018	Overpayment	-563.25
THE PARKER HOUSE LLC	010045000	2018	Overpayment	-4,160.19
VANDERBEEK, KEITH D	010150000	2018	Overpayment	-2,417.91
JONES, PATRICIA A	010501002	2018	Overpayment	-492.72
BROWN, GEORGE C	015235000	2018	Overpayment	-99.93
BURRUS, LUTHER D III	015558000	2018	Overpayment	-165.00
BARRIS, ROBERT D	017043000	2018	Overpayment	-151.10
FLYNN, BRIANNA KELLEY	019769000	2018	Refund from release/adjustment	-132.73
CHAPPELL, JAMES L JR CO-TTEE	020540000	2018	Refund from release/adjustment	-131.74
INGBER, KEITH GEOFFREY	022283000	2018	Overpayment	-173.28
AUSTIN, FAYE DYKSTRA	023476002	2018	Overpayment	-3,112.56
HANCOCK, ROBERT B	025818025	2018	Overpayment	-4,704.59
SIMPSON, M B JR HEIRS	026304000	2018	Overpayment	-219.07
JACKSON, BRADLEY SCOTT	026505000	2018	Overpayment	-1,118.95
SUTHARD CARRIE	027295000	2018	Overpayment	-741.92
				<b>-90,631.93</b>



# North Carolina Vehicle Tax System

## NCVTS Pending Refund report

March 2019

Payee Name	Primary Owner	Address 1	Address 3	Refund Type	Refund Reason	Tax Jurisdiction	Change	Interest Change	Total Change
REIFSCHNEIDER, BLAKE LEE	REIFSCHNEIDER, BLAKE LEE	287 N DOGWOOD TRL	SOUTHERN SHORES, NC 27949	Proration	Tag Surrender	C99	(\$184.98)	\$0.00	(\$184.98)
						T20	(\$86.59)	\$0.00	(\$86.59)
						Refund		\$271.57	
<b>Refund Total:</b>									<b>\$271.57</b>
Tax Jurisdiction	District Type	Net Change							
C99	COUNTY	(\$184.98)							
T20	CITY	(\$86.59)							
<b>Total</b>		<b>(\$271.57)</b>							





*Board Appointments*

**Description**

The Dare County Board of Commissioners will consider the following Board Appointments:

Dare County Board of Adjustment  
Senior Tar Heel Legislative Delegates  
Veterans Advisory Council

Complete information about the appointments will appear after this page.

Upcoming Board Appointments for the next three months are listed at the end.

**Board Action Requested**

Make Board Appointments and Announce Upcoming Appointments

**Item Presenter**

Robert Outten, County Manager

## **BOARD APPOINTMENT SUMMARY – May 7, 2019**

### **Dare County Board of Adjustment**

- The following terms expire this month:  
Shelly R. Jones, Thomas Murphy
- Both would like to be reappointed.
- Applications have been received from:  
Michelle Estelle Lewis, Allen Moran, William Simmonds, Amanda Hooper Walters

### **Senior Tar Heel Legislative Delegates**

- Legislative Delegate Kaye White has informed the Board that Mary Ellen Hawthorne can no longer serve as the “Alternate” to the Senior Tar Heel Legislature due to health reasons. An application has been submitted by Sue Kelly, who is willing to serve as the Alternate to the Senior Tar Heel Legislature.

### **Veterans Advisory Council**

- The following term expires this month:  
Steve Goodheart
- Steve Goodheart would like to be reappointed.
- Jack Leonard has submitted his resignation
- Russell Laney has submitted his resignation
- The Veterans Advisory Council recommends that Steve Goodheart be reappointed, Richard Probst replace Jack Leonard, Robert Yanacek replace Russell Laney
- Applications have been received from:  
George Berry, Kenneth Bukantas, Walter P. Burkheimer, Jr., Michael Keating, Jack Overman, Richard Probst, Robert Yanacek

## **UPCOMING BOARD APPOINTMENTS**

June: Albemarle Region Resource Conservation and Development Council (RC&D)  
Hatteras Community Center Board  
Juvenile Crime Prevention Council (JCPC)  
Land Transfer Tax Appeals Board  
Library Board – Dare  
Manns Harbor Community Center Board  
Roanoke Island Community Center Board  
Rodanthe, Waves, Salvo Community Center Board  
Waterways Commission

July:            Airport Authority  
                  East Lake Community Center Board  
                  Game and Wildlife Commission  
                  Parks and Recreation Advisory Council  
                  Wanchese Community Center Board

August:        ABC Board  
                  Dare County Center Advisory Board  
                  Jury Commission  
                  Stumpy Point Community Center Board



*Dare County Board of Adjustment*

**Description**

See Attached Summary

**Board Action Requested**

Take Appropriate Action

**Item Presenter**

Robert Outten, County Manager

May, 2019

**BOARD APPOINTMENTS**

**DARE COUNTY BOARD OF ADJUSTMENT**

(Three Year Term)

The Board of Adjustment meets to hear variances and appeals related to land use issues in the unincorporated areas of Dare County. The Chair is appointed by the Board of Commissioners and the Planning Department serves as administrative staff for this Board.

The following terms expire this month:

**Shelly R. Jones**

(Current Term 10/17 – 5/19)

(Originally Apptd. 10/17)

**Thomas Murphy**

(Current Term 5/16-5/19)

(Originally Apptd. 6/03)

Both would like to be reappointed.

Applications have been received from:

Michelle Estelle Lewis

Allen Moran

William Simmonds

Amanda Hooper Walters

Other Members:  
See attached list



APPLICATION FOR APPOINTMENT TO  
DARE COUNTY ADVISORY BOARDS AND COMMITTEES

The Dare County Board of Commissioners believes all citizens should have the opportunity to participate in governmental decisions. One way of participating is by serving as a citizen member on one of the county's advisory boards or committees. If you would like to be considered for appointment to an advisory board or committee, please complete the form below and mail to Janice Williams, P.O. Box 1000, Manteo, N.C. 27954 or fax it to her at 473-1817, or send it by email to janicew@darenc.com

Advisory Board or Committee interested in:

1<sup>st</sup> choice Zoning Board of Adjustment

2<sup>nd</sup> choice Land Transfer Tax Appeals Board

3<sup>rd</sup> choice Library Board (East Albemarle Region)

Name Michelle Estelle Lewis

Address 514 Sir Walter Raleigh Street

City/State/Zip Manteo, N.C. 27954

Email Address MichelleELewis@gmail.com

Telephone Home: (252)473-3151

Business: (203)823-7478

Resident of Dare County:  yes  no

Occupation: Clergy- Youth Director Mount Olivet UMC

Business Address: 300 Ananias Dare Street Manteo, N.C.

Educational background:

B.A.-ECSU, M.A. Regent Univ., M.E.S.c.- Yale Univ.,

M.Div. Yale Univ., Doctorate- Emory Univ.

Business and civic experience and skills:

I have worked both nationally and internationally, and  
served as an advisor at the U.N. for a period of time.

Other Boards/Committees/Commissions on which you presently serve:

I do not currently serve on other boards, and am willing to serve where my skills can be best used.

REFERENCES

List three persons who are not related to you and who have definite knowledge of your qualifications for the position for which you are applying.

Name	Business/Occupation	Address	Telephone
Susan Lee	Dare Co. Teacher Ret.	N.C.	(252) 441-1450
Craig Fitzsimmons	Clergy-Ret.	N.Y.	(573) 356-9516
Marsha Lee	NPS-Ret.	N.C.	(510)750-8879

I understand this application will be kept on the active file for three years and I hereby authorize Dare County to verify all information included in this application.

Date: 3/6/2019 Signature of applicant: \_\_\_\_\_

FOR OFFICE USE ONLY:

Date received: 3-6-19

APPLICATION FOR APPOINTMENT TO  
DARE COUNTY ADVISORY BOARDS AND COMMITTEES

The Dare County Board of Commissioners believes all citizens should have the opportunity to participate in governmental decisions. One way of participating is by serving as a citizen member on one of the county's advisory boards or committees. If you would like to be considered for appointment to an advisory board or committee, please complete the form below and mail to Janice Williams, P.O. Box 1000, Manteo, N.C. 27954 or fax it to her at 473-1817, or send it by email to janicew@darenc.com

Advisory Board or Committee interested in:

- 1<sup>st</sup> choice Planning Board      4.) Board of Adjustment
- 2<sup>nd</sup> choice ABC Board      5.) Equalization & Review
- 3<sup>rd</sup> choice Tourism Board      6.) Health & Human Services

Name Allen Moran

Address 381 Mother Vineyard Rd

City/State/Zip Manteo, NC 27954

Email Address allenm@darenc.com

Telephone Home: (252) 423-1309

Business: (252) 475-9222

Resident of Dare County:  yes       no

Occupation: Police Officer / Real Estate Broker / Restaurateur

Business Address: 7623 S. Virginia Dare Trl Nags Head, NC

Educational background:

NC licensed real estate broker, NC Justice Academy,

College of the Albemarle

Business and civic experience and skills:

Rotary International Community Service Chair (Manteo, 2012),

U.S. Restaurant Association Board Member



Other Boards/Committees/Commissions on which you presently serve:

NCDOT Board, Roanoke Island Community Center,  
Albemarle Regional Planning Organization,  
Peanut Belt Regional Planning Organization

REFERENCES

List three persons who are not related to you and who have definite knowledge of your qualifications for the position for which you are applying.

Name	Business/Occupation	Address	Telephone
<u>RV Owens</u>	<u>Self-Employed</u>	<u>Manteo, NC</u>	<u>216-8079</u>
<u>Doug Daughtie</u>	<u>Sheriff (Dare)</u>	<u>KDH, NC</u>	<u>216-9898</u>
<u>Marc Basnight</u>	<u>Retired</u>	<u>Manteo, NC</u>	<u>216-6703</u>

I understand this application will be kept on the active file for three years and I hereby authorize Dare County to verify all information included in this application.

Date: 02/02/2018 Signature of applicant: *Alvin*

FOR OFFICE USE ONLY:

Date received: \_\_\_\_\_

APPLICATION FOR APPOINTMENT TO  
DARE COUNTY ADVISORY BOARDS AND COMMITTEES

The Dare County Board of Commissioners believes all citizens should have the opportunity to participate in governmental decisions. One way of participating is by serving as a citizen member on one of the county's advisory boards or committees. If you would like to be considered for appointment to an advisory board or committee, please complete the form below and mail to Janice Williams, P.O. Box 1000, Manteo, N.C. 27954 or fax it to her at 473-1817, or send it by email to janicew@darenc.com

Advisory Board or Committee interested in:

1<sup>st</sup> choice Dare County Waterways Commission

2<sup>nd</sup> choice Dare County Board of Adjustment

3<sup>rd</sup> choice ABC Board

Name William Simmonds

Address 147 W. Oak Knoll Dr

City/State/Zip Nags Head, NC 27959

Email Address wsimm1017@gmail.com

Telephone Home: 321-607-4241

Business: \_\_\_\_\_

Resident of Dare County:  yes  no

Occupation: Recently retired NASA, Kennedy Space Center, Florida

Business Address: \_\_\_\_\_

Educational background:

BS Mechanical Engineering, Old Dominion University, Masters Engineering Management, George Washington University

Business and civic experience and skills:

Solid Waste Advisory Board - Hampton, Virginia, 1989-1992, Project Manager, (PM) KSC Railroad Bridge upgrades,

PM, Indian River Dredging Project, KSC, NASA & AF Barge and Wharf Terminal Improvement Project, Brevard County, Florida, Youth Science Fair Judge.



Other Boards/Committees/Commissions on which you presently serve:

---

---

REFERENCES

List three persons who are not related to you and who have definite knowledge of your qualifications for the position for which you are applying.

Name	Business/Occupation	Address	Telephone
Steve Milton, PM Chief, NASA	Mail Code LX-D1	John F. Kennedy Space Center, FL 32899	(321) 867-5965
Eric Anderson, Launch & Ops Div. Chief,	Mail Code VAE00	John F. Kennedy Space Center, FL 32899	(321) 867-5000
Ross A. Kearney, retired, former Mayor	Hampton of City,	328 Darby Ave. Hampton, Va. 23663	(757)-268-4081

I understand this application will be kept on the active file for three years and I hereby authorize Dare County to verify all information included in this application.

Date: 08/03/2017 Signature of applicant: *Quinn D. Lewis*

FOR OFFICE USE ONLY:

Date received: 8/9/17

APPLICATION FOR APPOINTMENT TO  
DARE COUNTY ADVISORY BOARDS AND COMMITTEES

The Dare County Board of Commissioners believes all citizens should have the opportunity to participate in governmental decisions. One way of participating is by serving as a citizen member on one of the county's advisory boards or committees. If you would like to be considered for appointment to an advisory board or committee, please complete the form below and mail to Janice Williams, P.O. Box 1000, Manteo, N.C. 27954 or fax it to her at 473-1817, or send it by email to janicew@darenc.com

Advisory Board or Committee interested in:

- 1<sup>st</sup> choice Parks and Recreation
- 2<sup>nd</sup> choice Northeastern Workforce Development
- 3<sup>rd</sup> choice Zoning Board of Adjustments

Name Amanda Hooper Walters

Address 1202 9th Ave

City/State/Zip Kill Devil Hills, NC 27948

Email Address manda.hooper@icloud.com

Telephone Home: 252-202-9923

Business: 252-202-9923

Resident of Dare County:  yes  no

Occupation: Property Manager

Business Address: 1202 9th Ave. KDH, NC 27948

Educational background:

Bachelor of Science, Business Admin, ECU

Assosicate of Arts, College of the Albemarle

Business and civic experience and skills:

Outer Banks Mommy and Me, Board Member 2009-2011: OBX Aquatics Board

Member, 2014-2016: Outer Banks Local Food Council 2013-2016

Other Boards/Committees/Commissions on which you presently serve:

n/a

REFERENCES

List three persons who are not related to you and who have definite knowledge of your qualifications for the position for which you are applying.

Name	Business/Occupation	Address	Telephone
Karen Brown	Chamber of Commerce		252-441-8144
Bob Peele	Wachese Industrial Park		252-473-5867
Sandy Semans	133 Bayview Dr.	Stumpy Point,	252-305-7284

I understand this application will be kept on the active file for three years and I hereby authorize Dare County to verify all information included in this application.

Date: 2/3/2018 Signature of applicant: [Signature]

FOR OFFICE USE ONLY:

Date received: 2/6/18



**DARE COUNTY BOARD OF ADJUSTMENT**

(Initial Staggered Term/Three Year Term)

**The Board of Adjustment meets to hear variances and appeals related to land use issues in the unincorporated areas of Dare County. The Chair is appointed by the Board of Commissioners and the Planning Department serves as administrative staff for this Board.**

<b><u>MEMBER</u></b>	<b><u>TERM EXPIRATION</u></b>	<b><u>ACTION</u></b>
Jay Hart, Chairman P.O. Box 1782 Kill Devil Hills, NC 27948 207-7900 Colington Area	5-30-21	Apptd. 4-05 Reapptd. 5/06,09,12,15 18
Edward Mann, Jr. 415 Highway 64 Manteo, NC 27954 423-1215 eddiemann86@gmail.com Roanoke Island	5-30-20	Apptd. 5/17
<b>Thomas Murphy</b> P.O. Box 147 Rodanthe, NC 27968 987-2656 Hatteras Island	5-30-19	Apptd. 6-03 Reapptd. 5-04,07,10,13, 16
<b>Shelly R. Jones</b> 5013 Martins Point Road Kitty Hawk, NC 27949 261-8878 shellyjones@gmail.com Martins Point Area	5-30-19	Apptd. 10/17
Anna Creef 5297 Mashoes Rd. Manns Harbor, NC 27953 473-3339 Dare Mainland	5-30-20	Apptd. 6-03 Reapptd. 5-05,08,11,14, 17

**ALTERNATES**

Vacant  
Vacant

**NOTES:**

CONTACT INFO: Donna Creef, Planning Director

MEETING DATE: No Set Date

Jay Hart filled unexpired term of Jacob Maestas 4/05.  
Andrew Keeney replaced David Overton (alternate) 4/05.

Patricia Austin apptd. to fill unexpired term of Michael Egan 5/06.  
Roland Bowser replaced Patricia Austin 5/08  
Edward Mann, Jr replaced Roland Bowser 5/17  
Shelly Jones filled unexpired term of David Jones who resigned 10/17.  
Jay Hart appointed Chairman 11/17

**REVISED 5/18**





*Senior Tar Heel Legislative Delegates*

**Description**

See Attached Summary

**Board Action Requested**

Take Appropriate Action

**Item Presenter**

Robert Outten, County Manager

May, 2019

**BOARD APPOINTMENTS**

**SENIOR TAR HEEL LEGISLATIVE DELEGATES**

(Two Year Term)

The Senior Tar Heel Legislature was created by the State Legislature to provide information to senior citizens on the legislative process and matters being considered by the North Carolina General Assembly. Delegates from all 100 counties serve on committees and meet with the Governor and are a spokesperson for the county they represent. Position requires the ability to keep the County Commissioners informed of the Senior Tar Heel Legislative Agenda and to report to other seniors and groups regarding advocacy activities.

Legislative Delegate Kaye White has informed the Board that Mary Ellen Hawthorne can no longer serve as the "Alternate" to the Senior Tar Heel Legislature due to health reasons. An application has been submitted by Sue Kelly, who is willing to serve as the Alternate to the Senior Tar Heel Legislature

APPLICATION FOR APPOINTMENT TO  
DARE COUNTY ADVISORY BOARDS AND COMMITTEES

The Dare County Board of Commissioners believes all citizens should have the opportunity to participate in governmental decisions. One way of participating is by serving as a citizen member on one of the county's advisory boards or committees. If you would like to be considered for appointment to an advisory board or committee, please complete the form below and mail to Janice Williams, P.O. Box 1000, Manteo, N.C. 27954 or fax it to her at 473-1817, or send it by email to janicew@darenc.com

Advisory Board or Committee interested in:

1<sup>st</sup> choice Alternate Delegate, NC Senior Tax Hed Legislature

2<sup>nd</sup> choice \_\_\_\_\_

3<sup>rd</sup> choice \_\_\_\_\_

Name Susanne D. Kelly "Sue"

Address All Sea Village Lane

City/State/Zip Kill Devil Hills NC 27948

Email Address sdkelly927@aol.com

Telephone Home: 252 441 7795

cell Business: 804 833 8980

Resident of Dare County:  yes  no

Occupation: Retired

Business Address: \_\_\_\_\_

Educational background:

BA Hollins University, M.Ed Virginia

Commonwealth University, classroom teacher

Business and civic experience and skills:

Dare County Guardian ad litem

Dare County Friends of Youth

Other Boards/Committees/Commissions on which you presently serve:

3 Boards for Kill Devil Hills  
Please see attached Vita for more info.

REFERENCES

List three persons who are not related to you and who have definite knowledge of your qualifications for the position for which you are applying.

Name	Business/Occupation	Address	Telephone
Brandi Rheubottom		Director Baum Sr. Ctr	252 475 5635
Kaye White	NC Delegate	Sr. Tar Heel Legis	252 258 1375
Ricki Tillett	Supervisor Guardian ad Litem		252 475 5587

I understand this application will be kept on the active file for three years and I hereby authorize Dare County to verify all information included in this application.

Date: 3/15/19 Signature of applicant: Susanne D Kelly

FOR OFFICE USE ONLY:

Date received: 3/26/19



Vita

**Susanne Dandridge Kelly “Sue”**

(residence) 211 Sea Village Lane, Kill Devil Hills, NC 27948

POBox 743, Kitty Hawk, NC 27949 (mail)

252-441-7795, (cell) 804-833-8980

sdkelly927@aol.com

**Education**

Diploma, Virginia Beach Public Schools

BA, Hollins College/University, Political Science

M.Ed., Virginia Commonwealth University, Counseling

**Work Experience--Fulltime**

High School Social Studies Teacher, Virginia Beach Public Schools

President, Virginia Beach Education Association

President, Virginia Education Association/NEA

Director of Negotiations and Organizing, Virginia Education Association (In this position, served as a trainer in leadership development, human relations, crisis organizing, conflict resolution, grievance processing and other personnel matters, developed and delivered a training program for teachers working with children from addictive, abusive and dysfunctional families, registered lobbyist. (Partial list of responsibilities.)

**Volunteer Experience—Current**

Dare County Guardian ad Litem

Training Team, Guardian ad Litem, Diversity and Cultural Awareness

Town of Kill Devil Hills, Community Appearance Commission, Chair

Dare County Friends of Youth mentor

Town of Kill Devil Hills, Personnel Board



Volunteer Experience---Current, continued

Town of Kill Devil Hills, Dangerous Animal Appeal Board

Volunteer, National Park Service, Cape Hatteras National Seashore, Bodie Island Lighthouse

Delivering Home Delivered Meals (AKA Meals on Wheels)

N.E.S.T. Volunteer; Marine Mammal Stranding Network

Volunteer Experience, not current,  
partial list

American Red Cross

Dare Literacy Council, tutor, ESL, GED

Secretary-Treasurer, Local 334, Office and Professional Employees International Union, AFL-CIO

Dog walker for residents of Spring Arbor

Board member and President, Daily Planet, homeless service agency, Richmond VA

Youth facilitator, founding board member and officer, Richmond Organization for Sexual  
Minority Youth

Board member and officer, Richmond Human Rights Foundation, Richmond Action Center  
and several other 501(c)3 organizations

Chair, Virginia Education Association Political Action Committee (worked on numerous political  
campaigns, bipartisan)

Organizer and participant, humanitarian aid and educational trips overseas

Awards

NC Governor's Volunteer Appreciation Award 2018

Outer Banks Lighthouse Society Prism Award 2018

Other skills, interests

Photography, camping, jewelry-making, pets, reading, public speaking, parliamentary  
procedure, plants, kayaking, travel, needlework

**NC Senior Tar Heel Legislative Delegates**  
**(Two Year Term)**

**The Senior Tar Heel Legislative Delegates provides information to senior citizens on the legislative process and matters being considered by the NC General Assembly. Must be at least 60 years of age to serve.**

<b><u>MEMBER</u></b>	<b><u>TERM EXPIRATION</u></b>	<b><u>ACTION</u></b>
Kaye White 423 W. Villa Dunes Dr. Nags Head, NC 27959 252-441-7062	2/21	Apptd. 2/11 Reapptd 2/13,15,17, 19
Mary Ellen Hawthorne, Alternate 114 St. Clair Rd. Kill Devil Hills, NC 27948 252-480-1062	2/21	Apptd. 2/11 Reapptd 2/13,15,17 19

**NOTES:**

- Enacted by Senate Bill 479 (G.S. 143B-181.55)
- Delegates must be 60 yrs. of age or older
- Each county has one delegate and one alternate
- Delegates from all 100 counties serve on committees and meet regularly with the Governor and are a spokesperson for the county they represent. Position requires the ability to keep the County Commissioners informed of Senior Tar Heel Legislative Agenda and to report to other seniors/groups regarding advocacy activities.

**REVISED 2/19**



*Veterans Advisory Council*

**Description**

See Attached Summary

**Board Action Requested**

Take Appropriate Action

**Item Presenter**

Robert Outten, County Manager

May 2019

**BOARD APPOINTMENT**

**VETERANS ADVISORY COUNCIL**  
(Staggered Three Year Terms)

The Veterans Advisory Council serves as a liaison with the community in coordinating services and activities benefiting Veterans and their families. Members of the Veterans Advisory Council solicit information and provide updates about community based activities honoring veterans.

The following Term Expires This Month:

**Steve Goodheart**  
(Current Term 7/18-5/19)  
(Originally Apptd. 7/18)

**Steve Goodheart would like to be reappointed.**

**Jack Leonard has submitted his resignation.  
Russell Laney has submitted his resignation.**

**The Veterans Advisory Council recommends:**

**Steve Goodhart be reappointed  
Richard Probst replace Jack Leonard  
Robert Yanacek replace Russell Laney**

Applications have been received from:

**George Berry  
Kenneth Bukantas  
Walton P. Burkheimer, Jr.  
Michael Keating  
Jack Overman  
Richard Probst  
Robert Yanacek**

Other members:  
See attached list



Janice Williams <janicew@darenc.com>

---

## Applicants

1 message

---

**Patricia O'Sullivan** <patricia.o.sullivan@dcdss.org>  
To: Janice Williams <janicew@darenc.com>

Fri, Apr 26, 2019 at 10:39 AM

Good morning,

Attached are the applications for the 2 new recommendations from the members of the VAC to the Commissioners:

replacing Jack Leonard - Richard Probst  
replacing Russell Laney - Robert Yanacek

The Council is going to vote on who will be Chairman & Co-Chair next month.

Let me know if you have any questions. Thank you

--

**Patricia O'Sullivan**  
*Veteran Services Officer*  
Department of Health & Human Services  
P O Box 669, Manteo, NC 27954  
252.475.5604 - Office  
252.473.6437 - Fax  
[patricia.o.sullivan@dcdss.org](mailto:patricia.o.sullivan@dcdss.org)



---

### 2 attachments

**Probst Application.pdf**  
42K

**Yanacek App.pdf**  
59K



John A. Leonard  
181 Happy Indian Court  
Southern Shores, NC 27949

March 12, 2019

Dare County Board of Commissioners  
P.O. Box 1000  
Manteo, NC 27954  
Attn: Chairman Bob Woodard

Dear Chairman Woodard:

Having served four years - three as chairman - on the Veterans Council Advisory Board I submit my resignation effective March 27, 2019.

This Board has initiated several successful projects during the last four years in following your charge of "helping our county veterans":

We were successful in getting amendments to bylaws for the County and all of the towns therein to allow for hiring preferences for veterans. Our efforts in this as well as our partnerships with the Dare County Transportation and several area non-profits allowed us to identify needy veterans and help them whenever possible. For these efforts we received national recognition as a recipient of a grant from the Bob Woodruff Foundation. Last fall we initiated the first Christmas wreath program to honor veterans interred in our local cemeteries. Again this was achieved through partnerships with the Outer Banks Woman's Club and local Girl Scout troops.

Thank you for the opportunity to serve and for your support of this organization during my tenure. I am sure it will continue to be responsive to the needs of our vets.

Very truly yours,

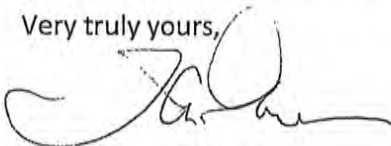

John A. Leonard

Russell Laney  
412 Woodard Rd.  
Kitty Hawk, NC 27949

Chairman, Dare County Board of Commissioners  
Members, Dare County Board of Commissioners  
Dare County Manager  
Chairman, Dare County Veterans Advisory Council  
Members, Dare County Veterans Advisory Council

January 24, 2019

Dear Chairman Woodard:

I hereby submit my resignation from the Dare County Veterans Advisory Council.

I have been privileged and honored with the distinction of serving on the Veterans Advisory Council. While my reasons for resigning are personal, I intend to continue my support of the Council and the Veterans of Dare County as best I can.

I am willing to continue to serve on the Council until a new member is appointed, but fully understand that may not be in the best interest to our Veterans or the Council.

Thank you for opportunity to serve Dare County and our Veterans over the last two plus years.

Respectfully yours,

Russell Laney

February 21, 2019

Dare County Board of Commissioners  
P.O. Box 1000,  
Manteo, NC 27954

Dear Commissioners,

Please find enclosed, together with this cover letter and recommendation from fellow council member Marsha Brown, my completed "Application for "Appointment to Dare County Advisory Boards and Committees" for resubmittal to you at this time. As most of you are aware, I am already a sitting member of the DC Veterans Advisory Council, however, my council seat status is due to expire in May of this year due to my having been brought aboard our council to serve out the remaining term of my friend and council predecessor Carl Reiber following his departure from Dare County.

It is my desire to continue making contributions in supporting our county veterans' needs by continuing to serve on the DC Veterans Advisory Council. For this reason, I approach the Board with my request to extend my council membership for a full three-year full term. Please know that I thank all of you for your considerations in granting my request.

Respectfully,

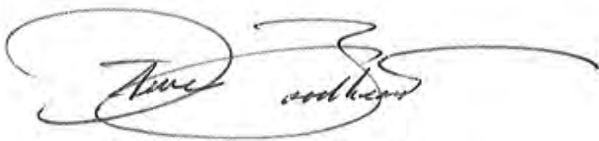
A handwritten signature in black ink, appearing to read "Steven B. Goodheart", with a large, sweeping flourish extending to the right.

Steven B. Goodheart





Steven Goodheart &lt;stevegoodheart@gmail.com&gt;

---

## Just a thank you...

---

**Marsha** <giglineheroes@aol.com>  
To: stevegoodheart@gmail.com

Wed, Feb 20, 2019 at 5:37 PM

Dear Steve,

In the midst of preparing notes for our next D.C.V.A.C. meeting next Thursday, I couldn't help but remember the first time I met you and the impression both you and your sweet wife Patty made on me.

I noticed immediately your pride, having served the U. S. Coast Guard and it became apparent very quickly how much you cared about all our veterans as well as your obvious interest in serving on our Veterans Advisory Council. Later, after learning Carl Reiber would exit his membership position prematurely in preparation for his pending marriage and extended residency in Georgia, I was like everyone else, sad to see him leave but happy to learn that you had applied for membership and that you were unanimously supported by our sitting Council members. Your background, experience, communication skills and professional nature made you the perfect candidate as a viable replacement for Carl's seat and after you were officially appointed by our Commissioners, we all celebrated your appointment.

As a fellow member, it's been my great honor and privilege to work beside you and five other veteran members, both men and women. I've appreciated first-hand all of your dedication, not simply by 'affiliation' to the Council but as evidenced in your reliable attendance, focus on topic matter, follow up with tasks and your eagerness to help others. In general, our members embrace opportunities to seek solutions to challenging projects of which you have been a primary example. You've been a great asset Steve and I can only imagine the (your) accomplishments yet to come. Your unwavering desire to expand our veteran outreach and to simply love our vets and their family members is exceptional. Without a doubt, my wonderful husband, Billy, must be so proud in Heaven of all the great things you and all of our fellow Council members have achieved for veterans in Dare County and beyond.

Together our Commissioners and our D.C.V.A. Council 'family' have made a big difference in our veterans lives as they have personally expressed to me **countless** times. I thank our good Lord for our County leadership supporting not only our Council as they do but also for appointing you as a Council member. I pray that your tenure will be extensive based on your contribution thus far and in the future, it will no doubt be immeasurable.

Thank you,  
Marsha M. Brown  
Dare County Veterans Advisory Council  
Member & Events Coordinator .

APPLICATION FOR APPOINTMENT TO  
DARE COUNTY ADVISORY BOARDS AND COMMITTEES

The Dare County Board of Commissioners believes all citizens should have the opportunity to participate in governmental decisions. One way of participating is by serving as a citizen member on one of the county's advisory boards or committees. If you would like to be considered for appointment to an advisory board or committee, please complete the form below and mail to Janice Williams, P.O. Box 1000, Manteo, N.C. 27954 or fax it to her at 473-1817, or send it by email to janicew@darenc.com

Advisory Board or Committee interested in:

1<sup>st</sup> choice Dare County Veterans Advisory Council

2<sup>nd</sup> choice \_\_\_\_\_

3<sup>rd</sup> choice \_\_\_\_\_

Name Steven B. Goodheart

Address 101 Trinitie Drive

City/State/Zip Duck, NC 27949

Email Address stevegoodheart@gmail.com

Telephone Home: (252) 715-4577

Business: (703) 861-5476

Resident of Dare County:  yes  no

Occupation: Retired

Business Address: N/A

Educational background:  
BS, Alameda Univ; Bus. Admin/Bus. Mgmt; VCU;  
Northwestern State Univ.

Business and civic experience and skills:  
Career IT; sr level admin/sales/mktg/bus. dvlpmt.  
local/state/fed govt; intel; civilian and private sector



Other Boards/Committees/Commissions on which you presently serve:

Veterans Advisory Council (current member)

American Legion (current member)

REFERENCES

List three persons who are not related to you and who have definite knowledge of your qualifications for the position for which you are applying.

Name	Business/Occupation	Address	Telephone
------	---------------------	---------	-----------

Bob Woodard

Wally Overman

Rob Ross

I understand this application will be kept on the active file for three years and I hereby authorize Dare County to verify all information included in this application.

Date: 2/21/19 Signature of applicant: \_\_\_\_\_

FOR OFFICE USE ONLY:

Date received: 2/22/19

### APPLICATION FOR APPOINTMENT TO DARE COUNTY ADVISORY BOARDS AND COMMITTEES

The Dare County Board of Commissioners believes all citizens should have the opportunity to participate in governmental decisions. One way of participating is by serving as a citizen member on one of the county's advisory boards or committees. If you would like to be considered for appointment to an advisor board or committee, please complete the form below and mail to Rhonda Creef, Dare County Deputy Clerk to the Board, P.O. Box 1000, Manteo, N.C. 27954 or fax it to her at 473-6312.

Advisory Board or Committee interested in:

1<sup>st</sup> choice Dare County ABC Board

2<sup>nd</sup> choice Dare County Veteran Advisory Board

3<sup>rd</sup> choice ~~Dare County Planning Board~~ <sup>Apptd. 7/16</sup> Parks & Recreation Advisory Board GB

Name: George H. Berry

Address: 239 North Dogwood Trail

City/State/Zip Southern Shores, NC 27949

Telephone Home: (252) 261-1278

Business: (703) 473-0528

Resident of Dare County:  yes  no

Occupation: CEO Starfish Services, Inc.

Business Address: Same as above

Educational background:

U of Utah 1972, Navy Postgraduate School 1978, Retired Navy Commander

Business and civic experience and skills:

National Security Intelligence support for over 45 years. Manage beach rental business over 20 years. Currenly attending Vet Adv Board meetings. Member of OBX Home brewers Club.

Other Boards/Committees/Commissioners presently serving on:

Board, Committee, or Commission:

None

Have been attending VET advisory board mgs

Expiration Date of Terms: \_\_\_\_\_

REFERENCES

List three persons who are not related to you and who have definite knowledge of your qualifications for the position for which you are applying.

Name	Business/Occupation	Address	Telephone
Wally Overman, Commissioner			
Beverly Boswell, Commissioner			
Jack Shea, Commissioner			

I understand this application will be kept on the active file for five years and I hereby authorize Dare County to verify all information included in this application.

Date: 6/29/16 Signature of applicant: [Signature]

FOR OFFICE USE ONLY:

Date received: 6/29/16

Date forwarded to County Commissioners: \_\_\_\_\_

APPLICATION FOR APPOINTMENT TO  
DARE COUNTY ADVISORY BOARDS AND COMMITTEES

The Dare County Board of Commissioners believes all citizens should have the opportunity to participate in governmental decisions. One way of participating is by serving as a citizen member on one of the county's advisory boards or committees. If you would like to be considered for appointment to an advisory board or committee, please complete the form below and mail to Janice Williams, P.O. Box 1000, Manteo, N.C. 27954 or fax it to her at 473-1817, or send it by email to janicew@darenc.com

Advisory Board or Committee interested in:

1<sup>st</sup> choice VA Advisory (VETS)

2<sup>nd</sup> choice SENIOR Advisory Board

3<sup>rd</sup> choice \_\_\_\_\_

Name KENNETH BUKANTAS

Address 288 WAY MYRTLE TR

City/State/Zip SOUTHERN CHOICES NC 27949

Email Address Kenbukantas@outlook.com

Telephone Home: 252 2617322

Business: \_\_\_\_\_

Resident of Dare County:  yes  no

Occupation: Retired Accountant

Business Address: N/A

Educational background:

8 yr USMC for military experience  
Enrolled Agent - IRS Tax

Business and civic experience and skills:

Business owner - Accounting Practice  
for 30 years.

Other Boards/Committees/Commissions on which you presently serve:

\_\_\_\_\_  
\_\_\_\_\_

REFERENCES

List three persons who are not related to you and who have definite knowledge of your qualifications for the position for which you are applying.

Name	Business/Occupation	Address	Telephone
Jack Shea			261 4158
Wally Overman			216 6042
Carole Waznecki			207 6776

I understand this application will be kept on the active file for three years and I hereby authorize Dare County to verify all information included in this application.

Date: 11/1/18 Signature of applicant: [Signature]

FOR OFFICE USE ONLY:

Date received: 11-2-18



APPLICATION FOR APPOINTMENT TO  
DARE COUNTY ADVISORY BOARDS AND COMMITTEES

The Dare County Board of Commissioners believes all citizens should have the opportunity to participate in governmental decisions. One way of participating is by serving as a citizen member on one of the county's advisory boards or committees. If you would like to be considered for appointment to an advisory board or committee, please complete the form below and mail to Janice Williams, P.O. Box 1000, Manteo, N.C. 27954 or fax it to her at 473-1817, or send it by email to [janicew@darenc.com](mailto:janicew@darenc.com)

Advisory Board or Committee interested in:

1<sup>st</sup> choice Airport Authority

2<sup>nd</sup> choice Veterans Advisory Council

3<sup>rd</sup> choice \_\_\_\_\_

Name Walton P. Burkheimer, Jr. ("Pete")

Address 302 Saint Louis Street

City/State/Zip Kill Devil Hills, NC 27948

Email Address wpburkheimer1@gmail.com

Telephone Home: 757-478-5970

Business: \_\_\_\_\_

Resident of Dare County:  yes  no

Occupation: Civil Engineer

Business Address: same as residence

Educational background:  
BS Civil Engineering, NC State University 1969

Business and civic experience and skills:

Licensed Professional Engineer, NC & VA; Town Engineer for KDH 13 years

Active @ KHUMC. 45 yrs active in civic, community affairs. Former liaison to another airport authority

Other Boards/Committees/Commissions on which you presently serve:

**None**

REFERENCES

List three persons who are not related to you and who have definite knowledge of your qualifications for the position for which you are applying.

Name	Business/Occupation	Address	Telephone
Charles Davidson	/ doctor /	3618 S Old Nags Head Woods Rd, Nags Head, NC 27959	/ 252-548-9141

Debora Diaz	/ Town Manager, KDH /	102 Town Hall Dr, Kill Devil Hills, NC 27948	/ 252-449-5300
-------------	-----------------------	--	----------------

Robert Woodard, Chair, Dare County BOC	/	2305 Bay Dr, Kill Devil Hills, NC 27948	/ 252-216-8240
--	---	---	----------------

I understand this application will be kept on the active file for three years and I hereby authorize Dare County to verify all information included in this application.

Date: November 9, 2018

Signature of applicant:

*Walter P. [Signature]*

FOR OFFICE USE ONLY:

Date received: 11-13-18

### APPLICATION FOR APPOINTMENT TO DARE COUNTY ADVISORY BOARDS AND COMMITTEES

The Dare County Board of Commissioners believes all citizens should have the opportunity to participate in governmental decisions. One way of participating is by serving as a citizen member on one of the county's advisory boards or committees. If you would like to be considered for appointment to an advisory board or committee, please complete the form below and mail to Rhonda Creef, Dare County Deputy Clerk to the Board, P.O. Box 1000, Manteo, N.C. 27954 or fax it to her at 473-6312.

Advisory Board or Committee interested in:

1<sup>st</sup> choice Dare County Veterans Advisory Council

2<sup>nd</sup> choice \_\_\_\_\_

3<sup>rd</sup> choice \_\_\_\_\_

Name: Michael A. Keating

Address: 5213 Lunar Drive

City/State/Zip Kitty Hawk, N.C. 27949

Telephone Home: 252-489-7311

Business: N/A

Resident of Dare County:  yes  no

Occupation: Retired

Business Address: N/A

Educational background:

Associates Degree CoA Dare County Campus

Business and civic experience and skills:

Retired as Customer Svc. Mgr. from City Beverage Co  
Assistant Sr. Vice Commandant Marine Corps League O BX

In my younger years I coached Little League Baseball  
Six years total Marine Corps  
Also a member of the Eagles Club where I have  
assisted with several fundraisers.

Other Boards/Committees/Commissioners presently serving on:

Board, Committee, or Commission:

N/A

Expiration Date of Terms: N/A

REFERENCES

List three persons who are not related to you and who have definite knowledge of your qualifications for the position for which you are applying.

Name	Business/Occupation	Address	Telephone
Frank Draper	retired	P.O. Box 574 Kitty Hawk, N.C.	252-255-0619
Robert Yanacek	sect. Mgr. Walmart	1718 Creek St Kill Devil Hills, N.C.	252-205-5026
Don Hudson	retired	P.O. Box 231 Corolla, N.C.	703-863-1786

I understand this application will be kept on the active file for five years and I hereby authorize Dare County to verify all information included in this application.

Date: 10 May 2016 Signature of applicant: Michael A. Keating

FOR OFFICE USE ONLY:

Date received: 5/26/16

Date forwarded to County Commissioners: \_\_\_\_\_







Other Boards/Committees/Commissions on which you presently serve:

NONE

REFERENCES

List three persons who are not related to you and who have definite knowledge of your qualifications for the position for which you are applying.

Name	Business/Occupation	Address	Telephone
CLARENCE SKINNER			
Dr. Charles Davidson			
day wheels			

I understand this application will be kept on the active file for three years and I hereby authorize Dare County to verify all information included in this application.

Date: 1/26/17 Signature of applicant: [Signature]

FOR OFFICE USE ONLY:

Date received: 1/26/17

APPLICATION FOR APPOINTMENT TO  
DARE COUNTY ADVISORY BOARDS AND COMMITTEES

The Dare County Board of Commissioners believes all citizens should have the opportunity to participate in governmental decisions. One way of participating is by serving as a citizen member on one of the county's advisory boards or committees. If you would like to be considered for appointment to an advisory board or committee, please complete the form below and mail to Janice Williams, P.O. Box 1000, Manteo, N.C. 27954 or fax it to her at 473-1817, or send it by email to janicew@darenc.com

Advisory Board or Committee interested in:

1<sup>st</sup> choice VETERAN'S ADVISORY COUNCIL MEMBER

2<sup>nd</sup> choice \_\_\_\_\_

3<sup>rd</sup> choice \_\_\_\_\_

Name RICHARD A. PROBST

Address 1806 UPPER DUNE RD.

City/State/Zip KILL DEVIL HILLS, NC 27948

Email Address RPROBST60 @ YAHOO.COM

Telephone Home: (502) 592-7659

Business: \_\_\_\_\_

Resident of Dare County:  yes  no

Occupation: RETIRED

Business Address: \_\_\_\_\_

Educational background:

ASSOCIATES Degree in ELECTRONIC ENGINEERING Technology

Business and civic experience and skills:

RETIRED ARMY, MAINTENANCE Tech FOR AUTOMOTIVE PARTS COMPANY,  
RETIRED, EDUCATOR AT JENNETTES PIER, (NOW VOLUNTEER)  
ASSISTS VETERANS ADVISORY DURING EVENTS (i.e.) DARE DAYS,  
SEA FOOD FESTIVAL, SET IN ON MEETINGS IN CASE  
ASSISTANCE IS NEEDED FROM THE VFW,

Other Boards/Committees/Commissions on which you presently serve:

Present Commander of New Post 10950 Outer Banks

Previous Positions Held, Chaplain and Sr Vice CDR

REFERENCES

List three persons who are not related to you and who have definite knowledge of your qualifications for the position for which you are applying.

Name	Business/Occupation	Address	Telephone
<u>CLARK TWIDDY</u>	<u>Twiddy + Co.</u>	<u>(252) 216-6920</u>	
<u>CARL REIBER</u>			<u>(571) 236-9823</u>
<u>Russ LANEY</u>			<u>(571) 239-3054</u>

I understand this application will be kept on the active file for three years and I hereby authorize Dare County to verify all information included in this application.

Date: 8 APR 2019 Signature of applicant: Rubens P. [Signature]

FOR OFFICE USE ONLY:

Date received: 4/26/19

APPLICATION FOR APPOINTMENT TO  
DARE COUNTY ADVISORY BOARDS AND COMMITTEES

The Dare County Board of Commissioners believes all citizens should have the opportunity to participate in governmental decisions. One way of participating is by serving as a citizen member on one of the county's advisory boards or committees. If you would like to be considered for appointment to an advisory board or committee, please complete the form below and mail to Janice Williams, P.O. Box 1000, Manteo, N.C. 27954 or fax it to her at 473-1817, or send it by email to [janicew@darenc.com](mailto:janicew@darenc.com)

Advisory Board or Committee interested in:

1<sup>st</sup> choice Dare County Veterans Advisory Council

2<sup>nd</sup> choice \_\_\_\_\_

3<sup>rd</sup> choice \_\_\_\_\_

Name Robert J. Yanacek

Address 1718 Creek Street

City/State/Zip Kill Devil Hills, NC 27948-9481

Email Address yanacek.rj@marinevetsobx.org

Telephone Home: 252-305-5026 (mobile)

Business: None

Resident of Dare County:  yes  no

Occupation: Support Manager / U.S. Marine Corps (Ret)

Business Address: Walmart, 5400 Croatan Highway, Kitty Hawk, NC 27949

Educational background:

Diploma, Euclid Senior High School, 1977

Baccalaureate, Cleveland State University, 1982

Business and civic experience and skills:

U.S. Marine Corps, 1978 through 2001

\_\_\_\_\_



Other Boards/Committees/Commissions on which you presently serve:

Marine Corps League Outer Banks Detachment (Staff Officer)

---

REFERENCES

List three persons who are not related to you and who have definite knowledge of your qualifications for the position for which you are applying.

Name	Business/Occupation	Address	Telephone
Russ Laney,	USMC (Ret),	412 Woodard Rd, Kitty Hawk, NC, 27949,	540-239-3054
Dale Draper,	Retired,	192 Bright Lantern Ln, Kitty Hawk, NC, 27949,	240-354-6477
Dan Hudson,	USMC (Ret),	Post Office Box 231, Corolla, NC 27927,	703-863-1786

I understand this application will be kept on the active file for three years and I hereby authorize Dare County to verify all information included in this application.

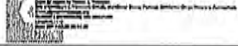
Date: 22 April 2019 Signature of applicant: Robert J. Yanacek 

---

FOR OFFICE USE ONLY:

Date received: 4/26/19



## **Robert J. Yanacek**

Originally from Euclid, Ohio, Robert is a graduate of Euclid Senior High School and Cleveland State University. He enlisted into the United States Marine Corps Reserve in 1978 and received training as an infantryman while pursuing his undergraduate studies in history. Upon completing those studies he entered active service in the Marine Corps in 1982 where he served in various billets and assignments until his retirement at the rank of Master Sergeant with twenty-three years of service. Following his retirement, Robert, his wife, and their seven children moved to Kill Devil Hills where he currently resides. Robert is presently employed as a support manager at the Wal-Mart store in Kitty Hawk. In addition to their children, Robert and his wife, Diane, are also the proud grandparents of five. He is a charter-member of the Marine Corps League Outer Banks Detachment and has served in a number of billets including sergeant-at-arms, junior vice-commandant, senior vice-commandant, and most recently, adjutant. In addition to his membership in the Outer Banks Detachment Robert is also a member of the Marine Corps Veterans Association and the Marine Bombing Squadron Six-Thirteen Association. His personal decorations include the Meritorious Service Medal, the Navy Commendation Medal with two gold stars in lieu of the second and third awards, and the Navy Achievement Medal with one gold star in lieu of a second award.



**VETERANS ADVISORY COUNCIL**  
**(Staggered/Three Year Term)**

The Veterans Advisory Council serves as a liaison with the community in coordinating services and activities benefiting Veterans and their families. Members of the Veterans Advisory Council solicit information and provide updates about community based activities honoring Veterans.

<b><u>MEMBER</u></b>	<b><u>TERM EXPIRATION</u></b>	<b><u>ACTION</u></b>
<b>Jack Leonard, Ch.</b> 181 Happy Indian Ct. Southern Shores, NC 27949 252-255-4631 (H) <a href="mailto:Pljl12@embarqmail.com">Pljl12@embarqmail.com</a>	5/20	Apptd. 4/15 Reapptd. 5/17
<b>Steve Goodheart</b> 101 Trinitie Drive Duck, NC 27949 252-715-4577 (H) 703-861-5476 (Cell) stevegoodheart@gmail.com	5/19	Apptd. 7/18
<b>Russell Laney, Secretary</b> 412 Woodard Rd. Kitty Hawk, NC 27949 571-239-3054 (C) <a href="mailto:russobx@charter.net">russobx@charter.net</a>	5/21	Apptd. 6/16 Reapptd. 6/18
Norman B. St.Laurent 63 Hickory Trail Southern Shores , NC 27949 252-255-6383	5/21	Apptd. 5/18
Marsha Brown 163 Roanoke Trail Manteo, NC 27954 252-423-3007 (H) 252-202-2058 (C) <a href="mailto:giglineheroes@aol.com">giglineheroes@aol.com</a>	5/20	Apptd. 5/12 Reapptd.5/14, 5/20

Ellen Aidock 5/22 Apptd. 4/19  
521 Canal Drive  
Kill Devil Hills, NC 27948  
919-815-0977  
[ell2clif@yahoo.com](mailto:ell2clif@yahoo.com)

Blake Salmon 5/21 Apptd. 6/18  
25230 Bold Dune Drive, PO Box 705  
Waves, NC 27982  
(757) 869-2160  
[flyingfish577@gmail.com](mailto:flyingfish577@gmail.com)

Jack Shea (Ex-Officio) Apptd. 2/17  
Dare County Commissioner  
290 Wax Myrtle Trail  
Southern Shores, NC 27949  
252-261-4158 (H)

**NOTES:**

VAC was formed on 5/7/12.

**MEETING INFO:** 4<sup>th</sup> Thursday of each month, 3 p.m., Rm. 168, Dare County Administration Building, 954 Marshall C. Collins Dr., Manteo, NC

**CONTACT INFO:** Jack Leonard, Chair

**MEMBERS COMPENSATED:** No

Lynda Hester replaced Punk Daniels 6/13  
Billy Brown replaced Clarence Skinner 7/13  
Joshua Turner filled unexpired term of Pete Groom 3/14  
Jack Leonard filled vacant seat previously held by Joe Pope 4/15  
Gary Kierney replaced Josh Turner 4/15  
Charles Read, Jr. replaced Lynda Hester 6/16  
Russell Laney filled unexpired term of Dale Draper 6/16  
Carl Reiber filled unexpired term of Billy Brown 8/16  
Jeff Slaker filled unexpired term of Clarence Lewis who resigned 12/16  
Jack Shea added as Ex-Officio member from the DCBC 2/17.  
Kelli Rose Harmon filled unexpired term of Charles B. Read, Jr. who resigned 5/17.  
Frederick W. Lamm filled unexpired term of Jeff Slaker who resigned 10/17.

Norman St. Laurent replaced Frederick Lamm whose term expired and did not want to be reappointed 5/18

Blake Salmon replaced Gary Kierney 6/18

Steve Goodheart replaced Carl Reiber who resigned 7/18

The Veteran's Advisory Council requested that Jack Shea be appointed as "Counselor" to the Veteran's Advisory Council upon his retirement. This was approved by the DCBC – 11/18

Ellen Aidock replaced Kelli Harmon who resigned 4/19

**REVISED 4/19**





*Upcoming Board Appointments*

**Description**

The Dare County Board of Commissioners welcomes citizen participation on its many Boards and Committees.

Following is a list of the Boards and Committees that have terms expiring during the next 3 months. The list indicates when the item will be presented to the County Commissioners and any requirements that may pertain to the appointment.

Instructions on how to obtain and submit an application are attached along with additional information about each of the Boards and Committees with upcoming term appointments.

**Board Action Requested**

None

**Item Presenter**

Robert Outten, County Manager



## Upcoming Board & Committee Appointments

The Dare County Board of Commissioners welcomes citizen participation on Advisory Boards and Committees. This type of grassroots public involvement is the foundation of democracy and a vital part of maintaining Dare County as a quality place to live.

Following is a list of Boards and Committees that have terms expiring during the next 3 months. The list highlights when the item will be presented to the Board of Commissioners along with any special requirements that may pertain to the appointment.

Information about how to obtain and submit applications follows the list.

### June 2019

1. Albemarle Region Resource Conservation and Development Council (RC&D)  
The Albemarle Resource Conservation and Development Council, Inc. (ARCD) is a 501c3 non-profit organization serving the people of Camden, Chowan, Currituck, Dare, Gates, Hyde, Pasquotank, Perquimans, Tyrrell and Washington Counties. The Council assists local governments and community groups in northeast NC with projects that protect land and water resources while promoting economic development. 1 term expiring
2. Hatteras Community Center Board  
This Board operates and maintains the Hatteras Village Community Center. 3 terms expiring
3. Juvenile Crime Prevention Council (JCPC)  
As outlined and funded by the Juvenile Justice Reform Act of 1998, the Juvenile Crime Prevention Council assumes responsibility for assessing needs, funding community-based alternatives for troubled youth who enter the courts, and supporting prevention programs. 18 terms expiring
4. Land Transfer Tax Appeals Board  
This Board meets when someone disputes the amount of land transfer tax. 3 terms expiring
5. Library Board – Dare  
This Board establishes local policies within those set by the Regional Library Board and oversees the Library Trust Fund Budget, and also serve on the Board of the Dare County Library Foundation, a 501-C(3) tax- exempt organization. 1 term expiring
6. Manns Harbor Community Center Board  
This Board operates and maintains the community center facility and amenities for the use and benefit of Manns Harbor residents. 3 terms expiring
7. Roanoke Island Community Center Board  
This Board operates and maintains the Roanoke Island Community Center facility and amenities for the use and benefit of all members of the community. 4 terms expiring

8. Rodanthe, Waves, Salvo Community Center Board

This Board operates and maintains the Rodanthe, Waves, Salvo Community Center facility and amenities for the use and benefit of all members of the villages. 1 term expiring

9. Waterways Commission

The Dare County Waterways Commission advises the Board of Commissioners on inlets and waterways in Dare County. Working closely with community stakeholders, the U.S. Army Corps of Engineers, the Coast Guard, and State officials, the Commission endeavors to safeguard and assure access to Dare County's waterways.

3 terms expiring

**July 2019**

1. Airport Authority

The mission of the Dare County Airport Authority is to manage the operation, maintenance and improvement of air services and facilities for the use, convenience, and benefit of the air traveling public. 4 terms expiring

2. East Lake Community Center Board

Works to operate and maintain the East Lake Community Center for the use and benefit of all the residents of East Lake. 3 terms expiring

3. Game and Wildlife Commission

As set forth by State General Statute, the Dare County Game and Wildlife Commission issues and renews blind licenses for all Dare County waters, maintains a map and record system defining site locations and licensees, and also hears and reviews all licensing disputes. 3 terms expiring

4. Parks and Recreation Advisory Council

The Advisory Council reviews and advises the Department of Parks and Recreation in its efforts to promote, organize, plan and coordinate activities and programs for youth and adults in Dare County. 1 term expiring

5. Wanchese Community Center Board

This Board operates and maintains the Wanchese Community Center for the use and benefit of all members of the Wanchese community. 5 terms expiring

**August 2019**

1. ABC Board

The Dare County Alcoholic Beverage Control (ABC) Board manages the sale of distilled spirits by promoting excellence in customer service, fiscal responsibility, operational effectiveness, and compliance with laws that govern the sale and use of alcoholic beverages in Dare County. 1 term expiring

2. Dare County Center Advisory Board

The Advisory Board works to advise and promote goals and policies to enhance the Dare County Center's operations and community outreach. 4 terms expiring

3. Jury Commission

The Jury Commission consists of three members to certify jurors. One member is appointed by the Senior Regular Resident Superior Court Judge, one by the Clerk of Superior Court, and one by the Board of Commissioners. 1 term expiring

4. Stumpy Point Community Center Board

This Board operates and maintains the Stumpy Point Community Center facility and amenities for the use and benefit of all members of the Stumpy Point community. 4 terms expiring

**-----Instructions for Obtaining and Submitting Applications-----**

An application must be submitted in order for your name to be considered for a Board or Committee appointment. The form is available on the Dare County website, or by calling Janice Williams at 475-5800.

**COMMISSIONERS' BUSINESS**

**MANAGER'S / ATTORNEY'S BUSINESS**