



COUNTY OF DARE
PO Box 1000. MANTEO. NC 27954

DARE COUNTY BOARD OF COMMISSIONERS

Dare County Administration Building
954 Marshall C. Collins Dr., Manteo, NC

Monday, June 06, 2022

“HOW WILL THESE DECISIONS IMPACT OUR CHILDREN AND FAMILIES?”

AGENDA

- 9:00 AM CONVENE, PRAYER, PLEDGE OF ALLEGIANCE**
- ITEM 1** Opening Remarks - Chairman's Update
- ITEM 2** Service Pins - June, 2022
- ITEM 3** Employee of the Month
- ITEM 4** Public Comments
- ITEM 5** Red Shed LLC, Group Development Special Use Permit #4-2022
- ITEM 6** NC Division of Transportation
- ITEM 7** Community Care Clinic of Dare
- ITEM 8** Appropriation for Tourism Board Grant Match to Graveyard of the Atlantic Museum
- ITEM 9** Dare County Tourism Board Request Consent Expenditure from Long Term
Unappropriated Grant Fund Line Item 4585
- ITEM 10 Consent Agenda**
1. Approval of Minutes
 2. Required policies pertaining to expenditure of ARP/CSLFRF
 3. Amendment to Grant Project Ordinance for American Rescue Plan SLFRF Grant
 4. North Carolina U.N.C. Greensboro Grant Application "Dare County Sheriff's Office Regional Human Trafficking Task Force"
 5. NC Department of Transportation ADA Compliant Curb Ramps
 6. Avon Property Owners Association "Fourth of July" 2022 Fireworks Display
- ITEM 11 Board Appointments**
1. Virginia S. Tillett Community Center Advisory Board
 2. Wanchese Community Center
 3. Library Board - Dare
 4. Fessenden Center Advisory Board
 5. Game and Wildlife Commission
- ITEM 12 Commissioners' Business & Manager's/Attorney's Business**

ADJOURN UNTIL 5:00 P.M. ON JUNE 20, 2022



Opening Remarks - Chairman's Update

Description

Dare County Chairman Robert Woodard will make opening remarks.

Board Action Requested

Informational Presentation

Item Presenter

Chairman Robert Woodard, Sr.



Service Pins - June, 2022

Description

Service pins for the month of June will be presented

Board Action Requested

None

Item Presenter

Robert Outten, County Manager



Employee of the Month

Description

The Employee of the Month Certification will be presented.

Board Action Requested

None

Item Presenter

To Be Determined



Public Comments

Description

The Board of Commissioners encourages citizen participation and provides time on the agenda at every regularly scheduled meeting for Public Comments. This is an opportunity for anyone to speak directly to the entire Board of Commissioners for up to five minutes on any topic or item of concern.

Comments can be made at the Commissioners Meeting Room in Manteo (Administration Bldg., 954 Marshall Collins Drive, Manteo) or through an interactive video link at the Fessenden Center Annex (47013 Buxton Back Road, Buxton).

Board Action Requested

Hear Public Comments

Item Presenter

Robert Outten, County Manager



Red Shed LLC, Group Development Special Use Permit #4-2022

Description

Red Shed LLC has submitted a special use permit application to construct a group housing project consisting of 3 duplex structures for employee housing on Sand Street in Salvo Village. A detailed staff report and site plan for the proposal is attached with this cover sheet.

Board Action Requested

Motion to approve draft SUP and site plan--"I move that SUP #4-2022 and associated site plan for the proposed group development be approved."

Item Presenter

Noah H Gillam, Planning Director



County of Dare

P.O. Box 1000 | Manteo, North Carolina 27954 | 252.475.5000

May 12, 2022

MEMORANDUM

TO: DARE COUNTY BOARD OF COMMISSIONERS

FROM: Noah H Gillam, Planning Director 

RE: Proposed Group Development for Red Shed LLC

A Special Use Permit application has been submitted by Red Shed LLC for a proposed group housing project. The property is identified as parcel 013258001 on the Dare County Tax Records. The property is zoned S-1 and group developments are allowed in this district subject to review as a special use, as referenced in 22-31 of the Dare County Zoning Ordinance. The parcel is 20,100 square feet and meets the minimum lot size required for a group development.

There are currently two existing dwellings on the parcel that the applicant is proposing to remove. The applicant is proposing to construct three duplex structures that will serve as employee housing. Two of the structures will contain two units each with 2-bedrooms and the third will contain two 3-bedroom units. The proposed site plan shows the dwellings being separated by 20.5 feet meeting the requirements of the group development ordinance.

Each structure in the group development will be accessed directly off of Sand St (S.R. 1532). Driveway permits or approvals will need to be obtained from NCDOT and provided to the Dare County Planning Department before construction activities can occur. The site plan has been reviewed by the fire marshal, and his comments are attached to this memo. Conditions have been added to the draft SUP to address these topics.

A final site plan of the group development depicting footprint areas shall be recorded in the Register of Deeds. Units in the group development may be transferred to individual owners with the remainder of the site dedicated as common area owned by a homeowners association or other similar entity. A copy of the signed special use permit shall be recorded with the final site plan.

The proposal was reviewed by the Dare County Planning Board at their May 09, 2022 meeting. The conditions in the draft SUP and site plan were identified by the Planning Board and recommended as reasonable and appropriate conditions to apply to the proposed use. A copy of the site plan and draft SUP are attached to this memo for the boards review.

The notice procedures for quasi-judicial uses established in Section 22-72 of the Dare County Zoning Ordinance were implemented.

Draft Motion: "I move that SUP #4-2022 and associated site plan for the proposed group development be approved."



Special Use Permit No. #4-2022

Dare County Sections 22-27.1, 22-31, 22-65, & 22-70

Application of: Red Shed, LLC

On June 06, 2022 the Dare County Board of Commissioners considered the application of the Petitioner above named which application is on file with the Dare County Planning Department, and the Board finds as follows:

1. That the written application of Petitioner with attachments has been duly submitted to the Dare County Planning Department as required by Section 22-65 of the Dare County Code (hereinafter referred to as "Code");
2. That the application substantially complies with the requirements of the Code in that it requests uses permitted by special use permit under the Code subject to the quasi-judicial procedures set forth in Section 22-70, including; Group Developments
3. The subject property is zoned S-1. This property is identified on the Dare County tax records as PARCEL 013258001 and located in the Salvo Tax District.
4. That the Dare County Board of Commissioners is empowered under sections of the Code set out above to approve special uses and apply reasonable and appropriate conditions;
5. That the notice procedures of Section 22-72 of the Code have been implemented in the review of this Special Use Permit;
6. That upon the evidence received, the testimony presented, and the submitted written record, there are sufficient facts to support the issuance of this Special Use Permit according to the following terms and conditions:

SPECIAL USE: A Group Development consisting of 3 residential duplex structures. A site plan depicting the proposed improvements identified as Appendix B is included as part of this permit.

CONDITIONS:

1. The group development shall operate as prescribed in the definition set forth in Section 22-31 of the Dare County Zoning Ordinance. The structures shall be constructed as depicted on the Appendix B.
2. All structural improvements shall be located in the dwelling footprints as recorded on the final plat.
3. The structures shall be located on the parcel in conformance with the setbacks of Section 22-27.1 and Section 22-31 of the Zoning Ordinance and the Dare County Flood Damage Prevention Ordinance.
4. A final site plan of the group development depicting the footprint areas shall be recorded in the Register of Deeds. The dwelling units may be transferred to individual owners with the remaining area of the site dedicated as common area owned by a homeowners association or other similar entity. A copy of the signed special use permit shall be recorded with the final site plan.
5. Building permits for the structures shall be secured within 36 months from date of Board of Commissioners approval. An as-built survey for the property shall be submitted to the Planning Department upon the completion of all of the structures to confirm compliance with the terms of the Dare County Zoning Ordinance. If the developer chooses to construct the structures at different times, then individual as-built surveys for each structure shall be required before any structure is certified for occupancy.
6. All structures shall be constructed in compliance with the requirements of the Dare County Fire Marshal and North Carolina Fire Code.
7. Driveway permits or approvals from NCDOT shall be provided to the Planning Department before building permits will be issued.
8. There shall be no staging of equipment or materials in or along the right-of-way of Sand St.
9. No changes or deviation from the terms and conditions of the special use approval shall be made until written approval of the proposed changes or deviations has been obtained from Dare County. The quasi-judicial procedures set forth in the Code shall be followed for the review and approval of major modifications. Minor modifications as established in Section 22-70 of the Code may be authorized administratively by the Planning Director.
10. A violation of this Permit shall be a violation of the Code and the special use may be revoked by the Board of Commissioners. Special use approval shall be revoked for any

substantial departure from the approved application, plans, or specifications; for refusal or failure to comply with the requirements of any development regulation or any State law delegated to Dare County for enforcement purposes; or for false statements or misrepresentations made in securing special use approval. The same process for approval of a special use permit, including notice and hearing, shall be followed in the revocation of a special use permit.

11. All other terms and provisions of the Dare County Zoning Ordinance shall remain in full force and effect except as herein specifically permitted otherwise;

This 6th day of June 2022

SEAL:

COUNTY OF DARE

By: _____

Robert L Woodard Sr.
Dare County Board of Commissioners

ATTEST:

By: _____

Cheryl Anby
Clerk to the Board

THIS PERMIT AND THE CONDITIONS HEREIN ARE ACCEPTED

By: _____

Red Shed, LLC

APPROVED AS TO LEGAL FORM

By: _____

Robert L Outten
County Attorney

SITE PLAN NOTES

- OWNER: RED SHED, LLC
PO BOX 478
WILCOX, NC 27573
- THE OWNER INTENDS TO CONSTRUCT THREE 3-STORY DUPLEX RESIDENTIAL STRUCTURES WITH PARKING (SEVEN CHARGED SPACES). THE ACCESSIBLE AREAS INTENDED FOR EMPLOYEE / WORKFORCE HOUSING.
- THE PROPERTY IS SITE 2 OF A PARCEL SURVEYED BY JEAN ANTOINE OUCHAL, P.E., M.S., JEA, REGISTERED IN B.S. 2344, NC 172. DATE CONVEYED FROM 04/10/20 TO 01/07/20. DATE CO. MAPS, IN. 01/31/2014. PROJECT NUMBER: 27221 A SAND ST., SAND, NORTH CAROLINA.
- THE SITE IS LOCATED IN FIRM ZONE SPOC-4 FIRM MAP NUMBER 2702000000. EXISTING SITE PLAN IS 2000 SUBJECT TO CHANGE BY FIRM.
- ALL DISTANCES ARE MEASURED ALONG GROUND DISTANCES UNLESS OTHERWISE SPECIFIED. ELEVATIONS SHOWN ARE HEREIN FOR VERTICAL.
- AREAS SHOWN ARE IN COORDINATE METHOD.
- EXISTING ELEVATIONS AND SURVEY INFORMATION PROVIDED BY J. H. WALKER LAND SURVEYOR, SURVEY INFORMATION OBTAINED ON FEBRUARY 12, 2022.
- THERE ARE NO DECLARED WETLANDS ON THE PROJECT SITE.
- THE PROPERTY IS ZONED S-1 AND GROUP DEVELOPMENTS / GROUP WETLANDS PROJECTS ARE A SPECIAL USE.
- PARKING REQUIREMENTS:
DUPLEX (2 UNITS WITH 2 BEDROOMS EACH UNIT) = 4 PARKING SPACES
DUPLEX (1 UNIT WITH 3 BEDROOMS EACH UNIT) = 2 PARKING SPACES PROVIDED.
- SETBACKS:
FRONT: 25' (ARTICLE 22-27.12.4)
SIDE: 5 FEET (ARTICLE 22-31.1.C.1)
REAR: 25' (ARTICLE 22-31.1.C.1)
SEPARATION OF STRUCTURES: 20' (ARTICLE 22-39.8.B)
- CREOSOTE AREA:
PARKING AREA = 2,300.00 SF (66.44 ACRES)
(EXCLUDES PARKING WETLANDS)
BUILDING AREA = 3,274.00 SF (0.074 ACRES)
(EXCLUDES BODIES)
OTHER AREA = 1,848.58 SF (0.042 ACRES)
- AREA TO BE DEMOLISHED: 20,000 SF (0.46 ACRES)
- LOT AREA: 20,000.00 SF
ALLOWABLE COVERAGE = 8,000.00 SF (20% - ARTICLE 22-37.12.3)
- COVERAGE IS AS FOLLOWS:
EXISTING STRUCTURES = 1,235.00 SF
GRAVEL = 579.00 SF
(EXISTING STRUCTURES TO BE DEMOLISHED)
PROPOSED:
STRUCTURES = 3,274.00 SF
DRIVEWAYS = 2,500.00 SF
PARKING = 2,300.00 SF (0.074 ACRES)
- SEE FENCE TO BE INSTALLED ON SITE AS SHOWN ON LOCATION AND EROSION CONTROL PLAN.
- WATER SERVICES SHALL BE COORDINATED WITH THE DADE COUNTY WATER DEPARTMENT. CONSTRUCTION OF SERVICE MAY BE TO PROVIDE SEVERAL SERVICES TO EACH UNIT, A SINGLE SERVICE FOR EACH STRUCTURE, OR A SINGLE WATER METER FOR THE SITE.

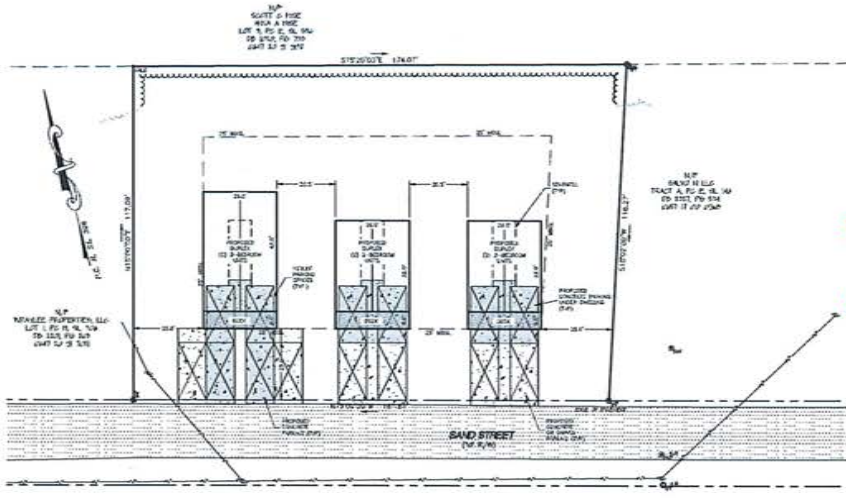

**FINAL DRAWING
NOT FOR
CONSTRUCTION**

LEGEND

Symbol	DESCRIPTION
Symbol	CALCULATED POINT
Symbol	IRON PIPE FOUND
Symbol	NON IRON FOUND
Symbol	PIPE FOUND
Symbol	R/W MONUMENT FOUND
Symbol	RIGHT OF WAY
Symbol	PROPERTY BOUNDARY
Symbol	ADJACENT PROPERTY LINE
Symbol	EXISTING POWER POLE
Symbol	OVERHEAD ELECTRIC
Symbol	EXISTING CABLE TV PEGS/POSTS
Symbol	EXISTING FIRE HYDRANT
Symbol	EXISTING WATER METER
Symbol	PROPOSED WATER METER
Symbol	EXISTING WATERLINE
Symbol	PROPOSED SANITARY TANK
Symbol	PROPOSED SANITARY CLEANOUT
Symbol	EXISTING CONTROLS
Symbol	PROPOSED CONTROLS
Symbol	EXISTING SPOT ELEVATIONS
Symbol	PROPOSED SPOT ELEVATIONS
Symbol	EXISTING PRESSURE
Symbol	PROPOSED TRENCH
Symbol	1/4" BENCH
Symbol	LIMITS OF DISTURBANCE

- I. NARRATIVE**
- RED SHED USE INTENDS TO DEMOLISH TWO EXISTING DUPLEXES AT 27221 A SAND STREET AND CONSTRUCT THREE DUPLEXES AS EMPLOYE WORKING HOUSING. A SINGLE SERVICE TO EACH UNIT, A SINGLE SERVICE FOR EACH STRUCTURE, OR A SINGLE WATER METER FOR THE SITE.
- THE SITE IS ZONED S-1 AND GROUP DEVELOPMENTS / GROUP WETLANDS PROJECTS ARE A SPECIAL USE.
- DEMOLITION AREAS ARE TO BE DEMOLISHED WITH DEMONSTRATION/PERMANENT SECTORIZATION ACCORDING TO THE SEQUENCE OF CONSTRUCTION.

- II. SOIL DESCRIPTION**
- SOIL TYPES AS SHOWN IN THE SOIL SURVEY OF DADE COUNTY:
- COLEMAN FINE SAND (C-8)
- III. CONSTRUCTION SEQUENCE**
- OBTAIN SITE PLAN APPROVAL
 - OBTAIN ALL NECESSARY ENVIRONMENTAL PERMITS
 - PLACE OF STAKE MARK UNITS / PROPERTY LINES
- PHASE ONE**
- INSTALL 36" FENCE AS SHOWN ON THE SITE PLAN
 - CLEAR LOT OF EXISTING STRUCTURES AND LOCATION AS SHOWN
 - REMOVE SEPTIC SYSTEM
- PHASE TWO**
- STRIP 6" TOPSOIL FROM GRAVELLY FILL AREAS
 - PLACE AND GRADE FILL MATERIALS
 - ESTABLISH TEMPORARY VEGETATION ALONG ANY AREAS REQUIRED IN ACCORDANCE WITH THE "DEMOLITION AND EROSION CONTROL" MANUAL
 - COMMENCE CONSTRUCTION OF NEW STRUCTURE AND SEPTIC SYSTEM
 - CONSTRUCT NEW DRIVEWAYS
 - ESTABLISH PERMANENT VEGETATION ON ALL DISTURBED AREAS ON PROPERTY AND ADJACENT NEIGHBORHOODS
 - REMOVE AND REPAIR DISTURBED AREAS UNLESS PERMANENT RESTORATION IS FEASIBLE AND APPROVED AND STABILIZATION IS ACHIEVED
 - REMOVE 36" FENCE

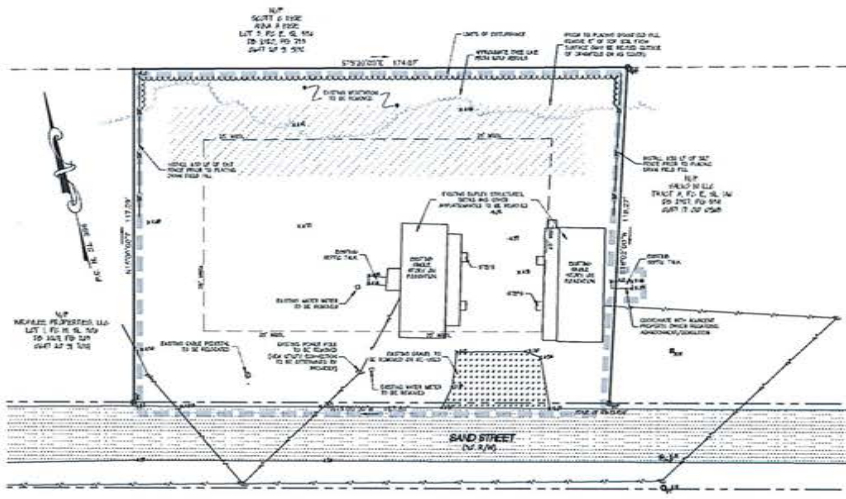

- V. DEMOLITION NOTES**
- ALL EXISTING IMPROVEMENTS SHOWN WITHIN THE LIMITS OF DISTURBANCE SHALL BE REMOVED UNLESS SPECIFICALLY NOTED TO REMAIN. THE CONTRACTOR SHALL BE RESPONSIBLE FOR PROPER DISPOSAL TO AN OFFICE LOCATION PROVIDED BY THE AGENCIES.
- CONTRACTOR SHALL TAKE ALL NECESSARY PRECAUTIONS TO CAREFULLY REMOVE ALL ITEMS SHOWN TO BE REMOVED PRIOR TO REMOVAL AND CONSIDER THE PROTECTIVE COVERING OF EXISTING UTILITIES TO THE FIRM SHALL BE REQUIRED TO THE OWNER IMMEDIATELY. CONTRACTOR SHALL BE RESPONSIBLE FOR THESE CHARGES DURING THE PROJECT.
- WARNING**
- LOCATION OF EXISTING UNDERGROUND UTILITIES IS UNKNOWN AND HAS NOT BEEN SHOWN ON THESE DRAWINGS. ALL UNDERGROUND UTILITIES DISCOVERED SHALL IMMEDIATELY BE REPORTED TO THE OWNER.
- SEPTIC SYSTEM ARRANGEMENT NOTES**
- SEE SEPTIC SYSTEM IMPROVEMENT PLAN FOR ANY ADDITIONAL CONDITIONS.
 - INSTALL AN APPROVED WETLAND PUMP TO REMOVE ANY REMAINING UGDS, SOLIDS, AND SOLID FROM SANDS TO BE REMOVED/REMOVED.
 - REMOVE TANKS AND PROPERLY DISPOSE OF REMAINS AT AN AUTHORIZED WETLAND. TANKS SHOULD BE REMOVED AND BACKFILLED WITH CLEAN FILL FROM AN APPROVED SOURCE.
 - REMOVE EXISTING GRANULAR MEDIA SANDFILLS SHOWN TO BE REMOVED. REMOVE SANDS EXISTING WITH SANDFILLS SHOWN TO BE APPROVED.
 - BACKFILLED AREAS SHALL BE COMPACTED TO A MINIMUM OF 95% DENSITY. MORE STRINGENT COMPACTOR REQUIREMENTS MAY APPLY WITHIN THE PROJECT SPECIFICATIONS.
 - UPON COMPLETION OF REMOVAL, BACKFILL, AND DISPOSAL OF ALL EXISTING UTILITIES SHALL BE COVERED WITH HYDRATED LIME OR EXPOSED TO EROSION AND A VEGETATION COVER SHALL BE ESTABLISHED.

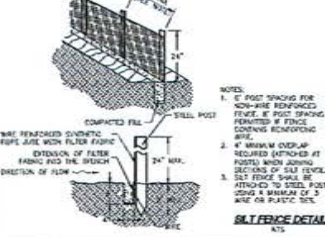

SITE STABILIZATION REQUIREMENTS

SITE AREA DESCRIPTION	STABILIZATION TIME FRAME	STABILIZATION TIME FRAME EXCEPTIONS
PERIMETER DITCH, CHANNELS AND SWALES	7 DAYS	NONE
NON QUALITY WATER (NOW) ZONES	7 DAYS	NONE
GRAVEL STRIPPER OVER 2"	7 DAYS	IF STRIPPER ARE NOT ON LOTS IN LENGTH AND ARE NOT STIPPER THEN 2.5' IN OVER ARE ALLOWED
SLOPES 3:1 OR FLATTER	14 DAYS	3-DAY FOR SLOPES GREATER THAN 3:1 IN LENGTH
ALL OTHER AREAS WITH SLOPES GREATER THAN 4:1	14 DAYS	NONE (EXCEPT FOR PERIMETER AND NON-QUALITY)

DATE: 04/15/2022
DRAWN BY: JAC WYBES
CHECKED BY: MAM
SCALE: 1" = 20'
PROJECT NO: 08602A

Albemarle & Associates, L.P.
Engineering - Environmental - Land Planning

REVISIONS

NO.	DATE	DESCRIPTION

SITE PLAN AND DEMOLITION PLAN
RED SHED, LLC
27221 A SAND STREET

DADE COUNTY
WILCOX TOWNSHIP
SAND

DATE: 04/15/2022
DRAWN BY: JAC WYBES
CHECKED BY: MAM
SCALE: 1" = 20'
PROJECT NO: 08602A

- GRADING NOTES**
- PROOF TO COMPLETION OF ANY LAND DISTURBING ACTIVITIES, ALL EROSION AND SEDIMENTATION CONTROL MEASURES IDENTIFIED ON THIS PLAN SHALL BE INSTALLED IN ACCORDANCE WITH THE EROSION CONTROL PLAN.
 - THE EROSION CONTROL MEASURES SHALL BE MAINTAINED THROUGHOUT THE CONSTRUCTION PERIOD AND SHALL BE MAINTAINED THROUGHOUT THE LIFE OF THE PROJECT. THE EROSION CONTROL MEASURES SHALL BE MAINTAINED THROUGHOUT THE LIFE OF THE PROJECT.
 - LIMITS OF GRADING AND GRADING SHALL BE IN ACCORDANCE WITH THE LIMITS SHOWN HEREON.
 - EXISTING FEATURES AND SURVEY INFORMATION PROVIDED BY J. H. MILLER LAND SURVEYING, SURVEY INFORMATION DATED ON FEBRUARY 11, 2022, ELEVATION ME PER 1/10/22.

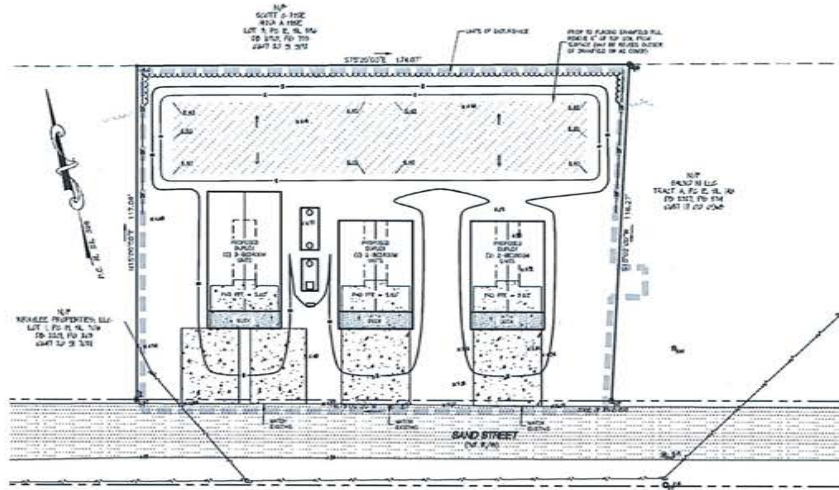

GRADING PLAN
SCALE: 1" = 20'

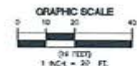

SEEDING SCHEDULE

AREA 1 - ALL B PERMANENT BEDDING

SPECIES	RATE
K-11 FESCUE	3 LB/1000 SF
COMMON BROMUSGRASS	1 LB/1000 SF
AMBER EYE GRASS	2 LB/1000 SF

NOTE: DELETE THE GRASS IF OVERSEEDING ESTABLISHED BY OR REMOVE. DELETE PERMANENT IF OVERSEEDING ESTABLISHED FESCUE.

AREA 2 - ALL B PERMANENT BEDDING

SPECIES	RATE
K-11 FESCUE	3 LB/1000 SF
COMMON BROMUSGRASS	1 LB/1000 SF
AMBER EYE GRASS	2 LB/1000 SF

NOTE: DELETE THE GRASS IF OVERSEEDING ESTABLISHED BY OR REMOVE. DELETE PERMANENT IF OVERSEEDING ESTABLISHED FESCUE.

AREA 3 - ALL B PERMANENT BEDDING

SPECIES	RATE
K-11 FESCUE	3 LB/1000 SF
COMMON BROMUSGRASS	1 LB/1000 SF
AMBER EYE GRASS	2 LB/1000 SF

NOTE: DELETE THE GRASS IF OVERSEEDING ESTABLISHED BY OR REMOVE. DELETE PERMANENT IF OVERSEEDING ESTABLISHED FESCUE.

SOIL AMENDMENT

SPECIES: NONE

RATE: NONE

NOTE: USE A-T-C. CALCULATE AMOUNT OR OTHER SPECIFIC CHARGES USING MATERIAL TO COVER BOTTOM AND SIDES OF CHANNELS. AMOUNTS LISTED PER MANUFACTURER'S RECOMMENDATIONS. AMOUNTS LISTED ARE AN ACCEPTABLE METHOD OF TEMPORARY STABILIZATION.

NOTES

1. A MINIMUM OF 3 WEEKS IS REQUIRED TO FOR ESTABLISHMENT, INSPECT AND REPAIR SOILS FREQUENTLY. REPEATE THE FOLLOWING SCHEDULE WITH 30 DAY A-T-C INTERVALS.

FINAL DRAWING
NOT FOR
CONSTRUCTION

- LPP SEPTIC SYSTEM NOTES**
- THE SITE IS LOCATED AT 27221 SAND STREET, SANDY, NC.
 - THE DESIGN FLOW IS 1600 GPD BASED UPON THE FOLLOWING:
(1) 2-BEDROOM UNIT = (12000 GPD) = 800 GPD
(2) 3-BEDROOM UNIT = (12000 GPD) = 700 GPD
TOTAL = 1500 GPD
 - THE LPP DRAINFIELD SHALL INCLUDE (2) DRAINFIELDS, EACH WITH (3) 4.5 LF LPP DRAINAGES AT 2' D.C. FOR A TOTAL DRAINFIELD AREA OF 3.375 OF 4' AND A PRESSURE LOADING RATE OF 45.0 GPD/FT².
 - SYSTEM SHALL BE CONSTRUCTED IN ACCORDANCE WITH SEWER RULES SECTION 15 NCAC 15A.000 CURRENT EDITION.
 - LPP FIELDS ARE TO OPERATE @ 3.0' PRESSURE HEAD AT ENDS OF LATERALS.
 - ALL EXISTING FIELDS ARE MATERIAL SHALL COME FROM A PRE-APPROVED SOURCE.
 - THE CONTRACTOR SHALL VERIFY ALL DIMENSIONS AND SHALL NOTIFY NC-ONE-CALL PRIOR TO CONSTRUCTION (2 WORKING DAYS).
 - HORIZONTAL AND VERTICAL ORIENTATION OF EXISTING UNDERGROUND UTILITIES ARE NOT KNOWN. THE CONTRACTOR SHALL VERIFY ALL LOCATIONS OF ALL EXISTING UTILITIES PRIOR TO CONSTRUCTION OF CONSTRUCTION.
 - THE CONTRACTOR SHALL SUBMIT A LIST OF MATERIALS FOR APPROVAL TO THE ENGINEER PRIOR TO COMMENCEMENT OF CONSTRUCTION.
 - INSPECTION DURING CONSTRUCTION WILL BE PROVIDED BY THE ENGINEER AND SAND COUNTY HEALTH DEPARTMENT. THESE INSPECTIONS DO NOT RELIEVE THE CONTRACTOR FROM HIS OBLIGATION AND RESPONSIBILITY FOR CONSTRUCTING THE SYSTEM IN STRICT ACCORDANCE WITH THE PROJECT PLANS AND SPECIFICATIONS.
 - THE CONTRACTOR SHALL COMPLY WITH ALL APPLICABLE STATE, FEDERAL, LOCAL, AND LOCAL HEALTH DEPARTMENT. ANY FIELD CHANGES TO THE PLANS SHALL BE APPROVED BY THE ENGINEER AND LOCAL HEALTH DEPARTMENT AND SHALL BE ACCURATELY RECORDED ON THE AS-BUILT DRAWINGS.
 - ALL COMPONENTS OF THE SYSTEM SHALL BE INSTALLED AND TESTED IN ACCORDANCE WITH THE CONTRACT SPECIFICATIONS, AND THESE PLANS. AFTER TESTING IS COMPLETED AND ALL COMPONENTS OF THE SYSTEM ARE INSTALLED AND TESTED BY THE CONTRACTOR, THE CONTRACTOR SHALL SUBMIT AS-BUILT DRAWINGS TO THE COUNTY HEALTH DEPARTMENT AND INSPECTION WITHIN 30 DAYS OF COMPLETION OF THE AS-BUILT DRAWINGS.
 - THE CONTRACTOR SHALL SUBMIT A LIST OF MATERIALS FOR APPROVAL TO THE ENGINEER PRIOR TO COMMENCEMENT OF CONSTRUCTION.
 - SYSTEM SHALL BE CONSTRUCTED IN ACCORDANCE WITH SEWER RULES SECTION 15 NCAC 15A.000 CURRENT EDITION.
 - INSPECTION DURING CONSTRUCTION WILL BE PROVIDED BY THE ENGINEER AND SAND COUNTY HEALTH DEPARTMENT. THESE INSPECTIONS DO NOT RELIEVE THE CONTRACTOR FROM HIS OBLIGATION AND RESPONSIBILITY FOR CONSTRUCTING THE SYSTEM IN STRICT ACCORDANCE WITH THE PROJECT PLANS AND SPECIFICATIONS.
 - ALL WINDPIPE RISERS SHALL BE WATER-TIGHT, CONFORM TO NORTH CAROLINA CODE 15A NCAC 15A.000 AND BROUGHT TO FINISH GRADE BY CONSTRUCTION, UNLESS OTHERWISE NOTED.
 - ALL TANK HEADS AND OUTLETS SHALL BE FITTED WITH PRESSURE RISERS.
 - ALL TANK DIMENSIONS INCLUDING INLET/OUTLET LOCATIONS AND INSET ELEVATIONS SHALL BE FIELD VERIFIED PRIOR TO INSTALLATION.
 - NO MODIFICATIONS TO THIS PLAN SHALL BE MADE WITHOUT THE PRIOR APPROVAL OF THE ENGINEER AND LOCAL HEALTH DEPARTMENT. ANY FIELD CHANGES TO THE PLANS SHALL BE APPROVED BY THE ENGINEER AND LOCAL HEALTH DEPARTMENT AND SHALL BE ACCURATELY RECORDED ON THE AS-BUILT DRAWINGS.
 - ALL COMPONENTS OF THE SYSTEM SHALL BE INSTALLED AND TESTED IN ACCORDANCE WITH THE CONTRACT SPECIFICATIONS, AND THESE PLANS. AFTER TESTING IS COMPLETED AND ALL COMPONENTS OF THE SYSTEM ARE INSTALLED AND TESTED BY THE CONTRACTOR, THE CONTRACTOR SHALL SUBMIT AS-BUILT DRAWINGS TO THE COUNTY HEALTH DEPARTMENT AND INSPECTION WITHIN 30 DAYS OF COMPLETION OF THE AS-BUILT DRAWINGS.
 - ALL DISTURBED SOIL SHALL BE STABILIZED AS SOON AS POSSIBLE BY GRADING AND SEEDING.

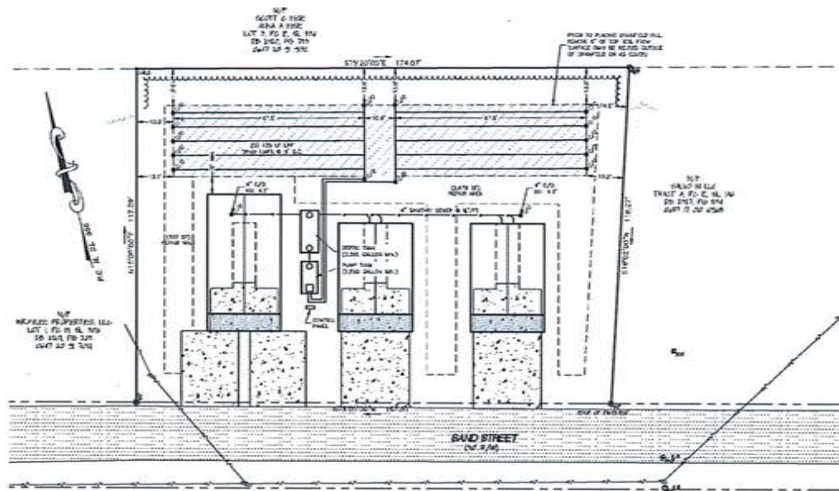

LPP SEPTIC SYSTEM PLAN
SCALE: 1" = 20'

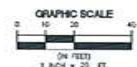

SEE SHEET C401 FOR SEPTIC SYSTEM DETAILS

LEGEND

●	CALCULATED POINT
○	IRON PIPE FOUND
○	IRON ROD FOUND
○	PC WALL FOUND
○	R/W MOVEMENT FOUND
---	POINT OF VIEW
---	PROPERTY BOUNDARY
---	ADJACENT PROPERTY LINE
○	EXISTING POWER POLE
○	OVERHEAD CABLE
○	EXISTING CABLE TO FEDERAL
○	EXISTING FIRE HYDRANT
○	EXISTING WATER METER
○	PROPOSED WATER METER
○	EXISTING WATERLINE
○	PROPOSED WATERLINE
○	PROPOSED SANITARY CLEANOUT
○	EXISTING CONDUITS
○	PROPOSED CONDUITS
○	EXISTING SPOT ELEVATIONS
○	PROPOSED SPOT ELEVATIONS
○	EXISTING TREELINE
○	PROPOSED TREELINE
○	SAT FINISH
○	LIMITS OF DISTURBANCE



REVISIONS

NO.	DATE	DESCRIPTION
1	03/27/2022	ISSUED FOR PERMIT

GRADING PLAN AND SEPTIC PLAN
RED SHED, LLC
27221 A SAND STREET
SANDY, NC 27055
DADE COUNTY
NORTH CAROLINA

DATE: 03/27/2022
DRAWN BY: SEE NOTES
CHECKED BY: []
DESIGNED BY: []
SCALE: 1" = 20'
PROJECT NO: 08602A

DRAINFIELD DESIGN PARAMETERS

Q = 1,833 GPD
 DRAINFIELD = (5 UNITS) (135 LF/LINE) = 675 LF
 TOTAL DRAIN FIELD AREA = (675 LF) (5 SF/LF) = 3,375 SF
 LOADING RATE = 1,833 GPD / 3,375 SF = 0.55 GPD/SF
 FIELDS SET TO OPERATE @ 3 SF HEAD (6" HOLES = 0.5 GPD/HOLE)
 PUMP RATE = (675 LF/2 (DRAINFIELD)) (1 HOLE/S LF) (0.5 GPD/HOLE) = 84 GPM
 3" MANIFOLD (6"x7.25" RT)
 (5) 1 1/4" LATERAL TEE (A = 6.14 IN.)
 MSD = 1.15:1

**FINAL DRAWING
 NOT FOR
 CONSTRUCTION**

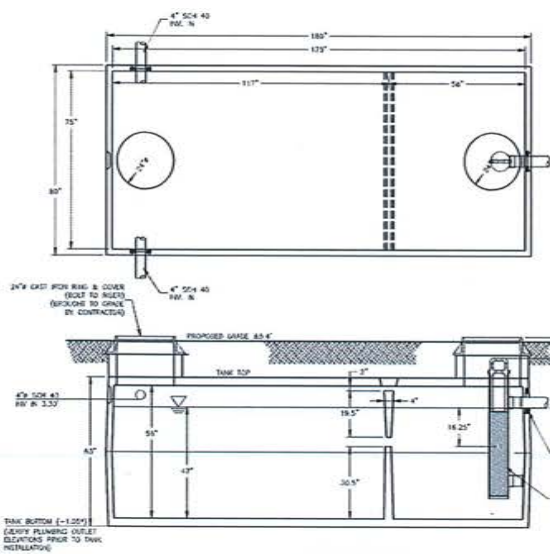

TANK BOTTOM (-1.25')
 (SHOW FRAMING JOIST
 ELEVATIONS PRIOR TO TANK
 INSTALLATION)

2000 GALLON SEPTIC TANK
 2,000 GALLON MIL. SEPTIC TANK
 (2,000 GALLON CAP-200-200 SHOWN)
 @ APPROVED EQ. #

(* NOTE: ALL DIMENSIONS, INVERTS, ELEVATIONS ARE
 BASED UPON TANK MODEL NOTED IN DETAILS. IF ANOTHER
 TANK IS USED, PROVIDE PLAN REVISIONS FOR ENGINEER'S
 APPROVAL BEFORE ORDERING MATERIAL.

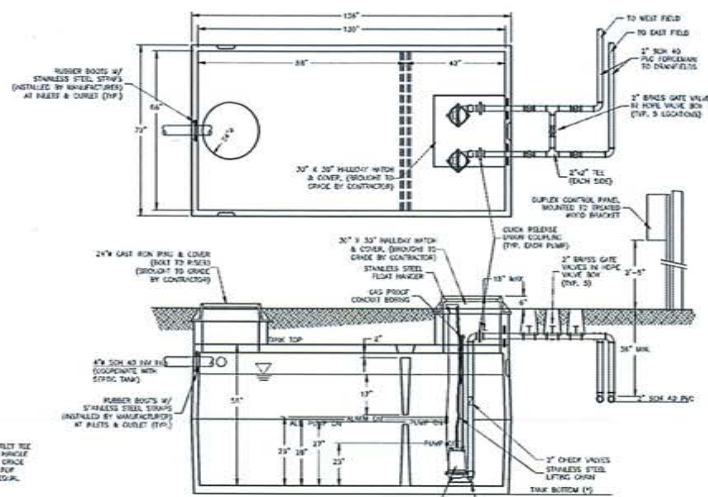

1800 GALLON PUMP TANK
 1,800 GALLON MIL. PUMP TANK
 (1,800 GALLON CAP-17-475 SHOWN)
 @ APPROVED EQ. #

(* NOTE: FIELDS MUST BE HAND FROM A FIBER
 OPTIC OR ROOF BY SUCH A POSITION THAT THE
 PUMPS AND PIPING DO NOT INTERFERE WITH
 BREAK REPAIRS. TRUCK TIE MAY BE USED.

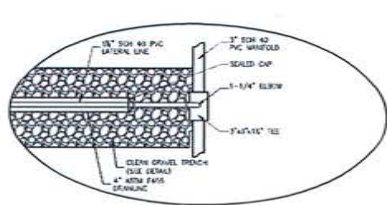

SINGLE FEED MANIFOLD DETAIL
 NTS

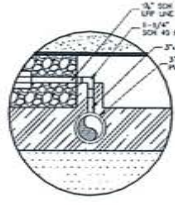

SINGLE FEED MANIFOLD SECTION
 NTS

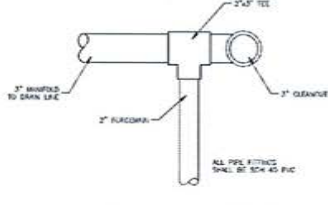

FORCE MAIN TO MANIFOLD CONNECTION DETAIL
 NTS

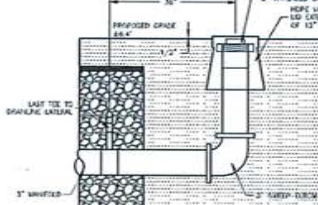

MANIFOLD CLEAN OUT DETAIL
 NTS

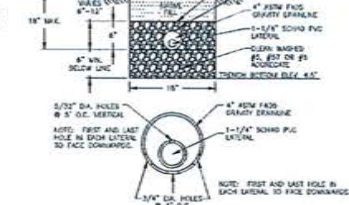

LPP TRENCH DETAIL
 NTS

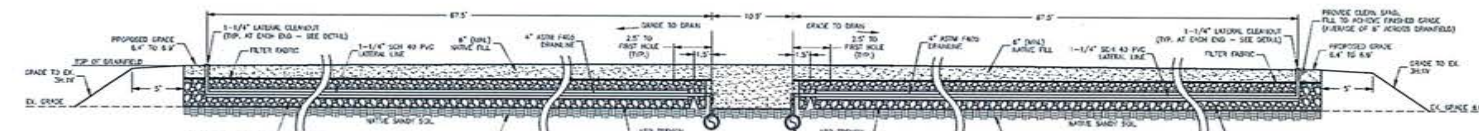

LPP DRAINFIELD CROSS SECTION
 NTS

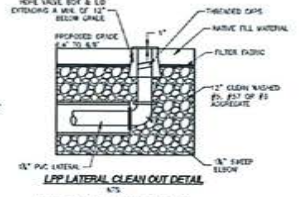

LPP LATERAL CLEAN OUT DETAIL
 NTS

NOTE: FIBER OPTIC INSTALLATION MUST BE
 PROVIDED AT THE END OF ALL LATERALS.

Albemarle & Associates, Ltd.
 Engineering - Environmental - Land Planning
 1100 West 12th Street, Suite 101
 White Plains, NY 10614
 Tel: 914.261.2000
 Fax: 914.261.2001
 Email: info@albemarle.com
 www.albemarle.com



REVISIONS

NO.	DATE	DESCRIPTION

WASTEWATER DETAILS
RED SHED, LLC
 27221 A SAND STREET
 NORTH CAROLINA
 WAKE COUNTY
 SAUCO
 MINNETT TOWNSHIP

SCALE: AS SHOWN
C401
 PROJ. NO. 080820A



COUNTY OF DARE
Department of Emergency Management
Office of the Fire Marshal
P.O. Box 1000, Manteo, North Carolina, 27954

Steven R. Kovacs, NC-CFI
Deputy Emergency Manager/Fire Marshal

(252) 475-5750

To: Noah Gilliam, Planner Director
From: Steven R. Kovacs, Fire Marshal
Date: April 25, 2022
Re: 27221 A Sand Street – Red Shed LLC

I have reviewed the submitted site plan for the cluster home project at the noted address and have the following comments.

- This office conducted a recent waterflow test of the only fire hydrant located on Sand Street just east of this project's location within the needed distance for the Fire Code. The results of the test indicated that the fire hydrant is capable of flowing 876 gallons per minute.
- The needed fire flow for the large structure was calculated at 1,000 gallons per minute. This was figured based on a 2-hour rated firewall between the two units (ground to roof) reducing the overall square footage to 1,872 per unit to include parking underneath the structure. A second calculation was made to provide credit for the installation of an automatic sprinkler system. With this credit, the needed fire flow was reduced to 750 gallons per minute which would meet the needed Fire Code requirements.
- The small units were calculated with the 2-hour rated firewall in between from ground to roof line. Per unit the overall square footage was figured to be 1,482 square feet. This resulted in the needed fire flow to be 750 gallons per minute which was within the Fire Code requirements.
- I have no issue with the small units at the present time as long as the fire walls are installed. The concern is the large units. The only way that I can approve with project as currently proposed is if the large units have a Fire Code compliant sprinkler system installed.

If you have any questions please let me know.

** Please understand that approval of any documents in no way relieves the owner, the architect, the engineer, or the contractor from the responsibility of violations of governing codes and regulations not found by our office. When such violations are found they must be corrected.*



NC Division of Transportation

Description

Members of the NC Division of Transportation will present an update to the Board.

Board Action Requested

None - Presentation

Item Presenter

CW. "Win" Bridgers, Ronald K. Sawyer and Gretchen Byrum



Community Care Clinic of Dare

Description

Community Care Clinic of Dare provides basic healthcare, medication assistance and wellness education for financially challenged and uninsured persons living or working in Dare County.

Board Action Requested

Presentation to the Board

Item Presenter

Lyn Jenkins, RN BSN, Executive Director



Appropriation for Tourism Board Grant Match to Graveyard of the Atlantic Museum

Description

The Tourism Board has approved a grant of \$250,000 to the Friends of the Graveyard of the Atlantic Museum for completion of a project funded in the 2022 State budget. The award is conditional upon approval by the Board of a \$250,000 match to the grant. Approval of the Tourism Board grant award is the next agenda item.

The funding source is fund balance in the General Fund. The estimated 6/30/2022 unassigned fund balance over the policy target % is \$3,246,000 after this item.

Board Action Requested

Adopt budget amendment.

Item Presenter

David Clawson, Finance Director

DARE COUNTY

BUDGET AMENDMENT

F/Y 2021-2022

ACCOUNT	CODE			INCREASE	DECREASE
	Org	Object	Project		
Department:					
General Fund					
<u>Revenues:</u>					
Appropriated fund balance	103090	499900		\$250,000	
<u>Expenditures:</u>					
Graveyard of the Atlantic Museum	104490	560066		\$250,000	

Explanation:

Graveyard of the Atlantic Museum - addition to 2022 State budget funding.
Match to Tourism Board grant of \$250,000.

Estimated 6/30/2022 unassigned fund balance over target % after this item is \$3,246,673.

Approved by:

Board of Commissioners: _____

Date: _____

County Manager: _____

Date: _____

(sign in red)

Finance only:

Date entered: _____ Entered by: _____ Reference number: _____



*Dare County Tourism Board Request Consent
Expenditure from Long Term Unappropriated Grant Fund Line Item 4585*

Description

Expenditure of \$250,000 to Friends of the Graveyard of the Atlantic Museum for renovations, A/V and permanent exhibits. This expenditure is conditional upon the award of \$250,000 from the County.

Board Action Requested

Consent for expenditures in the amount of \$250,000 for Friends of the Graveyard of the Atlantic Museum.

Item Presenter

Diane Bognich, Director of Administration/Grants Administrator.



Consent Agenda- Placeholder

Description

1. Approval of Minutes (05/16/22)
2. Required Policies and Pertaining to Expenditure of ARP/CSLFRF
3. Amendment to Grant Project Ordinance for American Rescue Plan SLFRF
4. NC U.N.C. Greensboro Grant Application "Dare County Sheriff's Office Regional Human Trafficking Task Force"
5. NC Department of Transportation - ADA Compliant Curb Ramps
6. Avon Property Owners Association "Fourth of July" 2022 Fireworks Display

Board Action Requested

Take Appropriate Action

Item Presenter

Robert Outten, County Manager



Approval of Minutes

Description

The Board of Commissioners will review and approve their previous minutes.

Board Action Requested

Approve Previous Minutes

Item Presenter

Robert Outten, County Manager



County of Dare

P.O. Box 1000 | Manteo, NC 27954

MINUTES

DARE COUNTY BOARD OF COMMISSIONERS MEETING

Dare County Administration Building, Manteo, NC

5:00 p.m., May 16, 2022

Commissioners present: Chairman Robert Woodard, Sr., Vice Chairman Wally Overman
Rob Ross, Steve House, Jim Tobin, Danny Couch, Ervin Bateman

Commissioners absent: None

Others present: County Manager/Attorney, Robert Outten
Deputy County Manager/Finance Director, David Clawson
Master Public Information Officer, Dorothy Hester
Skyler Foley, Assistant Clerk

A full and complete account of the entire Board of Commissioners meeting is archived on a video that is available for viewing on the Dare County website www.darenc.com.

At 5:00 p.m. Chairman Woodard called to order the regularly scheduled meeting with appropriate prior public notice having been given. He invited Commissioner Danny Couch to share a prayer, and then Chairman led the Pledge of Allegiance to the flag.

ITEM 1 – OPENING REMARKS – CHAIRMAN’S UPDATE

A brief outline of the items mentioned by Chairman Woodard follows:

- Thanked fellow commissioners for joining in the Virginia S. Tillett Community Center official renaming celebration on May 12, 2022.
- He attended the 75th anniversary of the Ferry Division with Commissioners Bateman and House. He outlined how the new deluxe passenger ferry that connected Hatteras to Ocracoke would be an economic boost and provided statistics for the number of passengers and vehicles transported by the Ferry Division.
- He applauded NCDOT for how quickly they worked on N.C. 12 from the bridge to Rodanthe during the horrific wind and weather conditions experienced last week.
- As a veteran himself, he reminded everyone the weekend of May 21st was Armed Forces Appreciation Day.

ITEM 2 – PUBLIC COMMENTS

At 5:11 p.m. the County Manager explained the procedure for making public comments in Manteo and via the video link to the Fessenden Center in Buxton. No one responded to the invitation to address the Board and Public Comments closed at 5:12 p.m.

ITEM 3 – USE OF 6/30/2021 GENERAL FUND UNASSIGNED FUND BALANCE OVER TARGET PERCENTAGE

Dave Clawson explained the Unassigned Fund balance in the General Fund at June 30, 2021 was \$9,960.192 over the policy target percentage. He presented the Board with a budget amendment which recommended uses for one-time expense.

MOTION

Commissioner Ross motioned to approve the budget amendment.

Vice-Chairman Overman seconded the motion.

VOTE: AYES unanimous

ITEM 4 – USE OF GENERAL FUND SAVINGS FROM THE AMERICAN RESCUE PLAN SLFRF

Mr. Clawson provided a summary explaining the presentation of a budget amendment which reduced expenditure line items for the savings of \$7,188,564 to be transferred to a new Community Development Housing Fund to be used for the Woda Cooper Housing Project. It was further explained coupled with the \$1,811,436 from the previous item; a total of \$9 million would be available for the Woda Cooper Housing Project.

MOTION

Commissioner Tobin motioned to approve the budget amendment.

Commissioner House seconded the motion.

VOTE: AYES unanimous

ITEM 5– PUBLIC HEARING – MANAGER’S PROPOSED FY2023 BUDGET (Att. #1)

Before opening the public hearing, the County Manager explained the Frisco Fire District had sent a request for a 2% tax increase in order to construct a new fire station. Their request was received after the deadline for budget submissions had passed and after the Board had completed their budget workshop. Mr. Outten had recommended the Fire Chief ensure there was public support for the increase and should make the request to the Board next year. He had not received a response from the Fire Chief or other public comment.

Mr. Outten stated that if the Board approved the budget as presented they would not have to go back in July or August to do a CIP. They would also be approving changing the merit pay to a bonus system and changing the three paid school days to personal leave days/flex hours. Mr. Clawson stated they would be adopting the Budget Ordinance that was in the Manager’s Budget and everything on the list of corrections and changes presented to the Board.

At 5:31 p.m. the Board held a Public Hearing to receive input concerning this item. No one responded to the invitation to address the Board. The public hearing was closed at 5:31 p.m. and Mr. Outten requested the Board approve the Manager’s Budget for FY2023.

MOTION

Commissioner House motioned to approve the FY2023 Manager’s Budget

Commissioner Tobin seconded the motion.

VOTE: AYES unanimous

ITEM 6 – GRANT APPLICATION – MISS KATIE- HATTERAS INLET DREDGING

Grants and Waterways requested the Board authorize the submission of a NC DEQ Shallow Draft Navigation Fund grant application. The State would cost share 75% (\$600,000) of incurred costs for dredging Hatteras Inlet, specifically South Ferry Channel and the new Connecting Channel. See staff summary for details.

MOTION

Commissioner Couch motioned to authorize the submission of grant application and adopt resolution to sponsor the Miss Katie – Hatteras Inlet Dredging Project
Vice-Chairman Overman and Commissioner Bateman seconded the motion.

VOTE: AYES unanimous

ITEM 7 – DEQ GRANT – HATTERAS ISLAND

Barton Grover provided staff summary to explain a cultural resource survey at Hatteras Inlet was necessary to modify the current dredging permit. The county has been awarded \$30,000 in matching funds for the completion of the survey and permitting work.

MOTION

Vice-Chairman Overman motioned to approve the budget amendment and authorize the County Manager to enter into contract with Coastal Protection Engineering.

Commissioners House and Tobin seconded the motion.

VOTE: AYES unanimous

ITEM 8 – REVISED SCHEDULE OF MEETING DATES FOR REMAINDER OF 2022

At the May 25, 2022 budge workshop, the Board had discussed a change in the remaining schedule of 2022 meeting dates. The revised schedule reflected all meetings would begin at 9:00 a.m. as follows: July 18, August 1, September 6, October 3, November 7 and December 5, 2022. It was Board consensus to change the time of the July 18th meeting to 5:00 p.m.

MOTION

Vice-Chairman Overman motioned to approve the new schedule of meetings with July 18th meeting to begin at 5:00 p.m.

Commissioner Bateman seconded the motion.

VOTE: AYES unanimous

ITEM 9 – COASTAL AFFORDABLE HOUSING, LLC

Mr. Outten provided the Board with an update on the Coastal Affordable Housing project. There had been many meetings regarding the predevelopment agreement. There was ongoing communication with the state regarding the regulations and the process of procurement rules applicable to receive the federal funds set aside for affordable housing. He added the issue was not unique to Dare's project, as throughout the country the guidance for procurement and use of the federal funds was unclear at this time.

ITEM 10 – WODA COOPER COMPANIES, INC.

The Board was provided an update on the Woda Cooper project. There was concern over the cost of the parcels targeted for purchase for the Nags Head portion of the project. Mr. Outten proposed separating the Bowsertown and Nags Head projects in order to move forward with the Bowsertown location. Discussions would continue with the County and Woda over the cost of the Nags Head location for the housing project.

MOTION

Commissioner Ross motioned to separate the Woda Cooper projects and move forward with the project in Bowsertown.

Vice-Chairman Overman and Commissioner Bateman seconded the motion

VOTE: AYES unanimous

ITEM 11 – CONSENT AGENDA

The Manager announced the items as they were visually displayed in the meeting room.

MOTION

Commissioner Ross motioned to approve the Consent Agenda:

1. Approval of Minutes **(Att. #4a and 4b)**
2. Sanitation – Bulk Fuel
3. Register of Deeds – Wide Format Printer/Scanner
4. Tax Collector’s Report
5. Dominion Energy - Easement

Commissioner Tobin seconded the motion.

VOTE: AYES unanimous

ITEM 12 – BOARD APPOINTMENTS

1) Juvenile Crime Prevention Council

Commissioner House motioned to reappoint Marsha Riibner-Cady, Jennifer Alexander, Stephen Wescott, Tim White and Melinda Mogowski.

Commissioner Tobin seconded the motion.

VOTE: AYES unanimous

2) Mann’s Harbor Community Center

Commissioner Tobin motioned to reappoint Clyde Gard and Bonny Sawyer.

Vice-Chairman Overman seconded the motion.

VOTE: AYES unanimous

3) Hatteras Community Center

Commissioner Couch motioned to reappoint Laura C. Young and Rom Whitaker.

Commissioner Bateman seconded the motion.

VOTE: AYES unanimous

4) Rodanthe, Waves, Salvo Community Center Board

Commissioner Bateman motioned to reappoint Cheryl Blankenship

Commissioner Couch seconded the motion.

VOTE: AYES unanimous

5) Commission for Working Watermen

Commissioner House motioned to reappoint Amanda Hooper Walters and Joey J. Vandyke for another term.

Commissioner Tobin seconded the motion.

VOTE: AYES unanimous

- 6) Dare County Waterways Commission
Vice-Chairman Overman motioned to reappoint Danny Couch, Ernie Foster, Natalie Perry Kavanagh and Steve Coulter.
Commissioner House seconded the motion.
VOTE: AYES unanimous
- 7) Dare County Transportation Advisory Board
Commissioner House motioned to reappoint Brandi Bohanan, Chuck Lycett, Nessie Siler and Alex Chandler.
Commissioner Tobin seconded the motion.
VOTE: AYES unanimous
- 8) Fessenden Center Advisory Board
Commissioner Bateman motioned to reappoint Forrest, Paddock, Marcie Shoemaker, James Kenner and Danny Couch.
Commissioner Couch seconded the motion.
VOTE: AYES unanimous
- 9) Roanoke Island Community Center Board
Commissioner Couch motioned to reappoint Lynette Ford and Daniel Selby.
Commissioner House seconded the motion.
VOTE: AYES unanimous
- 10) Upcoming Board Appointments
The upcoming Board appointments for May, June and July, 2022 were announced.

ITEM 13 – COMMISSIONERS’ BUSINESS & MANAGER’S/ATTORNEY’S BUSINESS

A brief summary of the items mentioned by Commissioners and County Manager follows:

Commissioner Tobin

- He and Mr. Outten had gone to Rodanthe to observe the damage realized from the nor’easter which had caused significant loss of beach and at least five homes.
- Provided an update on the delivery of Miss Katie. Due to fuel tank replacement and a few other issues, she was not expected from the Gulf until August 1, 2022.
- The Board had a follow-up discussion regarding the erosion and collapse of homes.

Commissioner Ross

- He recognized “OBX Room in the Inn” for their efforts to help the homeless and less fortunate during winter months. They would be closing down during the upcoming warmer season and reopening in the fall. Over 1,700 “person nights” had been provided this year.
- The College of the Albemarle was in need of a full-time welding.
- The Virginia S. Tillett Community Center would be sending approximately thirty athletes to Raleigh to participate in the Special Olympics Games. The event would take place on June 3-5, 2022. There would be a “send-off” event at the Virginia S. Tillett Community Center on June 2, 2022 at 10:00 a.m. He wished the participants the best.

Commissioner House

- He stated the Marine Fisheries Commission would be meeting on May 25 and 26 in Beaufort. He would be attending to present two resolutions regarding striped bass.
- Discussed the shrimp amendment geared towards eliminating shrimping in local waters. He added there were also areas which prohibited trolling and control of crab spawning sanctuaries.
- He mentioned the Ferry Division's 75th anniversary event had great speeches with amazing presentations.
- For our day in history: President Andrew Johnson became the first American President to be impeached, however on May 16, 1868, the vote fell one short.
- He presented the pet of the week video with two cats named Kanga and Roo. The SPCA was seeking donations for wet food for both dogs and cats.

Vice-Chairman Overman

- Expressed he was happy to have been able to participate in the Virginia S. Tillett Community Center dedication.
- Noted the Coastal Studies Institute had recently met to discuss issues relative to a path moving forward for CSI to provide student housing on the campus and potential growth of the institution.

Commissioner Bateman

- He had provided the welcome remarks for the Outer Banks Rod and Custom Festival. It had been a great event with representation from thirty states and a few from Canada.
- He had a great time presenting medals during the Special Olympics. He was impressed with the participants' enthusiasm.
- He shared the debris was twenty miles long where the Rodanthe homes had fallen into the ocean.

Commissioner Couch

- Stated the channel was in good shape for the Hatteras Village Offshore Open. The U.S. Army Corps, the State and Dare County's Board had worked to keep the channel open. The tournament had been successful in spite of the weather issues.
- He noted Barton Grover and the engineering firm, WithersRavenel, had been handling the grant money to study resiliency and storm issues in Hatteras. He hoped some useful reports would be forthcoming as we advance our knowledge of storm water.

MANAGER'S/ATTORNEY'S BUSINESS

Mr. Outten explained the Burrus baseball facility in Hatteras had an unfinished concession stand with bathrooms. Approximately ten years ago the league playing there had begun the project with donations. It was now an unfinished and unsafe eye sore. Initially he had been told around \$20,000 would finish the structure; however, it now appeared more like \$69,000. Commissioner Couch added roughly 115 players participated in games there.

MOTION

Commissioner Bateman motioned to approve the County complete improvements to the "Burrus Field" project in Hatteras and bring it up to code using contingency funds.

Commissioner Couch seconded the motion.

VOTE: AYES unanimous

Mr. Outten explained the Consent Agenda item approved which concerned the Dominion Energy easement in front of Kitty Hawk Park needed some modifications as to location. He asked the Board to allow him to work with the Parks and Recreation Director, Tim White, Keith Sawyer from Building and Grounds and Dominion to discuss and locate the easement for the project.

MOTION

Vice-Chairman Overman motioned to approve that the County Manager, Tim White and Keith Sawyer would work with Dominion Energy for the appropriate location to bury cables for the signal easement.

Commissioner House seconded the motion.

VOTE: AYES unanimous

Mr. Outten closed with an explanation that the tennis court in Kill Devil Hills, which had been modified with wind screens for pickle ball use, was in disrepair due to a storm. The fencing had been ordered, however, supply chain issues had presented a delay in the repair.

Dorothy Hester reminded everyone that the ribbon cutting for the Dare Health and Human Services renovation would be Tuesday, May 24, 2022 at 4:00 p.m.

Mr. Clawson explained the onsite construction meeting for Avon and Buxton beach nourishment would be May 18, 2022. He advised the Board that the payment process for Hurricane Dorian's emergency measures in the amount of \$213,000 would soon begin.

At the conclusion of the meeting, Chairman Woodard asked for a motion to adjourn.

MOTION

Commissioner House motioned to adjourn the meeting.

Commissioner Bateman seconded the motion.

VOTE: AYES unanimous

At 6:35 p.m., the Board of Commissioners adjourned until 9:00 a.m., June 6, 2022.

Respectfully submitted,

By: Cheryl C. Anby
Cheryl C. Anby, Clerk to the Board



APPROVED: By: _____
Robert Woodard, Sr., Chairman
Dare County Board of Commissioners

Note: Copies of attachments (Att.), ordinances, resolutions, contracts, presentations, and supporting material considered by the Board of Commissioners at this meeting are on file in the office of the Clerk.



Required policies pertaining to expenditure of ARP/CSLFRF

Description

See attached summary.

Board Action Requested

Adopt required policies.

Item Presenter

None.

Summary of Required Policies Pertaining to Expenditure of ARP/CSLFRF

Dare County has been allocated \$7,188,564 from the Coronavirus State and Local Fiscal Recovery Funds of H.R. 1319 American Rescue Plan Act of 2021 (ARP/CSLFRF). CSLFRF are subject to the U.S. Department of Treasury (Treasury) regulations, including the Final Rule, the Award Terms and Conditions, and the Title VII implementing regulations at 31 C.F.R. Part 22. Further, ARP/CSLFRF funds are subject to the compliance requirements as listed in the Award Terms and Conditions and the Assistance Listing (21.027) which are primarily focused on the federal Uniform Grant Guidance, 2 CFR Sect. 200 (UG).

Many of the compliance measures outlined in these policies are already existing practices or an extension of existing policies of Dare County. It is a requirement of the ARP/CSLFRF that these policies be adopted /reaffirmed as it relates to the expenditure of this specific pot of funds.

- **Eligible Use Policy:** Defines the permissible and prohibited uses of the ARP/CSLFRF. It also describes the determination of use for how the County elected to expend its ARP/CSLFRF.
- **Allowable Costs and Costs Principles Policy:** Defines those items of cost that are allowable, and which are unallowable. The tests of allowability under the cost principles are: (a) the costs must be reasonable; (b) they must be allocable to eligible projects; (c) they must be given consistent treatment through application of those generally accepted accounting principles appropriate to the circumstances; and (d) they must conform to any limitations or exclusions set forth in these principles or in the ARP/CSLFRF grant award as to types or amounts of cost items.
- **Record Retention Policy:** Outlines Treasury's five-year record retention requirement for documents related to expenditures ARP/CSLFRF. This record retention requirement is longer than the traditional three-year record retention requirement. The county shall retain relevant records for a period of five years beyond the final expenditure of ARP/CSLFRF funds.
- **Nondiscrimination Policy:** Reaffirms that the unit will ensure that no person shall, on the ground of race, color, national origin (including limited English Proficiency), familial status, sex, age, or disability, be excluded from participation in, be denied the benefits of, or be otherwise, subject to discrimination under any program or activity administered by the local government, including programs/activities funded in whole or part with ARP/CSLFRF.
- **Property Management Policy:** Establishes property management standards (title, use, insurance, and disposition) for real property and equipment purchased with ARP/CLSFRRF funds. Any purchase of equipment or real property with ARP/SLFRF funds must be consistent with the Uniform Guidance at 2 CFR Part 200, Subpart D. Consistent with 2 CFR 200.311 and 2 CFR 200.313, any equipment or real property acquired using SLFRF funds shall vest in the non-Federal entity. Any acquisition and maintenance of equipment or real property must also be in compliance with relevant laws and regulations.

**ELIGIBLE USE POLICY FOR THE EXPENDITURE OF AMERICAN RESCUE PLAN ACT OF 2021
CORONAVIRUS STATE AND LOCAL FISCAL RECOVERY FUNDS BY THE COUNTY OF DARE, NC**

WHEREAS the County of Dare, NC has received an allocation of funds from the Coronavirus State and Local Fiscal Recovery Funds of H.R. 1319 American Rescue Plan Act of 2021 (ARP/CSLFRF); and

WHEREAS US Treasury is responsible for implementing ARP/CSLFRF and has enacted a Final Rule outlining eligible projects; and

WHEREAS the funds may be used for projects within these categories, to the extent authorized by state law.

1. Support COVID-19 public health expenditures, by funding COVID-19 mitigation and prevention efforts, medical expenses, behavioral healthcare, preventing and responding to violence, and certain public health and safety staff;
2. Address negative economic impacts caused by the public health emergency, including economic harms to households, small businesses, non-profits, impacted industries, and the public sector;
3. Replace lost public sector revenue, using this funding to provide government services to the extent of the reduction in revenue experienced due to the pandemic;
4. Provide premium pay for essential workers, offering additional support to those who have borne and will bear the greatest health risks because of their service in critical infrastructure sectors; and,
5. Invest in water, sewer, and broadband infrastructure, making necessary investments to improve access to clean drinking water, support vital wastewater and stormwater infrastructure, and to expand access to broadband internet; and

WHEREAS ARP/CSLFRF are subject to the provisions of the federal Uniform Grant Guidance, 2 CFR Part 200 (UG), as provided in the Assistance Listing; and

WHEREAS US Treasury has issued a Compliance and Reporting Guidance v.2.1 (November 15, 2021) dictating implementation of the ARP/CSLFRF award terms and compliance requirements; and

WHEREAS the Compliance and Reporting Guidance states on page 6 that

Per 2 CFR Part 200.303, your organization must develop and implement effective internal controls to ensure that funding decisions under the SLFRF award constitute eligible uses of funds, and document determinations.

BE IT RESOLVED that the governing board of the County of Dare, NC hereby adopts and enacts the following Eligible Use Policy for the expenditure of ARP/CSLFRF.

Adopted this 6th day of June, 2022.

Chairman, Board of County Commissioners

[SEAL]
COUNTY OF DARE, NORTH CAROLINA

Clerk to the Board

County of Dare, NC
Eligible Use Policy for American Rescue Plan Act of 2021 Coronavirus State and Local Fiscal
Recovery Funds

This policy defines the permissible and prohibited uses of the Coronavirus State and Local Fiscal Recovery Funds of H.R. 1319 American Rescue Plan Act of 2021 (ARP/CSLFRF). It also describes the determination of use for how the County of Dare, NC (County) elected to expend its ARP/CSLFRF.

I. PERMISSIBLE USES OF ARP/CSLFRF

US Treasury issued its Final Rule regarding use of ARPA funds on January 6, 2022, to be effective as of April 1, 2022. The Final Rule identifies permissible uses of ARP/CSLFRF and certain limitations and process requirements. Local governments must allocate ARP/CSLFRF no later than December 31, 2024 and disburse all funding no later than December 31, 2026. Failure of an entity to expend all funds by December 31, 2026 will result in forfeiture of ARPA funds.

ARP/CSLFRF may be used for projects within the following categories of expenditures:

1. Support COVID-19 public health expenditures, by funding COVID-19 mitigation and prevention efforts, medical expenses, behavioral healthcare, preventing and responding to violence, and certain public health and safety staff;
2. Address negative economic impacts caused by the public health emergency, including economic harms to workers, households, small businesses, non-profits, impacted industries, and the public sector;
3. Replace lost public sector revenue, using this funding to provide government services to the extent of the reduction in revenue experienced due to the pandemic;
4. Provide premium pay for essential workers, offering additional support to those who have borne and will bear the greatest health risks because of their service in critical infrastructure sectors; and
5. Invest in water, sewer, and broadband infrastructure, making necessary investments to improve access to clean drinking water, support vital wastewater and stormwater infrastructure, and to expand access to broadband internet; and

II. PROHIBITED USES OF ARPA FUNDING

ARP/CSLFRF and the US Treasury's Final Rule prohibit certain uses of ARP/CSLFRF. Specifically, ARP/CSLFRF may not be used for projects within the following categories of expenditures:

1. To make a deposit into a pension fund that constitutes an extraordinary payment of an accrued, unfunded liability (note that routine contributions as part of a payroll obligation for an eligible project are allowed.);
2. To borrow money or make debt service payments;
3. To replenish rainy day funds or fund other financial reserves;

4. To satisfy an obligation arising from a settlement agreement, judgment, consent decree, or judicially confirmed debt restricting in a judicial, administrative, or regulatory proceeding (There is an exception to this prohibition if the settlement or judgment requires the County to provide services to respond to the COVID-19 public health emergency or its negative economic impacts or to provide government services, then the costs of those otherwise ARP/CSLFRF-eligible projects are allowed.);
5. For a project that includes a term or condition that undermines efforts to stop the spread of COVID-19 or discourages compliance with recommendations and guidelines in CDC guidance for stopping the spread of COVID-19;
6. In violation of the conflict-of-interest requirements imposed by the award terms and 2 CFR 200.318(c).
7. For any expenditure that would violate other applicable federal, state, and local laws and regulations.

The County, and any of its contractors or subrecipients, may not expend any ARP/CSLFRF for these purposes.

III. DETERMINATION OF USE

By adoption of a grant project ordinance on February 22, 2022, the Dare County Board of Commissioners elected to take the standard allowance, as authorized by 31 CFR Part 35.6(d)(1) and expend all its ARP/CSLFRF for the provision of government services. ARP/CSLFRF were appropriated and authorized for expenditure for the following project.

1. Project Name: Public Safety Salaries & Fringes
 - a. Description: Public Safety salaries & fringes from 7/1/2021 through 2/28/2022, specifically for Sheriff, Detention Center, Communications, and Emergency Management.
 - b. Project Expenditure Category: 6-Revenue Replacement.
 - c. Project Expenditure Subcategory: 6.1-Provision of Government Services.
 - d. Project Budget: \$7,204,564.
 - e. Cost Items:
 - i. Compensation-personal services \$4,893,104
 - ii. Compensation-fringe benefits \$2,311,460
 - f. Project timeline: Expenditure of funds July 1, 2021 through February 28, 2022; report all eligible expenditures as of March 31, 2022; close out grant as of June 30, 2022.
2. The Finance Director must collect and document required information for purposes of completing the required Project and Expenditure reports and to satisfy the requirements of the grantor agency and the grant agreements, including payroll documentation in accordance with 2 CFR 200.430 & 2 CFR 200.431 and the County's Allowable Costs and Cost Principles Policy.
3. The Finance Director must maintain all supporting documentation and financial information at least until December 31, 2031.

IV. POLICY AUTHORITY

Following initial adoption of this policy by the governing board, the Finance Director is hereby authorized to administer, enforce, and make revisions to this policy.

ALLOWABLE COSTS AND COST PRINCIPLES POLICY FOR THE EXPENDITURE OF AMERICAN RESCUE PLAN ACT OF 2021 CORONAVIRUS STATE AND LOCAL FISCAL RECOVERY FUNDS BY THE COUNTY OF DARE, NC

WHEREAS the County of Dare, NC has received an allocation of funds from the Coronavirus State and Local Fiscal Recovery Funds of H.R. 1319 American Rescue Plan Act of 2021 (ARP/CSLFRF); and

WHEREAS the funds may be used for projects within these categories, to the extent authorized by state law.

1. Support COVID-19 public health expenditures, by funding COVID-19 mitigation and prevention efforts, medical expenses, behavioral healthcare, preventing and responding to violence, and certain public health and safety staff;
2. Address negative economic impacts caused by the public health emergency, including economic harms to households, small businesses, non-profits, impacted industries, and the public sector;
3. Replace lost public sector revenue, using this funding to provide government services to the extent of the reduction in revenue experienced due to the pandemic;
4. Provide premium pay for essential workers, offering additional support to those who have borne and will bear the greatest health risks because of their service in critical infrastructure sectors; and,
5. Invest in water, sewer, and broadband infrastructure, making necessary investments to improve access to clean drinking water, support vital wastewater and stormwater infrastructure, and to expand access to broadband internet.

WHEREAS ARP/CSLFRF are subject to the provisions of the federal Uniform Grant Guidance, 2 CFR Sect. 200 (UG), as provided in the Assistance Listing; and

WHEREAS the Compliance and Reporting Guidance for the State and Local Fiscal Recovery Funds provides, in relevant part:

Allowable Costs/Cost Principles. As outlined in the Uniform Guidance at 2 CFR Part 200, Subpart E regarding Cost Principles, allowable costs are based on the premise that a recipient is responsible for the effective administration of Federal awards, application of sound management practices, and administration of Federal funds in a manner consistent with the program objectives and terms and conditions of the award. Recipients must implement robust internal controls and effective monitoring to ensure compliance with the Cost Principles, which are important for building trust and accountability.

ARP/CSLFRF may be, but are not required to be, used along with other funding sources for a given project. Note that ARP/CSLFRF may not be used for a non-Federal cost share or match where prohibited by other Federal programs, e.g., funds may not be used for the State share for Medicaid.

Treasury's Interim Final Rule and guidance and the Uniform Guidance outline the types of costs that are allowable, including certain audit costs. For example, per 2 CFR 200.425, a reasonably proportionate share of the costs of audits required by the Single Audit Act Amendments of 1996 are allowable; however, costs for audits that were not performed in accordance with 2 CFR Part 200, Subpart F are not allowable. Please see 2 CFR Part 200, Subpart E regarding the Cost Principles for more information.

- a. Administrative costs: Recipients may use funds for administering the SLFRF program, including costs of consultants to support effective management and oversight, including consultation for ensuring compliance with legal, regulatory, and other requirements. Further, costs must be reasonable and allocable as outlined in 2 CFR 200.404 and 2 CFR 200.405. Pursuant to the ARP/CSLFRF Award Terms and Conditions, recipients are permitted to charge both direct and indirect costs to their SLFRF award as administrative costs. Direct costs are those that are identified specifically as costs of implementing the ARP/CSLFRF program objectives, such as contract support, materials, and supplies for a project. Indirect costs are general overhead costs of an organization where a portion of such costs are allocable to the ARP/CSLFRF award such as the cost of facilities or administrative functions like a director's office. Each category of cost should be treated consistently in like circumstances as direct or indirect, and recipients may not charge the same administrative costs to both direct and indirect cost categories, or to other programs. If a recipient has a current Negotiated Indirect Costs Rate Agreement (NICRA) established with a Federal cognizant agency responsible for reviewing, negotiating, and approving cost allocation plans or indirect cost proposals, then the recipient may use its current NICRA. Alternatively, if the recipient does not have a NICRA, the recipient may elect to use the de minimis rate of 10 percent of the modified total direct costs pursuant to 2 CFR 200.414(f).
- b. Salaries and Expenses: In general, certain employees' wages, salaries, and covered benefits are an eligible use of ARP/CSLFRF; and

WHEREAS Subpart E of the UG dictates allowable costs and cost principles for expenditure of ARP/CSLFRF; and

WHEREAS Subpart E of the UG (specifically, 200.400) states that:

The application of these cost principles is based on the fundamental premises that:

- (a) The non-Federal entity is responsible for the efficient and effective administration of the Federal award through the application of sound management practices.
- (b) The non-Federal entity assumes responsibility for administering Federal funds in a manner consistent with underlying agreements, program objectives, and the terms and conditions of the Federal award.
- (c) The non-Federal entity, in recognition of its own unique combination of staff, facilities, and experience, has the primary responsibility for

employing whatever form of sound organization and management techniques may be necessary in order to assure proper and efficient administration of the Federal award.

- (d) The application of these cost principles should require no significant changes in the internal accounting policies and practices of the non-Federal entity. However, the accounting practices of the non-Federal entity must be consistent with these cost principles and support the accumulation of costs as required by the principles, and must provide for adequate documentation to support costs charged to the Federal award.
- (e) In reviewing, negotiating and approving cost allocation plans or indirect cost proposals, the cognizant agency for indirect costs should generally assure that the non-Federal entity is applying these cost accounting principles on a consistent basis during their review and negotiation of indirect cost proposals. Where wide variations exist in the treatment of a given cost item by the non-Federal entity, the reasonableness and equity of such treatments should be fully considered.
- (f) For non-Federal entities that educate and engage students in research, the dual role of students as both trainees and employees (including pre- and post-doctoral staff) contributing to the completion of Federal awards for research must be recognized in the application of these principles.
- (g) The non-Federal entity may not earn or keep any profit resulting from Federal financial assistance, unless explicitly authorized by the terms and conditions of the Federal award;

BE IT RESOLVED that the governing board of the County of Dare, NC hereby adopts and enacts the following Allowable Costs and Cost Principles Policy for the expenditure of ARP/CSLFRF.

Adopted this 6th day of June, 2022.

Chairman, Board of County Commissioners

[SEAL]
COUNTY OF DARE, NORTH CAROLINA

Clerk to the Board

County of Dare, NC
Allowable Costs and Costs Principles Policy for American Rescue Plan Act of 2021 Coronavirus
State and Local Fiscal Recovery Funds

I. ALLOWABLE COSTS AND COSTS PRINCIPLES POLICY OVERVIEW

Title 2 U.S. Code of Federal Regulations Part 200, Uniform Administrative Requirements, Cost Principles, and Audit Requirements for Federal Awards, commonly called Uniform Guidance (UG), specifically Subpart E, defines those items of cost that are allowable, and which are unallowable. The tests of allowability under these principles are: (a) the costs must be reasonable; (b) they must be allocable to eligible projects under the Coronavirus State and Local Fiscal Recovery Funds of H.R. 1319 American Rescue Plan Act of 2021 (ARP/CSLFRF); (c) they must be given consistent treatment through application of those generally accepted accounting principles appropriate to the circumstances; and (d) they must conform to any limitations or exclusions set forth in these principles or in the ARP/CSLFRF grant award as to types or amounts of cost items. Unallowable items fall into two categories: expenses which are by their nature unallowable (e.g., alcohol), and unallowable activities (e.g., fund raising).

The County of Dare, NC (County) shall adhere to all applicable cost principles governing the use of federal grants. This policy addresses the proper classification of both direct and indirect charges to ARP/CSLFRF funded projects and enacts procedures to ensure that proposed and actual expenditures are consistent with the ARP/CSLFRF grant award terms and all applicable federal regulations in the UG.

Responsibility for following these guidelines lies with the Finance department, who is charged with the administration and financial oversight of the ARP/CSLFRF. Further, all local government employees and officials who are involved in obligating, administering, expending, or monitoring ARP/CSLFRF grant funded projects should be well versed with the categories of costs that are generally allowable and unallowable. Questions on the allowability of costs should be directed to the Finance department. As questions on allowability of certain costs may require interpretation and judgment, local government personnel are encouraged to ask for assistance in making those determinations.

Failure to adequately follow this policy and related procedures could result in questioned costs, audit findings, potential repayment of disallowed costs and discontinuance of funding.

II. GENERAL COST ALLOWABILITY CRITERIA

All costs expended using ARP/CSLFRF must meet the following general criteria:

1. Be necessary and reasonable for the proper and efficient performance and administration of the grant program.

A cost must be *necessary* to achieve a project object. When determining whether a cost is necessary, consideration may be given to:

- o Whether the cost is needed for the proper and efficient performance of the grant project.
- o Whether the cost is identified in the approved project budget or application.

- Whether the cost aligns with identified needs based on results and findings from a needs assessment.
- Whether the cost addresses project goals and objectives and is based on program data.

A cost is *reasonable* if, in its nature and amount, it does not exceed that which would be incurred by a prudent person under the circumstances prevailing at the time the decision to incur the cost was made. For example, reasonable means that sound business practices were followed, and purchases were comparable to market prices. When determining reasonableness of a cost, consideration must be given to:

- Whether the cost is a type generally recognized as ordinary and necessary for the operation of the County or the proper and efficient performance of the federal award.
- The restraints or requirements imposed by factors, such as: sound business practices; arm’s-length bargaining; federal, state, and other laws and regulations; and terms and conditions of the ARP/CSLFRF award.
- Market prices for comparable goods or services for the geographic area.
- Whether individuals concerned acted with prudence in the circumstances considering their responsibilities to the County, its employees, the public at large, and the federal government.
- Whether the County significantly deviates from its established practices and policies regarding the incurrence of costs, which may unjustifiably increase the ARP/CSLFRF award’s cost.

2. **Be allocable to the ARP/CSLFRF federal award.** A cost is allocable to the ARP/CSLFRF award if the goods or services involved are chargeable or assignable to the ARP/CSLFRF award in accordance with the relative benefit received. This means that the ARP/CSLFRF grant program derived a benefit in proportion to the funds charged to the program.

If a cost benefits two or more projects or activities in proportions that can be determined without undue effort or cost, the cost must be allocated to the projects based on the proportional benefit. If a cost benefits two or more projects or activities in proportions that cannot be determined because of the interrelationship of the work involved, then the costs may be allocated or transferred to benefitted projects on any reasonable documented basis. Where the purchase of equipment or other capital asset is specifically authorized by the ARP/CSLFRF, the costs are assignable to the Federal award regardless of the use that may be made of the equipment or other capital asset involved when no longer needed for the purpose for which it was originally required.

3. **Be authorized and not prohibited under state or local laws or regulations.**
4. **Conform to any limitations or exclusions set forth in the principles, federal laws, ARP/CSLFRF award terms, and other governing regulations as to types or amounts of cost items.**
5. **Be consistent with policies, regulations, and procedures that apply uniformly to both the ARP/CSLFRF federal award and other activities of the County.**

6. **Be accorded consistent treatment.** A cost MAY NOT be assigned to a federal award as a direct cost and also be charged to a federal award as an indirect cost. And a cost must be treated consistently for both federal award and non-federal award expenditures.
7. **Be determined in accordance with generally accepted accounting principles (GAAP), unless provided otherwise in the UGG.**
8. **Be net of all applicable credits.** The term “applicable credits” refers to those receipts or reduction of expenditures that operate to offset or reduce expense items allocable to the federal award. Typical examples of such transactions are purchase discounts; rebates or allowances; recoveries or indemnities on losses; and adjustments of overpayments or erroneous charges. To the extent that such credits accruing to and received by the local government related to the federal award, they shall be credited to the ARP/CSLFRF award, either as a cost reduction or a cash refund, as appropriate and consistent with the award terms.
9. **Be adequately documented.**

III. SELECTED ITEMS OF COST

The UGG examines the allowability of fifty-five (55) specific cost items (commonly referred to as Selected Items of Cost) at 2 CFR § 200.420-.475.

Finance department personnel responsible for determining cost allowability must be familiar with the Selected Items of Cost. The County must follow the applicable regulations when charging these specific expenditures to the ARP/CSLFRF grant. Finance department personnel will check costs against the selected items of cost requirements to ensure the cost is allowable and that all process and documentation requirements are followed. In addition, State laws, the County regulations, and program-specific rules may deem a cost as unallowable, and Finance department personnel must follow those non-federal rules as well.

Exhibit A identifies and summarizes the Selected Items of Cost.

IV. DIRECT AND INDIRECT COSTS

Allowable and allocable costs must be appropriately classified as direct or indirect charges. It is essential that each item of cost be treated consistently in like circumstances either as a direct or an indirect cost.

Direct costs are expenses that are specifically associated with a particular ARP/CSLFRF-eligible project and that can be directly assigned to such activities relatively easily with a high degree of accuracy. Common examples of direct costs include salary and fringe benefits of personnel directly involved in undertaking an eligible project, equipment and supplies for the project, subcontracted service provider, or other materials consumed or expended in the performance of a grant-eligible project.

Indirect costs are (1) costs incurred for a common or joint purpose benefitting more than one ARP/CSLFRF-eligible project, and (2) not readily assignable to the project specifically benefited, without effort disproportionate to the results achieved. They are expenses that benefit more

than one project or even more than one federal grant. Common examples of indirect costs include utilities, local telephone charges, shared office supplies, administrative or secretarial salaries.

For indirect costs, the County may charge a 10 percent de minimis rate of modified total direct costs (MTDC). According to UGG Section 200.68 MTDC means all direct salaries and wages, applicable fringe benefits, materials and supplies, services, travel, and up to the first \$25,000 of each subaward (regardless of the period of performance the subawards under the award). MTDC EXCLUDES equipment, capital expenditures, charges for patient care, rental costs, tuition remission, scholarships and fellowships, participant support costs and the portion of each subaward in excess of \$25,000.

V. SPECIAL PROVISIONS FOR STATE AND LOCAL GOVERNMENTS

There are some special provisions of the UG that apply only to states, local governments, and Indian Tribes.

§ 200.444 General costs of government.

(a) For states, local governments, and Indian Tribes, the general costs of government are unallowable (except as provided in § 200.475). Unallowable costs include:

- (1) Salaries and expenses of the Office of the Governor of a state or the chief executive of a local government or the chief executive of an Indian tribe;
- (2) Salaries and other expenses of a state legislature, tribal council, or similar local governmental body, such as a county supervisor, city council, school board, etc., whether incurred for purposes of legislation or executive direction;
- (3) Costs of the judicial branch of a government;
- (4) Costs of prosecutorial activities unless treated as a direct cost to a specific program if authorized by statute or regulation (however, this does not preclude the allowability of other legal activities of the Attorney General as described in § 200.435); and
- (5) Costs of other general types of government services normally provided to the general public, such as fire and police, unless provided for as a direct cost under a program statute or regulation. (Note that expenditures of ARP/CSLFRF in the revenue replacement category are explicitly authorized in the Final Rule to be spent on general government services.)

(b) For Indian tribes and Councils of Governments (COGs) (see definition for *Local government* in § 200.1 of this part), up to 50% of salaries and expenses directly attributable to managing and operating Federal programs by the chief executive and his or her staff can be included in the indirect cost calculation without documentation.

§ 200.416 COST ALLOCATION PLANS AND INDIRECT COST PROPOSALS.

(a) For states, local governments and Indian tribes, certain services, such as motor pools, computer centers, purchasing, accounting, etc., are provided to operating agencies on a centralized basis. Since Federal awards are performed within the individual operating agencies, there needs to be a process whereby these central service costs can be identified and assigned to benefitted activities on a reasonable and consistent basis. The central service cost allocation plan provides that process.

(b) Individual operating agencies (governmental department or agency), normally charge Federal awards for indirect costs through an indirect cost rate. A separate indirect cost rate(s) proposal for each operating agency is usually necessary to claim indirect costs under Federal awards. Indirect costs include:

- (1) The indirect costs originating in each department or agency of the governmental unit carrying out Federal awards and
- (2) The costs of central governmental services distributed through the central service cost allocation plan and not otherwise treated as direct costs.

(c) The requirements for development and submission of cost allocation plans (for central service costs and public assistance programs) and indirect cost rate proposals are contained in appendices V, VI and VII to this part.

§ 200.417 INTERAGENCY SERVICE.

The cost of services provided by one agency to another within the governmental unit may include allowable direct costs of the service plus a pro-rated share of indirect costs. A standard indirect cost allowance equal to ten percent of the direct salary and wage cost of providing the service (excluding overtime, shift premiums, and fringe benefits) may be used in lieu of determining the actual indirect costs of the service. These services do not include centralized services included in central service cost allocation plans as described in Appendix V to Part 200.

VI. COST ALLOWABILITY DETERMINATION PROCESS

PREAPPROVAL COST ALLOWABILITY REVIEW

Before the ARP/CSLFRF-funded project was authorized, the Finance Director determined that the public safety compensation-personal services and compensation-fringe benefits cost items were allowable and allocable, and would be charged as direct expenses to the ARP/CSLFRF federal award.

POST-EXPENDITURE COST ALLOWABILITY REVIEW

The identified cost items proceeded through the County's normal disbursement process. The Finance department must retain appropriate documentation of budgeted cost items and actual obligations and expenditures of cost items for the authorized project.

VII. COST TRANSFERS

Any costs charged to the ARP/CSLFRF federal award that do not meet the allowable cost criteria must be removed from the award account and charged to an account that does not require adherence to federal UGG or other applicable guidelines.

VIII. POLICY AUTHORITY

Following initial adoption of this policy by the governing board, the Finance Director is hereby authorized to administer, enforce, and make revisions to this policy.

EXHIBIT A

Selected Items of Cost	Uniform Guidance General Reference	Allowability
Advertising and public relations costs	2 CFR § 200.421	Allowable with restrictions
Advisory councils	2 CFR § 200.422	Allowable with restrictions
Alcoholic beverages	2 CFR § 200.423	Unallowable
Alumni/ae activities	2 CFR § 200.424	Not specifically addressed
Audit services	2 CFR § 200.425	Allowable with restrictions
Bad debts	2 CFR § 200.426	Unallowable
Bonding costs	2 CFR § 200.427	Allowable with restrictions
Collection of improper payments	2 CFR § 200.428	Allowable
Commencement and convocation costs	2 CFR § 200.429	Not specifically addressed
Compensation – personal services	2 CFR § 200.430	Allowable with restrictions; Special conditions apply (e.g., § 200.430(i)(5))
Compensation – fringe benefits	2 CFR § 200.431	Allowable with restrictions
Conferences	2 CFR § 200.432	Allowable with restrictions
Contingency provisions	2 CFR § 200.433	Unallowable with exceptions
Contributions and donations	2 CFR § 200.434	Unallowable (made by non-federal entity); not reimbursable but value may be used as cost sharing or matching (made to non-federal entity)

Defense and prosecution of criminal and civil proceedings, claims, appeals and patent infringements	2 CFR § 200.435	Allowable with restrictions
Depreciation	2 CFR § 200.436	Allowable with qualifications
Employee health and welfare costs	2 CFR § 200.437	Allowable with restrictions
Entertainment costs	2 CFR § 200.438	Unallowable with exceptions
Equipment and other capital expenditures	2 CFR § 200.439	Allowability based on specific requirement
Exchange rates	2 CFR § 200.440	Allowable with restrictions
Fines, penalties, damages and other settlements	2 CFR § 200.441	Unallowable with exceptions
Fund raising and investment management costs	2 CFR § 200.442	Unallowable with exceptions
Gains and losses on disposition of depreciable assets	2 CFR § 200.443	Allowable with restrictions
General costs of government	2 CFR § 200.444	Unallowable with exceptions
Goods and services for personal use	2 CFR § 200.445	Unallowable (goods/services); allowable (housing) with restrictions
Idle facilities and idle capacity	2 CFR § 200.446	Idle facilities - unallowable with exceptions; Idle capacity - allowable with restrictions
Insurance and indemnification	2 CFR § 200.447	Allowable with restrictions
Intellectual property	2 CFR § 200.448	Allowable with restrictions
Interest	2 CFR § 200.449	Allowable with restrictions
Lobbying	2 CFR § 200.450	Unallowable

Losses on other awards or contracts	2 CFR § 200.451	Unallowable (however, they are required to be included in the indirect cost rate base for allocation of indirect costs)
Maintenance and repair costs	2 CFR § 200.452	Allowable with restrictions
Materials and supplies costs, including costs of computing devices	2 CFR § 200.453	Allowable with restrictions
Memberships, subscriptions, and professional activity costs	2 CFR § 200.454	Allowable with restrictions; unallowable for lobbying organizations
Organization costs	2 CFR § 200.455	Unallowable except federal prior approval
Participant support costs	2 CFR § 200.456	Allowable with prior approval of the federal awarding agency
Plant and security costs	2 CFR § 200.457	Allowable; capital expenditures are subject to § 200.439
Pre-award costs	2 CFR § 200.458	Allowable if consistent with other allowabilities and with prior approval of the federal awarding agency
Professional services costs	2 CFR § 200.459	Allowable with restrictions
Proposal costs	2 CFR § 200.460	Allowable with restrictions
Publication and printing costs	2 CFR § 200.461	Allowable with restrictions
Rearrangement and reconversion costs	2 CFR § 200.462	Allowable (ordinary and normal)
Recruiting costs	2 CFR § 200.463	Allowable with restrictions
Relocation costs of employees	2 CFR § 200.464	Allowable with restrictions
Rental costs of real property and equipment	2 CFR § 200.465	Allowable with restrictions
Scholarships and student aid costs	2 CFR § 200.466	Not specifically addressed

Selling and marketing costs	2 CFR § 200.467	Unallowable with exceptions
Specialized service facilities	2 CFR § 200.468	Allowable with restrictions
Student activity costs	2 CFR § 200.469	Unallowable unless specifically provided for in the federal award
Taxes (including Value Added Tax)	2 CFR § 200.470	Allowable with restrictions
Termination costs	2 CFR § 200.471	Allowable with restrictions
Training and education costs	2 CFR § 200.472	Allowable for employee development
Transportation costs	2 CFR § 200.473	Allowable with restrictions
Travel costs	2 CFR § 200.474	Allowable with restrictions
Trustees	2 CFR § 200.475	Not specifically addressed

County of Dare, NC
Record Retention Policy for Documents Created or Maintained Pursuant to the ARP/CSLFRF
Award

Retention of Records: The Coronavirus Local Fiscal Recovery Funds (CSLFRF) Award Terms and Conditions and the Compliance and Reporting Guidance set forth the U.S. Department of Treasury's (Treasury) record retention requirements for the ARP/CSLFRF award.

It is the policy of the County of Dare, NC (County) to follow Treasury's record retention requirements as it expends CSLFRF pursuant to the APR/CSLFRF award. Accordingly, the County agrees to the following:

- Retain all financial and programmatic records related to the use and expenditure of CSLFRF pursuant to the ARP/CSLFRF award for a period of five (5) years after all CLFRF funds have been expended or returned to Treasury, whichever is later.
- Retain records for real property and equipment acquired with CSLFRF for five years after final disposition.
- Ensure that the financial and programmatic records retained sufficiently evidence compliance with section 603(c) of the Social Security Act "ARPA," Treasury's regulations implementing that section, and guidance issued by Treasury regarding the foregoing.
- Allow the Treasury Office of Inspector General and the Government Accountability Office, or their authorized representatives, the right of timely and unrestricted access to any records for the purpose of audits or other investigations.
- If any litigation, claim, or audit is started before the expiration of the 5-year period, the records will be retained until all litigation, claims, or audit findings involving the records have been resolved.

Covered Records: For purposes of this policy, records are information, regardless of physical form or characteristics, that are created, received, or retained that evidence the County's expenditure of CSLFRF funds on eligible projects, programs, or activities pursuant to the ARP/CSLFRF award. Records that shall be retained pursuant to this policy include, but are not limited to, the following:

- Financial statements and accounting records evidencing expenditures of CSLFRF for eligible projects, programs, or activities.
- Documentation of rational to support a particular expenditure of CSLFRF (e.g., expenditure constitutes a general government service);
- Documentation of administrative costs charged to the ARP/CSLFRF award;
- Procurement documents evidencing the significant history of a procurement, including, at a minimum, the rationale for the method of procurement, selection of contract type, contractor selection or rejection, and the basis for contract cost or price;
- Subaward agreements and documentation of subrecipient monitoring;
- Documentation evidencing compliance with the Uniform Guidance property management standards set forth in 2 C.F.R. §§ 200.310-316 and 200.329;
- Personnel and payroll records for full-time and part-time employees compensated with CSLFRF, including time and effort reports; and
- Indirect cost rate proposals

Storage: County's records must be stored in a safe, secure, and accessible manner. Wherever practicable, such records should be collected, transmitted, and stored in open and machine-readable formats.

Departmental Responsibilities: Any department or unit of the County, and its employees, who are responsible for creating or maintaining the covered documents in this policy shall comply with the terms of this policy. Failure to do so may subject the County to civil and/or criminal liability. Any employee who fails to comply with the record retention requirements set forth herein may be subject to disciplinary sanctions, including suspension or termination. Any questions about this policy should be directed to the Finance department.

The Finance department is responsible for identifying the documents that County must or should retain and arrange for the proper storage and retrieval of records. Finance department staff shall also ensure that all personnel subject to the terms of this policy are aware of the record retention requirements set forth herein.

Reporting Policy Violations: The County is committed to enforcing this policy as it applies to all forms of records. Any employee that suspects the terms of this policy have been violated shall report the incident immediately to that employee's supervisor. If an employee is not comfortable bringing the matter up with the supervisor, the employee may bring the matter to the attention of the County Manager. The County prohibits, any form of discipline, reprisal, intimidation, or retaliation for reporting incidents of inappropriate conduct of any kind, pursuing any record destruction claim, or cooperating in related investigations.

Policy Authority: Following initial adoption of this policy by the governing board, the Finance Director is hereby authorized to administer, enforce, and make revisions to this policy.

Adopted this 6th day of June, 2022.

Chairman, Board of County Commissioners

[SEAL]
COUNTY OF DARE, NORTH CAROLINA

Clerk to the Board

NONDISCRIMINATION POLICY FOR THE EXPENDITURE OF AMERICAN RESCUE PLAN ACT OF 2021 CORONAVIRUS STATE AND LOCAL FISCAL RECOVERY FUNDS BY THE COUNTY OF DARE, NC

WHEREAS, the County of Dare, NC has received an allocation of funds from the Coronavirus State and Local Fiscal Recovery Funds of H.R. 1319 American Rescue Plan Act of 2021 (ARP/CSLFRF); and

WHEREAS, ARP/CSLFRF are subject to the U.S. Department of Treasury (Treasury) regulations, including the Final Rule, the Award Terms and Conditions, and the Title VII implementing regulations at 31 C.F.R. Part 22; and

WHEREAS, pursuant to the ARP/CSLFRF Award Terms and Conditions, and as a condition of receiving ARP/CSLFRF, the County agrees to follow all federal statutes and regulations prohibiting discrimination in its administration of ARP/CSLFRF under the terms and conditions of the ARP/CSLFRF award, including, without limitation, the following:

- i. Title VI of the Civil Rights Act of 1964 (42 U.S.C. §§ 2000d et seq.) and Treasury's implementing regulations at 31 C.F.R. Part 22, which prohibit discrimination on the basis of race, color, or national origin within programs or activities receiving federal financial assistance;
- ii. The Fair Housing Act, Title VIII of the Civil Rights Act of 1968 (42 U.S.C. §§ 3601 et seq.), which prohibits discrimination in housing on the basis of race, color, religion, national origin, sex, familial status, or disability;
- iii. Section 504 of the Rehabilitation Act of 1973, as amended (29 U.S.C. § 794), which prohibits discrimination on the basis of disability under any program or activity receiving Federal financial assistance;
- iv. The Age Discrimination Act of 1975, as amended (42 U.S.C. §§ 6101 et seq.), and Treasury's implementing regulations at 31 C.F.R. Part 23, which prohibit discrimination on the basis of age in programs or activities receiving federal financial assistance; and
- v. Title II of the Americans with Disabilities Act of 1990, as amended (42 U.S.C. §§ 12101 et seq.), which prohibits discrimination on the basis of disability under programs, activities, and services provided or made available by state and local governments or instrumentalities or agencies thereto.

BE IT RESOLVED that the governing board of the County of Dare, NC hereby adopts and enacts the following Nondiscrimination Policy, which shall apply to the operations of any program, activity, or facility that is supported in whole, or in part, by expenditures CSLFRF pursuant to the ARP/CSLFRF award.

Adopted this 6th day of June, 2022.

Chairman, Board of County Commissioners

[SEAL]
COUNTY OF DARE, NORTH CAROLINA

Clerk to the Board

County of Dare, NC
Nondiscrimination Policy for American Rescue Plan Act of 2021 Coronavirus State and Local
Fiscal Recovery Funds

It is the policy of the County of Dare, NC (County) to ensure that no person shall, on the ground of race, color, national origin (including limited English Proficiency), familial status, sex, age, or disability, be excluded from participation in, be denied the benefits of, or be otherwise subject to discrimination under any program or activity administered by the County, including programs or activities that are funded in whole or part, with Coronavirus State and Local Fiscal Recovery Funds (CSLFRF), which the County received from the U.S. Department of Treasury (Treasury) pursuant to Sections 602 and 603 of the Social Security Act, as added by Section 9901 of the American Rescue Plan Act of 2021, Pub. L. No. 117-2 (herein the “ARP/CSLFRF award”).

I. Governing Statutory & Regulatory Authorities

As required by the CSLFRF Award Terms and Conditions, the County shall ensure that each “activity,” “facility,” or “program”¹ that is funded in whole, or in part, with CSLFRF and administered under the ARP/CSLFRF award, will be facilitated, operated, or conducted in compliance with the following federal statutes and federal regulations prohibiting discrimination. These include, but are not limited to, the following:

- i. Title VI of the Civil Rights Act of 1964 (42 U.S.C. §§ 2000d et seq.) and Treasury’s implementing regulations at 31 C.F.R. Part 22, which prohibit discrimination on the basis of race, color, or national origin under programs or activities receiving federal financial assistance;
- ii. The Fair Housing Act, Title VIII of the Civil Rights Act of 1968 (42 U.S.C. §§ 3601 et seq.), which prohibits discrimination in housing on the basis of race, color, religion, national origin, sex, familial status, or disability;
- iii. Section 504 of the Rehabilitation Act of 1973, as amended (29 U.S.C. § 794), which prohibits discrimination on the basis of disability under any program or activity receiving federal financial assistance;
- iv. The Age Discrimination Act of 1975, as amended (42 U.S.C. §§ 6101 et seq.), and Treasury’s implementing regulations at 31 C.F.R. Part 23, which prohibit discrimination on the basis of age within programs or activities receiving federal financial assistance; and
- v. Title II of the Americans with Disabilities Act of 1990, as amended (42 U.S.C. §§ 12101 et seq.), which prohibits discrimination on the basis of disability under programs, activities, and services provided or made available by state and local governments or instrumentalities or agencies thereto.

¹ 22 C.F.R. § 22.3 defines “program” and “activity” as all operations of an entity, including local governments, that receive Federal financial assistance, and the departments, agencies, or special purpose districts of the local governments to which Federal financial assistance is distributed. “Federal financial assistance” includes, among other things, grants and loans of federal funds. “Facility” includes all or any part of structures, equipment, or other real or personal property or interests therein, and the provision of facilities includes the construction, expansion, renovation, remodeling, alteration, or acquisition of facilities.

II. Discriminatory Practices Prohibited in the Administration of the ARP/CSLFRF Award

To ensure compliance with Title VII of the Civil Rights Act of 1964, and Title 31 Code of Federal Regulations, Part 22, the Civil Rights Restoration Act of 1987, and other pertinent nondiscrimination authorities, the County shall prohibit, at a minimum, the following practices in its administration of CSLFRF pursuant to the ARP/CSLFRF award:

1. Denying to a person any service, financial aid, or other program benefit without good cause;
2. Providing to a person any service, financial aid, or another benefit which is different in quantity or quality, or is provided in a different manner, from that provided to others under the program.
3. Subjecting a person to segregation or separate treatment in any matter related to the receipt of any service, financial aid, or other benefit under the program;
4. Restricting a person in the enjoyment of any advantages, privileges, or other benefits enjoyed by others receiving any service, financial aid, or other benefit under the program;
5. Treating a person differently from others in determining whether that person satisfies any admission, enrollment, quota, eligibility, membership, or other requirement or condition which persons must meet to be provided any service, financial aid, or other benefit provided under the program;
6. Implementing different standards, criteria, or other requirements for admission, enrollment, or participation in planning, advisory, contractual, or other integral activities to the program;
7. Adopting methods of administration which, directly or through contractual relationships, would defeat or substantially impair the accomplishment of effective nondiscrimination;
8. Selecting a site or location of facilities with the purpose or effect of excluding persons from, denying them the benefits of, subjecting them to discrimination, or with the purpose or effect of defeating or substantially impairing the accomplishment of the objectives of Title VI or related acts and regulations;
9. Discriminating against any person, either directly or through a contractual agreement, in any employment resulting from the program, a primary objective of which is to provide employment;
10. Committing acts of intimidation or retaliation, including threatening, coercing, or discriminating against any individual for the purpose of interfering with any right or privilege secured by any pertinent nondiscrimination law, or because an individual made a complaint, testified, assisted, or participated in an investigation, proceeding, or hearing.

III. Reporting & Enforcement

1. The County shall cooperate in any enforcement or compliance review activities by the Department of the Treasury. Enforcement may include investigation, arbitration, mediation, litigation, and monitoring of any settlement agreements that may result from these actions. The County shall comply with information requests, on-site compliance reviews, and reporting requirements.
2. The County shall maintain a complaint log and inform the Treasury of any complaints of discrimination on the grounds of race, color, or national origin (including limited English proficiency covered by Title VI of the Civil Rights Act of 1964 and implementing

regulations and provide, upon request, a list of all such reviews or proceedings based on the complaint, whether pending or completed, including the outcome. The County shall inform the Treasury if it has received no complaints under Title VI.

3. Any person who believes they have been aggrieved by a discriminatory practice under Title VI has a right to file a formal complaint with the Treasury. Any such complaint must be in writing and filed with the Treasury's Title VI Coordinator within one hundred eighty (180) days following the date of the alleged discriminatory occurrence.
4. Any person who believes that because of that person's race, color, national origin, limited English proficiency, familial status, sex, age, religion, or disability that he/she/they have been discriminated against or unfairly treated by the County in violation of this policy should contact the following office within 180 days from the date of the alleged discriminatory occurrence:

Robert L. Outten, County Manager
Email: outten@darenc.com
Phone: 252.475.5800
Fax: 252.473.1817
Mailing Address:
P.O. Box 1000, Manteo, NC 27954

PROPERTY MANAGEMENT POLICY FOR THE EXPENDITURE OF AMERICAN RESCUE PLAN ACT OF 2021 CORONAVIRUS STATE AND LOCAL FISCAL RECOVERY FUNDS BY THE COUNTY OF DARE, NC

WHEREAS the County of Dare, NC has received an allocation of funds from the Coronavirus State and Local Fiscal Recovery Funds of H.R. 1319 American Rescue Plan Act of 2021 (ARP/CSLFRF); and

WHEREAS the funds may be used for projects within these categories, to the extent authorized by state law.

1. Support COVID-19 public health expenditures, by funding COVID-19 mitigation and prevention efforts, medical expenses, behavioral healthcare, preventing and responding to violence, and certain public health and safety staff;
2. Address negative economic impacts caused by the public health emergency, including economic harms to households, small businesses, non-profits, impacted industries, and the public sector;
3. Replace lost public sector revenue, using this funding to provide government services to the extent of the reduction in revenue experienced due to the pandemic;
4. Provide premium pay for essential workers, offering additional support to those who have borne and will bear the greatest health risks because of their service in critical infrastructure sectors; and,
5. Invest in water, sewer, and broadband infrastructure, making necessary investments to improve access to clean drinking water, support vital wastewater and stormwater infrastructure, and to expand access to broadband internet; and

WHEREAS the ARP/CSLFRF are subject to the provisions of the federal Uniform Grant Guidance, 2 CFR Sect. 200 (UG), as provided in the Assistance Listing; and

WHEREAS the Compliance and Reporting Guidance for the State and Local Fiscal Recovery Funds (v3.0 February 2022) provides, in relevant part:

Equipment and Real Property Management. Any purchase of equipment or real property with SLFRF funds must be consistent with the Uniform Guidance at 2 CFR Part 200, Subpart D. Equipment and real property acquired under this program must be used for the originally authorized purpose. Consistent with 2 CFR 200.311 and 2 CFR 200.313, any equipment or real property acquired using SLFRF funds shall vest in the non-Federal entity. Any acquisition and maintenance of equipment or real property must also be in compliance with relevant laws and regulations.

WHEREAS Subpart D of the UG dictates title, use, management, and disposal of real property, equipment, and supplies acquired in whole or in part with ARP/CSLFRF;

BE IT RESOLVED that the governing board of the County of Dare, NC hereby adopts and enacts the following Property Management Policy for the expenditure of ARP/CSLFRF.

Adopted this 6th day of June, 2022.

Chairman, Board of County Commissioners

[SEAL]
COUNTY OF DARE, NORTH CAROLINA

Clerk to the Board

County of Dare, NC
Property Management Policy for Real Property, Equipment, and Supplies Acquired with
American Rescue Plan Act of 2021 Coronavirus State and Local Fiscal Recovery Funds

I. POLICY OVERVIEW

Title 2 U.S. Code of Federal Regulations Part 200, Uniform Administrative Requirements, Cost Principles, and Audit Requirements for Federal Awards, commonly called Uniform Guidance (UG), specifically Subpart D, details post award requirements related to property management of property acquired or updated, in whole or in part, with funds from the Coronavirus State and Local Fiscal Recovery Funds of H.R. 1319 American Rescue Plan Act of 2021 (ARP/CSLFRF).

2 CFR 200.311 through 2 CFR 200.316 detail property standards related to the expenditure of ARP/CLSFRF funds. The County of Dare, NC (County) shall adhere to all applicable property standards, as detailed below.

II. DEFINITIONS

The definitions in 2 CFR 200.1 apply to this policy, including the following:

Computing devices: machines used to acquire, store, analyze, process, and publish data and other information electronically, including accessories (or “peripherals”) for printing, transmitting and receiving, or storing electronic information. See also the definitions of supplies and information technology systems in this section.

Equipment: tangible personal property (including information technology systems) having a useful life of more than one year and a per-unit acquisition cost which equals or exceeds the lesser of the capitalization level established by the County for financial statement purposes, or \$5,000.

Information technology systems: computing devices, ancillary equipment, software, firmware, and similar procedures, services (including support services), and related resources. See also the definitions of computing devices and equipment in this section.

Intangible property: property having no physical existence, such as trademarks, copyrights, patents and patent applications and property, such as loans, notes and other debt instruments, lease agreements, stock and other instruments of property ownership (whether the property is tangible or intangible).

Personal property: property other than real property. It may be tangible, having physical existence, or intangible.

Property: real property or personal property.

Real property: land, including land improvements, structures and appurtenances thereto, but excludes moveable machinery and equipment.

Supplies: all tangible personal property other than those described in the definition of equipment in this section. A computing device is a supply if the acquisition cost is less than the lesser of the capitalization level established by the County for financial statement purposes or \$5,000, regardless of the length of its useful life. See also the definitions of computing devices and equipment in this section.

III. REAL PROPERTY

Title to Real Property: Title to real property acquired or improved with ARP/CSLFRF vests with the County. 2 CFR 200.311(a).

Use of Real Property: Real property acquired or improved with ARP/CSLFRF must be used for the originally authorized purpose as long as needed for that purpose, during which time the County must not dispose of or encumber its title or other interests. 2 CFR 200.311(b).

Insurance of Real Property: The County must provide the equivalent insurance coverage for real property acquired or improved with ARP/CSLFRF provided to property owned by the County. 2 CFR 200.310.

Disposition of Real Property: When the County no longer needs real property purchased with ARP/CSLFRF for ARP/CSLFRF purposes, the County must obtain disposition instructions from US Treasury. The instructions must provide for one of the following alternatives:

1. The County retains title after compensating US Treasury. The amount paid to US Treasury will be computed by applying US Treasury's percentage of participation in the cost of the original purchase (and costs of any improvements) to the fair market value of the property. However, in those situations where the County is disposing of real property acquired or improved with ARP/CSLFRF and acquiring replacement real property under the ARP/CSLFRF, the net proceeds from the disposition may be used as an offset to the cost of the replacement property.
2. The County sells the property and compensates US Treasury. The amount due to US Treasury will be calculated by applying US Treasury's percentage of participation in the cost of the original purchase (and cost of any improvements) to the proceeds of the sale after deduction of any actual and reasonable selling and fixing-up expenses. If the ARP/CSLFRF award has not been closed out, the net proceeds from sale may be offset against the original cost of the property. When the County is directed to sell property, sales procedures must be followed that provide for competition to the extent practicable and result in the highest possible return.
3. The County transfers title to US Treasury or to a third party designated/approved by US Treasury. The County is entitled to be paid an amount calculated by applying the County's percentage of participation in the purchase of the real property (and cost of any improvements) to the current fair market value of the property. 2 CFR 200.311(c).

IV. EQUIPMENT

Title to Equipment: Title to equipment acquired or improved with ARP/CSLFRF vests with the County. 2 CFR 200.313(a).

Use of Equipment: The County must use equipment acquired with ARP/CSLFRF for the project for which it was acquired as long as needed, whether or not the project continues to be supported by the ARP/CSLFRF award, and the County must not encumber the property without prior approval of US Treasury. 2 CFR 200.313(a)(1)-(2).

When no longer needed for the original project, the equipment may be used in other activities supported by a Federal awarding agency, in the following order of priority:

1. Activities under a Federal award from the Federal awarding agency which funded the original project, then
2. Activities under Federal awards from other Federal awarding agencies. This includes consolidated equipment for information technology systems. 2 CFR 200.313(c)(1).

During the time that equipment is used on the project for which it was acquired, the County must also make equipment available for use on other projects or programs currently or previously supported by the Federal Government, provided that such use will not interfere with the work on the project for which it was originally acquired. First preference for other use must be given to other programs or projects supported by US Treasury and second preference must be given to programs or projects under Federal awards from other Federal awarding agencies. Use for non-federally-funded programs or projects is also permissible. User fees should be considered if appropriate. 2 CFR 200.313(c)(2).

Noncompetition: The County must not use equipment acquired with the ARP/CSLFRF to provide services for a fee that is less than private companies charge for equivalent services unless specifically authorized by Federal statute for as long as the Federal Government retains an interest in the equipment. 2 CFR 200.313(c)(3).

Replacement Equipment: When acquiring replacement equipment, the County may use the equipment to be replaced as a trade-in or sell the property and use the proceeds to offset the cost of the replacement property. 2 CFR 200.313(c)(4).

Management of Equipment: The County will manage equipment (including replacement equipment) acquired in whole or in part with ARP/CSLFRF according to the following requirements.

1. The County will maintain sufficient records that include
 - a) a description of the property,
 - b) a serial number or other identification number,
 - c) the source of funding for the property (including the Federal Award Identification Number (FAIN)),
 - d) who holds title,
 - e) the acquisition date,
 - f) cost of the property,
 - g) percentage of Federal participation in the project costs for the Federal award under which the property was acquired,

- h) the location, use and condition of the property, and
 - i) any ultimate disposition data including the date of disposal and sale price of the property.
2. The County will conduct a physical inventory of the property and reconcile results with its property records at least once every two years.
 3. The County will develop a control system to ensure adequate safeguards to prevent loss, damage, or theft of the property. Any loss, damage, or theft will be investigated by the County.
 4. The County will develop and implement adequate maintenance procedures to keep the property in good condition.
 5. If the County is authorized or required to sell the property, it will establish proper sales procedures to ensure the highest possible return, in accordance with state and federal law.

Insurance of Equipment: The County must provide the equivalent insurance coverage for equipment acquired or improved with ARP/CSLFRF as provided to property owned by the County. 2 CFR 200.310.

Disposition of Equipment: When the equipment is no longer needed for its original ARP/CSLFRF purpose, the County may either make the equipment available for use in other activities funded by a Federal agency, with priority given to activities funded by US Treasury, dispose of the equipment according to instructions from US Treasury, or follow the procedures below. 2 CFR 200.313(e).

1. Equipment with a per-item fair market value of less than \$5,000 may be retained, sold or transferred by the County, in accordance with state law, with no additional responsibility to US Treasury;
2. If no disposal instructions are received from US Treasury, equipment with a per-item fair market value of greater than \$5,000 may be retained or sold by the County. The County must establish proper sales procedures, in accordance with state law, to ensure the highest possible return. The County must reimburse US Treasury for its federal share. Specifically, US Treasury is entitled to an amount calculated by multiplying the current market value or proceeds from sale by the ARP/CSLFRF funding percentage of participation in the cost of the original purchase. If the equipment is sold, US Treasury may permit the County to deduct and retain from the Federal share \$500 or ten percent of the proceeds, whichever is less, for its selling and handling expenses.
3. Equipment may be transferred to US Treasury or to a third-party designated by US Treasury in return for compensation to the County for its attributable compensation for its attributable percentage of the current fair market value of the property.

V. SUPPLIES

Title to Supplies. Title to supplies acquired with ARP/CSLFRF vests with the County upon acquisition. 2 CFR 200.314(a).

Use and Disposition of Supplies: If there is a residual inventory of unused supplies exceeding \$5,000 in total aggregate value upon termination or completion of the ARP/CSLFRF project and the supplies are not needed for any other Federal award, the County must retain the supplies for use on other activities or sell them, but must, in either case, compensate the Federal Government for its share. The amount of compensation must be computed in the same manner as for equipment. 2 CFR 200.314(a).

Noncompetition. As long as the Federal Government retains an interest in the supplies, the County must not use supplies acquired under the ARP/CSLFRF to provide services to other organizations for a fee that is less than private companies charge for equivalent services, unless specifically authorized by Federal statute. 2 CFR 200.314(b).

VI. PROPERTY TRUST RELATIONSHIP

Real property, equipment, and intangible property, that are acquired or improved with ARP/CSLFRF must be held in trust by the County as trustee for the beneficiaries of the project or program under which the property was acquired or improved. US Treasury may require the County to record liens or other appropriate notices of record to indicate that personal or real property has been acquired or improved with a Federal award and that use and disposition conditions apply to the property. 2 CFR 200.316.

VII. IMPLEMENTATION OF POLICY

The Finance department shall adopt procedures to track all real property, equipment, and supplies (collectively, property) acquired or improved in whole or in part with ARP/CLSFRR funds. At a minimum, those procedures must address the following:

- Ensure proper insurance of property
- Document proper use of property
- Record and maintain required data records for equipment
- Conduct periodic inventories of equipment, at least every two years
- Create processes for replacement and disposition of property
- Establish other internal controls to safeguard and properly maintain property

VIII. POLICY AUTHORITY

Following initial adoption of this policy by the governing board, the Finance Director is hereby authorized to administer, enforce, and make revisions to this policy.



Amendment to Grant Project Ordinance for American Rescue Plan SLFRF Grant

Description

This amendment:

- 1) Reduces the total by \$7,924 which adjusts to actual interest earnings on the grant funds as of 2/28/2022; and
- 2) Moves \$71,866 of claimed costs (salaries) from Emergency Management to Sheriff.

This will exclude the entirety of Emergency Management grants for which salaries can be claimed and is the safest path to follow for audit purposes.

Board Action Requested

Adopt amendment to the grant project ordinance.

Item Presenter

David Clawson, Finance Director

**County of Dare, North Carolina
Grant Project Ordinance
for
American Rescue Plan State and Local Fiscal Recovery Funds**

BE IT ORDAINED by the Board of Commissioners of the County of Dare, North Carolina that, pursuant to Section 13.2 of Chapter 159 of the General Statutes of North Carolina, the following grant project ordinance is hereby adopted:

Section 1 This ordinance amends the budget established on 2/22/2022 for the County grant award of American Rescue Plan State and Local Fiscal Recovery Funds (SLFRF). Eligible expenditures must be incurred during 3/11/2021 through 12/31/2026. The County expended the grant on eligible salaries and fringes from 7/1/2021 through 2/28/2022. This amendment adjusts interest income to actual as of 2/28/2022, reduces Emergency Management salaries, and increases Sheriff salaries. Emergency Management salaries claimed were reduced as a precaution by excluding the total amount of Emergency Management grants for which salaries can be claimed.

Section 2 The following budget shall be conducted within the American Rescue Plan Fund (fund #27), a Special Revenue Fund. The level of budgetary control for expenditures for the SLFRF grant is the total of the grant plus interest income.

Section 3 The following appropriations are changed as indicated:

Public Safety Salaries & Fringes:

Sheriff		
Salaries	274510-500200	\$63,942 increase
Emergency Management		
Salaries	274542-500200	\$71,866 decrease

Section 5 The following revenues are anticipated to be available are changed as indicated:

Restricted investment earnings	273025-450100	\$7,924 decrease
--------------------------------	---------------	------------------

Section 6 The Finance Officer is directed to report the financial status of the project as a part of the normal financial reporting processes.

Section 7 The American Rescue Plan Fund is a multi-year Special Revenue Fund for non-recurring activities. All funds are appropriated pursuant to section 13.2 of Chapter 159 of the NCGS, therefore, appropriations do not lapse at the end of the fiscal year. The County's has reported all eligible expenditures as of March 31, 2022, and will close out the grant and the fund as of June 30, 2022.

Section 8 Copies of this grant project ordinance shall be furnished to the Budget Officer, the Finance Officer and to the Clerk to the Board of Commissioners.

Adopted this 6th day of June, 2022

Chairman, Board of Commissioners

[SEAL]

Cheryl Anby, Clerk to the Board of Commissioners



***North Carolina U.N.C. Greensboro Grant Application
"Dare County Sheriff's Office Regional Human Trafficking Task Force"***

Description

The Dare County Sheriff's Office is requesting approval to apply for a three year, no cash match grant. The total grant for the three year period will be \$750,299.00 with an "in-kind" match of \$187,910.00 and the fund amount will be \$562,389.00.

The grantees will be the Sheriff's Office and the Outer Banks Hotline.

This will involve investigation, officer training, crisis intervention and other items to facilitate the Task Force.

Board Action Requested

Approval

Item Presenter

none



*NC Department of Transportation
ADA Compliant Curb Ramps*

Description

Upgrades to curb ramps for Dare County in the communities of Rodanthe, Waves, Salvo, Avon and Buxton by the NC Department of Transportation at no cost. See attached letter and GIS maps for location.

Board Action Requested

Take appropriate action

Item Presenter

Robert Outten, County Manager



STATE OF NORTH CAROLINA
DEPARTMENT OF TRANSPORTATION

ROY COOPER
GOVERNOR

J. ERIC BOYETTE
SECRETARY

May 18, 2022

Robert Outten
P.O. Box 1000
Manteo, NC 27954

Re: Upgrades to Curb ramps for Dare County (Communities of Rodanthe, Waves, Salvo, Avon & Buxton)

Dear Mr. Robert Outten,

The North Carolina Department of Transportation proposes to make improvements at the locations shown on the attached maps by installing, upgrading or retrofitting curb ramps to bring them into compliance with current ADA standards. These improvements will be made using Transportation Alternatives Program (TAP) funding. If site-specific locations along State-maintained routes have not been identified, the area under consideration has been indicated.

To be eligible for TAP funding, projects must have a local government sponsor. Because these locations are all on the State highway system, there is no financial obligation on behalf of the local government.

If there are locations on routes owned and maintained by the municipality that you would like to have addressed, these are eligible as well, however the municipality must provide 20% matching funds. Please include of a list of these specific locations along with this letter.

If you are willing to support improvements at these locations, please have the appropriate local official sign and return this letter by Friday, June 17, 2022.

If you have questions, please contact Barry Hobbs at (252) 482-1862 or wbhobbs@ncdot.gov.

Sincerely,

DocuSigned by:

C. W. Bridgers, Jr., PE
Division Engineer – Division One

The **Dare County (Communities of Rodanthe, Waves, Salvo, Avon & Buxton)** supports the improvements shown on the attached sheets to bring curb ramps at these locations into compliance with current ADA standards.

Printed Name: _____
Title: _____
Signature: _____
Date: _____

Mailing Address:
NC DEPARTMENT OF TRANSPORTATION
DIVISION ONE
113 AIRPORT DRIVE, SUITE 100
EDENTON, NC 27932

Telephone: (252) 482-1850
Fax: (252) 482-8722
Customer Service: 1-877-368-4968

Location:
113 AIRPORT DRIVE, SUITE 100
EDENTON, NC 27932

Website: www.ncdot.gov

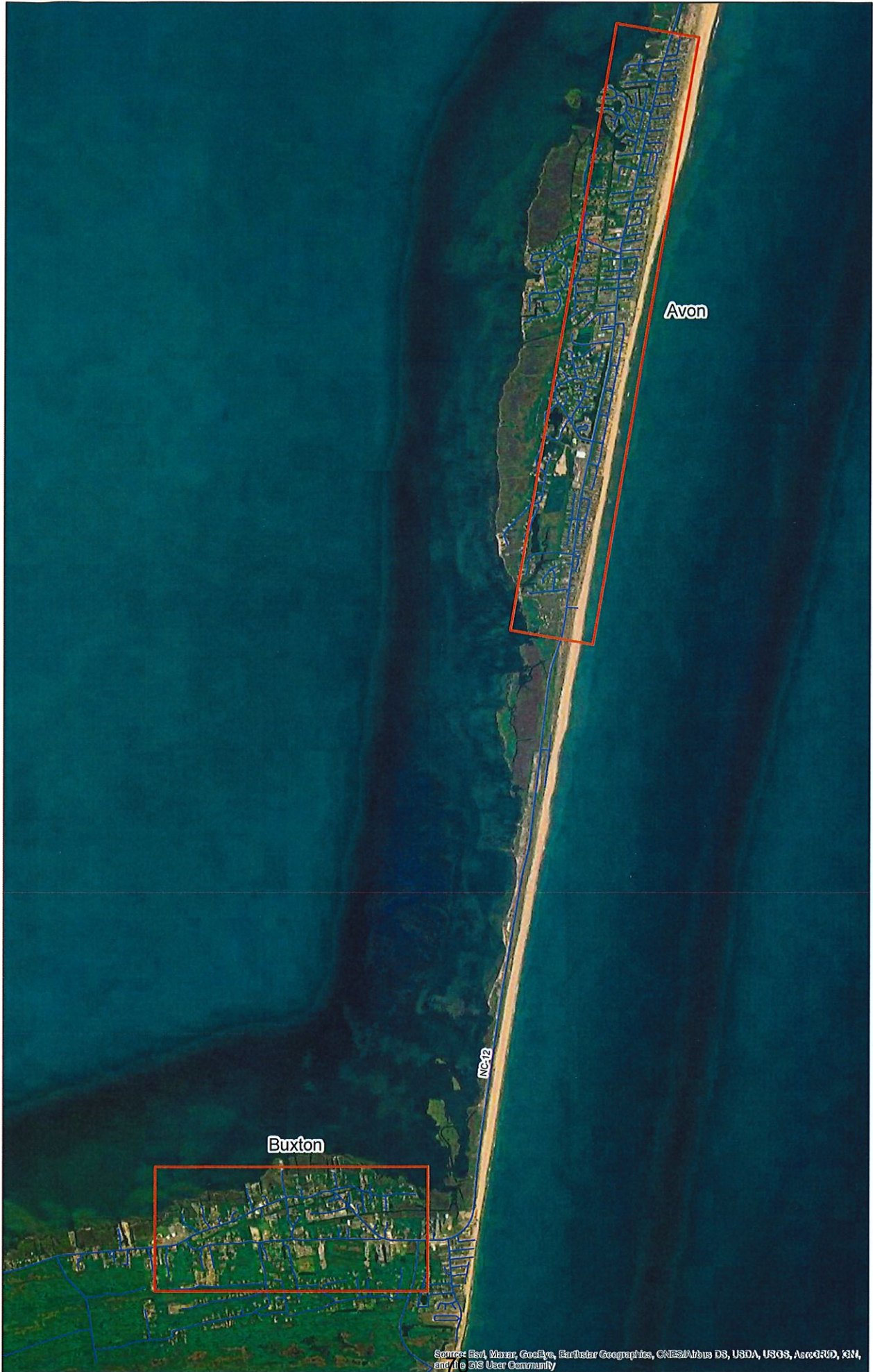

Avon

Buxton

NC-12

Rodanthe, Waves & Salvo

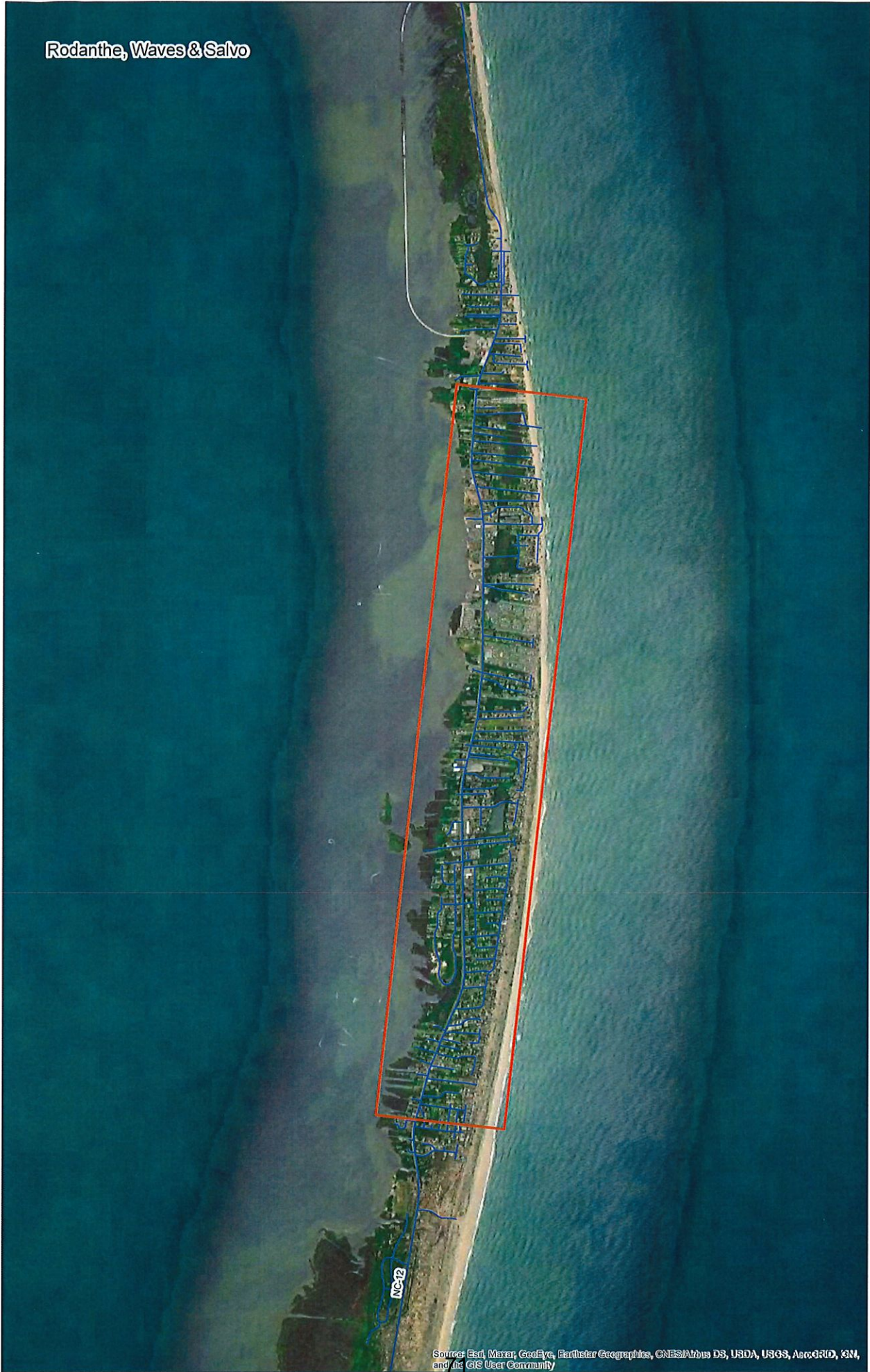



Avon Property Owners Association "Fourth of July" 2022 Fireworks Display

Description

Avon Property Owners Association and produced by Pyrotecnico-Vitale Family Firework Inc. have applied for a permit to conduct a fireworks display on July 4, 2022, at the Avon Fishing Pier. Pyrtocnico has submitted all needed paperwork for the issuance of the required County permit per NCGS 14-413. Fire Marshal Kovacs will be on-site to conduct the required fire inspection and issue the required operational permit for the show per North Carolina Fire Code requirements.

Board Action Requested

Approval of the permit.

Item Presenter

Steven Kovacs, Deputy Director of Emergency Management/Fire Marshal



COUNTY OF DARE

Department of Emergency Management
Office of the Fire Marshal

P.O. Box 1000, Manteo, North Carolina, 27954

Firework - Permit Application

Show Information

ÁÈÇÈ ÆÈ ÆÈ ÆÈ	Avon Property Owners Association		
ÁÈÇÈ ÆÈ ÇÈ	7/4/22	ÁÈÇÈ ÆÈ ÆÈ	9:15 PM
ÁÈÇÈ ÆÈ ÇÈ	20 mins	ÁÈÇÈ ÆÈ ÇÈ	7/5/22
ÁÈÇÈ ÆÈ ÇÈ ÆÈ	Avon Fishing Pier - 41001 NC Highway 12, Avon, NC 27915		
ÁÈÇÈ ÆÈ ÇÈ ÆÈ	Avon Property Owners Association		
ÇÈÇÈ ÆÈ	PO Box 9		
ÁÈÇÈ ÆÈ	Avon, NC	ÇÈÇÈ	27915
ÁÈÇÈ ÆÈ ÇÈ ÆÈ	Pat Weston		
ÁÈÇÈ ÆÈ		ÁÈÇÈ ÆÈ	
ÁÈÇÈ ÆÈ		ÁÈÇÈ ÆÈ	N/A

Pyrotechnic Contractor

ÁÈÇÈ ÆÈ	Pyrotecnico Fireworks, Inc.	ÁÈÇÈ ÆÈ ÇÈ ÆÈ	8-PA-073-23-4J-12122
ÇÈÇÈ ÆÈ	PO Box 149		
ÁÈÇÈ ÆÈ	New Castle	ÁÈÇÈ ÆÈ	PRA
ÁÈÇÈ ÆÈ	803.944.4718	ÁÈÇÈ ÆÈ	16103
ÁÈÇÈ ÆÈ	balexander@pyrotecnico.com	ÁÈÇÈ ÆÈ	N/A
ÁÈÇÈ ÆÈ ÇÈ ÆÈ	Britany Alexander		ÁÈÇÈ ÆÈ

Technician Information

<i>Operator</i>			
ÁÈÇÈ ÆÈ	Kenneth Polk	ÁÈÇÈ ÆÈ ÇÈ ÆÈ	
ÁÈÇÈ ÆÈ		ÁÈÇÈ ÆÈ	
ÁÈÇÈ ÆÈ		ÁÈÇÈ ÆÈ	
<i>Assistants</i>			
ÁÈÇÈ ÆÈ	see attached list	ÁÈÇÈ ÆÈ ÇÈ ÆÈ	
ÁÈÇÈ ÆÈ		ÁÈÇÈ ÆÈ ÇÈ ÆÈ	

Site Information (Load in site)

ÁÈÇÈ ÆÈ ÇÈ ÆÈ	See attached timeline		
ÇÈÇÈ ÆÈ			
ÁÈÇÈ ÆÈ		ÁÈÇÈ ÆÈ	
ÁÈÇÈ ÆÈ		ÁÈÇÈ ÆÈ	
ÁÈÇÈ ÆÈ		ÁÈÇÈ ÆÈ	
ÁÈÇÈ ÆÈ ÇÈ ÆÈ		ÁÈÇÈ ÆÈ	

Barge Operator

ÁÈÇÈ ÆÈ ÇÈ ÆÈ	N/A		
ÇÈÇÈ ÆÈ			
ÁÈÇÈ ÆÈ		ÁÈÇÈ ÆÈ	
ÁÈÇÈ ÆÈ		ÁÈÇÈ ÆÈ	
ÁÈÇÈ ÆÈ		ÁÈÇÈ ÆÈ	
ÁÈÇÈ ÆÈ ÇÈ ÆÈ		ÁÈÇÈ ÆÈ	



**Display Information
Avon Property 7/4/22**

Applicant:
Pyrotecnico Fireworks, Inc.
PO Box 149 New Castle, PA 16103

Contact: Britany Alexander | [REDACTED]
balexander@pyrotecnico.com
Production Coordinator

Event: Avon Property Owners Association
Display Location: Avon Fishing Pier - 41001 NC Highway 12, Avon, NC 27915
Display Date: July 4th, 2022
Show Time: 9:15 PM

Pyrotechnicians:
Kenneth Polk | Lead Technician | [REDACTED]

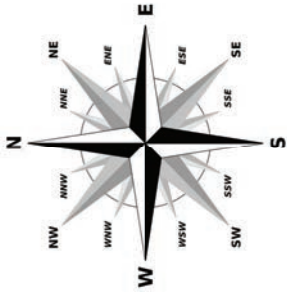

**Avon Property Owners
Association
Fireworks Display Site
Plan**

Avon Fishing Pier
41001 NC-12
Avon, NC 27915

LAT / LONG
35°20'50.29" N
75°29'57.32" W

REVISED DATE: 01.17.2022

DRAWN BY:
Justin Pruet

NOTES:

Site plan is drawn to an approximate scale using NFPA 1123, NFPA 1126 or NFPA 160 as applicable.

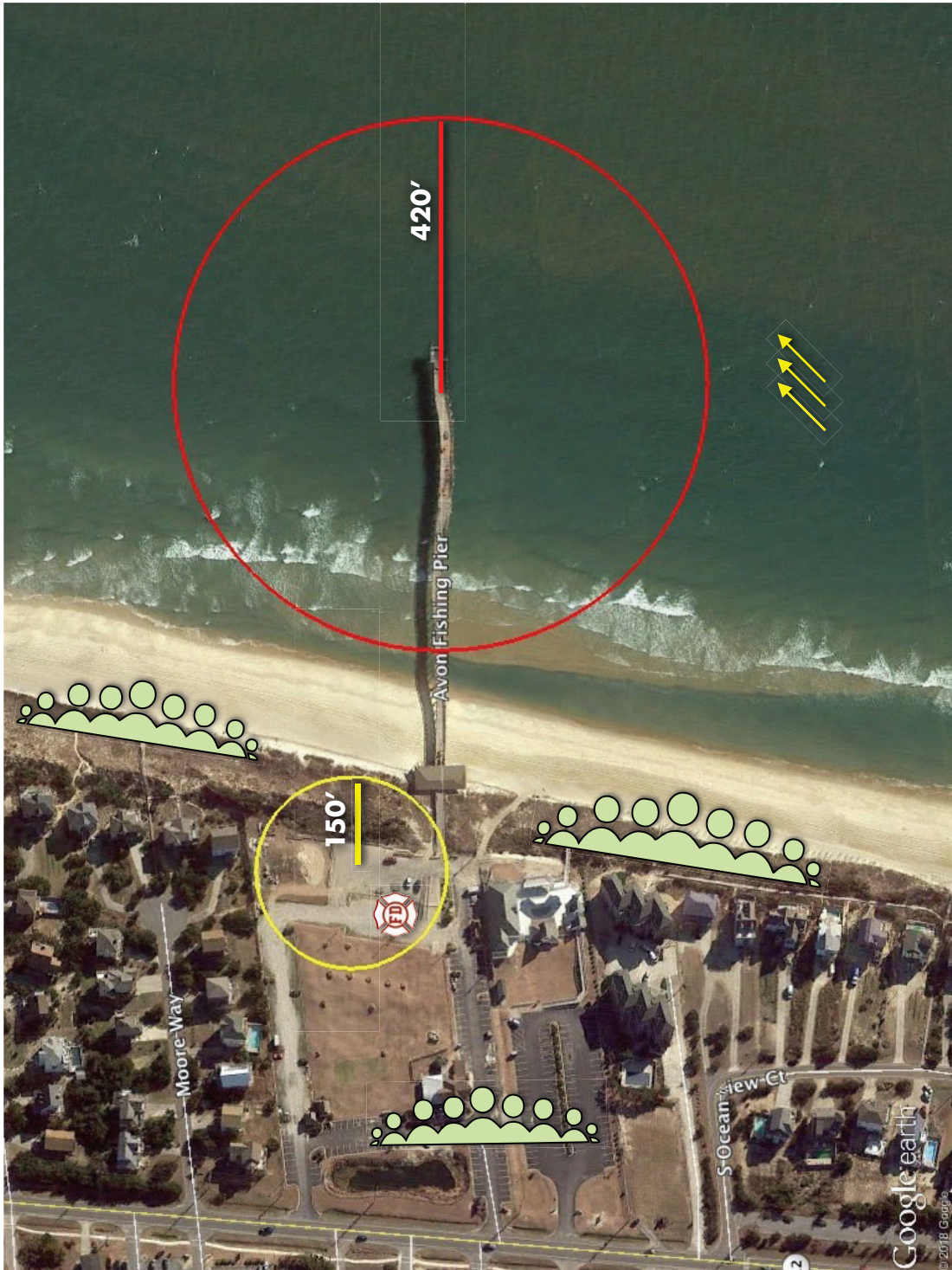
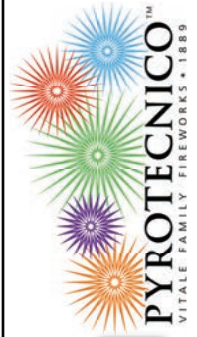

- Audience
- Radius
- Fire
- Wind Direction

420' Safety Fall Out Radius

6" Maximum Device Per Pyrotecnico 100' Per Inch Policy

- Safety Fallout Zone



SHELL / FINALE COUNT TOTALS

Show Date 07/04/2022 / Display Duration: 20 minutes

Sales Order SO-C44327 / Work Order WO-5433

Group	Qty
CAKE FAN	10
FINALE 3IN X 10	30
FINALE 4IN X 6	10
FINALE 5IN X 5	12
IGNITERS	370
SHELL 3IN X 2	36
SHELL 3IN X 5 TD	24
SHELL 4IN	36
SHELL 4IN X 2	36
SHELL 4IN X 6 TD	10
SHELL 5IN	108
SHELL 6IN	45

Holder's Full Name: Kenneth William Polk
Business Name: Pyrotecnico
Government ID By: North Carolina
Government ID Type: Driver License
ID Number: *****5817



License Number: 3115
License Type: 1.3G Pyrotechnic
License Level: Operator
License Status: Valid
Expiration Date: 01/13/2024



License Number: 2163
License Type: 1.3G Pyrotechnic
License Level: Assistant
License Status: Not Renewed
Expiration Date: 11/01/2015

Holder's Full Name: Malissa Jo Polk
Business Name: Pyrotecnico
Government ID By: North Carolina
Government ID Type: Driver License
ID Number: ***1797



License Number: 3116
License Type: 1.3G Pyrotechnic
License Level: Operator
License Status: Valid
Expiration Date: 01/13/2024



License Number: 2162
License Type: 1.3G Pyrotechnic
License Level: Assistant
License Status: Not Renewed
Expiration Date: 11/01/2015

Holder's Full Name: Jacob Russell
Business Name: Pyrotecnico
Government ID By: Virginia
Government ID Type: Driver License
ID Number: *****8964

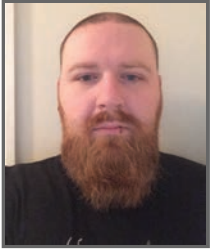

License Number: 3588
License Type: 1.3G Pyrotechnic
License Level: Assistant
License Status: Valid
Expiration Date: 07/31/2021



**Avon Property 7/4/22
Technician Information**

Technician

Name: Lead: Kenneth Polk



NC Op Lic #: 3115

Name: Malissa Polk

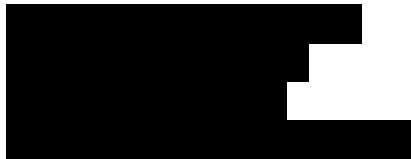

NC Op Lic #: 3116

Assistants

Name: Richie Babbitt

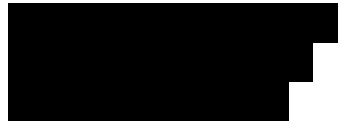

NC Asst Op Lic #:

Name: Michael Witton

Name: Jacob Russell

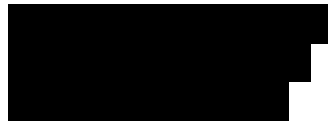

NC Asst Op Lic #: 3588

No one will be on site without a NC License or NC OSFM Day Pass and Drivers License.



CERTIFICATE OF LIABILITY INSURANCE

DATE (MM/DD/YYYY)

2/14/2022

THIS CERTIFICATE IS ISSUED AS A MATTER OF INFORMATION ONLY AND CONFERS NO RIGHTS UPON THE CERTIFICATE HOLDER. THIS CERTIFICATE DOES NOT AFFIRMATIVELY OR NEGATIVELY AMEND, EXTEND OR ALTER THE COVERAGE AFFORDED BY THE POLICIES BELOW. THIS CERTIFICATE OF INSURANCE DOES NOT CONSTITUTE A CONTRACT BETWEEN THE ISSUING INSURER(S), AUTHORIZED REPRESENTATIVE OR PRODUCER, AND THE CERTIFICATE HOLDER.

IMPORTANT: If the certificate holder is an ADDITIONAL INSURED, the policy(ies) must be endorsed. If SUBROGATION IS WAIVED, subject to the terms and conditions of the policy, certain policies may require an endorsement. A statement on this certificate does not confer rights to the certificate holder in lieu of such endorsement(s).

PRODUCER Britton-Gallagher and Associates, Inc. One Cleveland Center, Floor 30 1375 East 9th Street Cleveland OH 44114	CONTACT NAME: PHONE (A/C. No. Ext): 216-658-7100		FAX (A/C. No.): 216-658-7101
	E-MAIL ADDRESS: info@brittongallagher.com		
INSURER(S) AFFORDING COVERAGE			NAIC #
INSURED Pyrotecnico Fireworks Inc. P.O. Box 149 299 Wilson Road New Castle PA 16103	2299	INSURER A : Everest Indemnity Insurance Co.	10851
		INSURER B : Everest Denali Insurance Company	16044
		INSURER C : Arch Speciality Ins Co	21199
		INSURER D :	
		INSURER E :	
		INSURER F :	

COVERAGES

CERTIFICATE NUMBER: 2077359228

REVISION NUMBER:

THIS IS TO CERTIFY THAT THE POLICIES OF INSURANCE LISTED BELOW HAVE BEEN ISSUED TO THE INSURED NAMED ABOVE FOR THE POLICY PERIOD INDICATED. NOTWITHSTANDING ANY REQUIREMENT, TERM OR CONDITION OF ANY CONTRACT OR OTHER DOCUMENT WITH RESPECT TO WHICH THIS CERTIFICATE MAY BE ISSUED OR MAY PERTAIN, THE INSURANCE AFFORDED BY THE POLICIES DESCRIBED HEREIN IS SUBJECT TO ALL THE TERMS, EXCLUSIONS AND CONDITIONS OF SUCH POLICIES. LIMITS SHOWN MAY HAVE BEEN REDUCED BY PAID CLAIMS.

INSR LTR	TYPE OF INSURANCE	ADDL INSR	SUBR WVD	POLICY NUMBER	POLICY EFF (MM/DD/YYYY)	POLICY EXP (MM/DD/YYYY)	LIMITS
A	GENERAL LIABILITY <input checked="" type="checkbox"/> COMMERCIAL GENERAL LIABILITY <input type="checkbox"/> CLAIMS-MADE <input checked="" type="checkbox"/> OCCUR GEN'L AGGREGATE LIMIT APPLIES PER: <input type="checkbox"/> POLICY <input checked="" type="checkbox"/> PRO-JECT <input type="checkbox"/> LOC	Y	Y	SI8ML00891-221	1/14/2022	1/14/2023	EACH OCCURRENCE \$ 1,000,000 DAMAGE TO RENTED PREMISES (Ea occurrence) \$ 500,000 MED EXP (Any one person) \$ PERSONAL & ADV INJURY \$ 1,000,000 GENERAL AGGREGATE \$ 2,000,000 PRODUCTS - COMP/OP AGG \$ 2,000,000 \$
B	AUTOMOBILE LIABILITY <input checked="" type="checkbox"/> ANY AUTO <input type="checkbox"/> ALL OWNED AUTOS <input type="checkbox"/> SCHEDULED AUTOS <input checked="" type="checkbox"/> HIRED AUTOS <input checked="" type="checkbox"/> NON-OWNED AUTOS	Y	Y	SI8CA00141-221	1/14/2022	1/14/2023	COMBINED SINGLE LIMIT (Ea accident) \$ 1,000,000 BODILY INJURY (Per person) \$ BODILY INJURY (Per accident) \$ PROPERTY DAMAGE (Per accident) \$ \$
C	UMBRELLA LIAB <input checked="" type="checkbox"/> OCCUR <input checked="" type="checkbox"/> EXCESS LIAB <input type="checkbox"/> CLAIMS-MADE DED RETENTION \$	Y	Y	UXP1035252-02	1/14/2022	1/14/2023	EACH OCCURRENCE \$ 4,000,000 AGGREGATE \$ 4,000,000 \$
	WORKERS COMPENSATION AND EMPLOYERS' LIABILITY ANY PROPRIETOR/PARTNER/EXECUTIVE OFFICER/MEMBER EXCLUDED? (Mandatory in NH) <input type="checkbox"/> Y/N If yes, describe under DESCRIPTION OF OPERATIONS below		N/A				<input type="checkbox"/> WC STATUTORY LIMITS <input type="checkbox"/> OTHER E.L. EACH ACCIDENT \$ E.L. DISEASE - EA EMPLOYEE \$ E.L. DISEASE - POLICY LIMIT \$
A	Excess Liability #2	Y	Y	SI8EX01314-221	1/14/2022	1/14/2023	Each Occ/ Aggregate \$5,000,000 Total Limits \$10,000,000

DESCRIPTION OF OPERATIONS / LOCATIONS / VEHICLES (Attach ACORD 101, Additional Remarks Schedule, if more space is required)

Additional Insured extension of coverage is provided by above referenced General Liability policy where required by written agreement.

Fireworks Display Date: July 4, 2022 Rain Date: July 5, 2022

Location: Avon Fishing Pier, 41001 NC 12, Avon, NC 27915

Additional Insured: Avon Property Owners Association, Inc. (APOA); Avon Fishing Pier, 41001 NC 12, Avon, NC 27915; United States of America and the National Park Service; Dare County Tourism Board; County of Dare, NC; Koru Village, Inc.; Avon Fireworks Committee

CERTIFICATE HOLDER**CANCELLATION**
 Avon Property Owners Association, Inc.
 P. O. Box 9
 Avon NC 27915

SHOULD ANY OF THE ABOVE DESCRIBED POLICIES BE CANCELLED BEFORE THE EXPIRATION DATE THEREOF, NOTICE WILL BE DELIVERED IN ACCORDANCE WITH THE POLICY PROVISIONS.

AUTHORIZED REPRESENTATIVE

© 1988-2010 ACORD CORPORATION. All rights reserved.



CERTIFICATE OF LIABILITY INSURANCE

DATE (MM/DD/YYYY)

2/14/2022

THIS CERTIFICATE IS ISSUED AS A MATTER OF INFORMATION ONLY AND CONFERS NO RIGHTS UPON THE CERTIFICATE HOLDER. THIS CERTIFICATE DOES NOT AFFIRMATIVELY OR NEGATIVELY AMEND, EXTEND OR ALTER THE COVERAGE AFFORDED BY THE POLICIES BELOW. THIS CERTIFICATE OF INSURANCE DOES NOT CONSTITUTE A CONTRACT BETWEEN THE ISSUING INSURER(S), AUTHORIZED REPRESENTATIVE OR PRODUCER, AND THE CERTIFICATE HOLDER.

IMPORTANT: If the certificate holder is an ADDITIONAL INSURED, the policy(ies) must be endorsed. If SUBROGATION IS WAIVED, subject to the terms and conditions of the policy, certain policies may require an endorsement. A statement on this certificate does not confer rights to the certificate holder in lieu of such endorsement(s).

PRODUCER Britton-Gallagher and Associates, Inc. One Cleveland Center, Floor 30 1375 East 9th Street Cleveland OH 44114	CONTACT NAME: PHONE (A/C. No. Ext): 216-658-7100		FAX (A/C. No.): 216-658-7101
	E-MAIL ADDRESS: info@brittongallagher.com		
INSURER(S) AFFORDING COVERAGE			NAIC #
INSURED Pyrotecnico Fireworks Inc. P.O. Box 149 299 Wilson Road New Castle PA 16103	INSURER A : Everest Indemnity Insurance Co.		10851
	INSURER B : Everest Denali Insurance Company		16044
	INSURER C : Arch Speciality Ins Co		21199
	INSURER D :		
	INSURER E :		
INSURER F :			

COVERAGES

CERTIFICATE NUMBER: 665488839

REVISION NUMBER:

THIS IS TO CERTIFY THAT THE POLICIES OF INSURANCE LISTED BELOW HAVE BEEN ISSUED TO THE INSURED NAMED ABOVE FOR THE POLICY PERIOD INDICATED. NOTWITHSTANDING ANY REQUIREMENT, TERM OR CONDITION OF ANY CONTRACT OR OTHER DOCUMENT WITH RESPECT TO WHICH THIS CERTIFICATE MAY BE ISSUED OR MAY PERTAIN, THE INSURANCE AFFORDED BY THE POLICIES DESCRIBED HEREIN IS SUBJECT TO ALL THE TERMS, EXCLUSIONS AND CONDITIONS OF SUCH POLICIES. LIMITS SHOWN MAY HAVE BEEN REDUCED BY PAID CLAIMS.

INSR LTR	TYPE OF INSURANCE	ADDL INSR	SUBR WVD	POLICY NUMBER	POLICY EFF (MM/DD/YYYY)	POLICY EXP (MM/DD/YYYY)	LIMITS	
A	GENERAL LIABILITY <input checked="" type="checkbox"/> COMMERCIAL GENERAL LIABILITY <input type="checkbox"/> CLAIMS-MADE <input checked="" type="checkbox"/> OCCUR GEN'L AGGREGATE LIMIT APPLIES PER: <input type="checkbox"/> POLICY <input checked="" type="checkbox"/> PRO-JECT <input type="checkbox"/> LOC	Y	Y	SI8ML00891-221	1/14/2022	1/14/2023	EACH OCCURRENCE	\$ 1,000,000
							DAMAGE TO RENTED PREMISES (Ea occurrence)	\$ 500,000
							MED EXP (Any one person)	\$
							PERSONAL & ADV INJURY	\$ 1,000,000
							GENERAL AGGREGATE	\$ 2,000,000
							PRODUCTS - COMP/OP AGG	\$ 2,000,000
								\$
B	AUTOMOBILE LIABILITY <input checked="" type="checkbox"/> ANY AUTO <input type="checkbox"/> ALL OWNED AUTOS <input checked="" type="checkbox"/> HIRED AUTOS <input type="checkbox"/> SCHEDULED AUTOS <input checked="" type="checkbox"/> NON-OWNED AUTOS	Y	Y	SI8CA00141-221	1/14/2022	1/14/2023	COMBINED SINGLE LIMIT (Ea accident)	\$ 1,000,000
							BODILY INJURY (Per person)	\$
							BODILY INJURY (Per accident)	\$
							PROPERTY DAMAGE (Per accident)	\$
								\$
C	UMBRELLA LIAB <input checked="" type="checkbox"/> OCCUR <input checked="" type="checkbox"/> EXCESS LIAB <input type="checkbox"/> CLAIMS-MADE DED <input type="checkbox"/> RETENTION \$	Y	Y	UXP1035252-02	1/14/2022	1/14/2023	EACH OCCURRENCE	\$ 4,000,000
							AGGREGATE	\$ 4,000,000
								\$
	WORKERS COMPENSATION AND EMPLOYERS' LIABILITY ANY PROPRIETOR/PARTNER/EXECUTIVE OFFICER/MEMBER EXCLUDED? (Mandatory in NH) <input type="checkbox"/> Y/N If yes, describe under DESCRIPTION OF OPERATIONS below		N/A				WC STATUTORY LIMITS	OTHER
							E.L. EACH ACCIDENT	\$
							E.L. DISEASE - EA EMPLOYEE	\$
							E.L. DISEASE - POLICY LIMIT	\$
A	Excess Liability #2	Y	Y	SI8EX01314-221	1/14/2022	1/14/2023	Each Occ/ Aggregate Total Limits	\$5,000,000 \$10,000,000

DESCRIPTION OF OPERATIONS / LOCATIONS / VEHICLES (Attach ACORD 101, Additional Remarks Schedule, if more space is required)

Additional Insured extension of coverage is provided by above referenced General Liability policy where required by written agreement.
 Avon Property Owners Association, Inc. Fireworks Display Date: July 4, 2022 Rain Date: July 5, 2022
 Avon Property Owners Association, Inc. Fireworks Display Location: Avon Fishing Pier, 41001 NC 12, Avon, NC 27915
 Additional Insured: Cape Hatteras National Seashore

CERTIFICATE HOLDER**CANCELLATION**

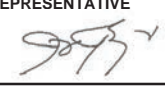
Cape Hatteras National Seashore 1401 National Park Drive Manteo NC 27954	SHOULD ANY OF THE ABOVE DESCRIBED POLICIES BE CANCELLED BEFORE THE EXPIRATION DATE THEREOF, NOTICE WILL BE DELIVERED IN ACCORDANCE WITH THE POLICY PROVISIONS. AUTHORIZED REPRESENTATIVE 
--	---

© 1988-2010 ACORD CORPORATION. All rights reserved.



CERTIFICATE OF LIABILITY INSURANCE

DATE (MM/DD/YYYY)

2/14/2022

THIS CERTIFICATE IS ISSUED AS A MATTER OF INFORMATION ONLY AND CONFERS NO RIGHTS UPON THE CERTIFICATE HOLDER. THIS CERTIFICATE DOES NOT AFFIRMATIVELY OR NEGATIVELY AMEND, EXTEND OR ALTER THE COVERAGE AFFORDED BY THE POLICIES BELOW. THIS CERTIFICATE OF INSURANCE DOES NOT CONSTITUTE A CONTRACT BETWEEN THE ISSUING INSURER(S), AUTHORIZED REPRESENTATIVE OR PRODUCER, AND THE CERTIFICATE HOLDER.

IMPORTANT: If the certificate holder is an ADDITIONAL INSURED, the policy(ies) must be endorsed. If SUBROGATION IS WAIVED, subject to the terms and conditions of the policy, certain policies may require an endorsement. A statement on this certificate does not confer rights to the certificate holder in lieu of such endorsement(s).

PRODUCER Britton-Gallagher and Associates, Inc. One Cleveland Center, Floor 30 1375 East 9th Street Cleveland OH 44114	CONTACT NAME: PHONE (A/C, No, Ext): 216-658-7100		FAX (A/C, No): 216-658-7101
	E-MAIL ADDRESS: info@brittongallagher.com		
INSURER(S) AFFORDING COVERAGE			NAIC #
INSURED Pyrotecnico Fireworks Inc. P.O. Box 149 299 Wilson Road New Castle PA 16103	2299 INSURER A : Everest Indemnity Insurance Co.		10851
	INSURER B : Everest Denali Insurance Company		16044
	INSURER C : Arch Speciality Ins Co		21199
	INSURER D :		
	INSURER E :		
INSURER F :			

COVERAGES

CERTIFICATE NUMBER: 665488839

REVISION NUMBER:

THIS IS TO CERTIFY THAT THE POLICIES OF INSURANCE LISTED BELOW HAVE BEEN ISSUED TO THE INSURED NAMED ABOVE FOR THE POLICY PERIOD INDICATED. NOTWITHSTANDING ANY REQUIREMENT, TERM OR CONDITION OF ANY CONTRACT OR OTHER DOCUMENT WITH RESPECT TO WHICH THIS CERTIFICATE MAY BE ISSUED OR MAY PERTAIN, THE INSURANCE AFFORDED BY THE POLICIES DESCRIBED HEREIN IS SUBJECT TO ALL THE TERMS, EXCLUSIONS AND CONDITIONS OF SUCH POLICIES. LIMITS SHOWN MAY HAVE BEEN REDUCED BY PAID CLAIMS.

INSR LTR	TYPE OF INSURANCE	ADDL INSR	SUBR WVD	POLICY NUMBER	POLICY EFF (MM/DD/YYYY)	POLICY EXP (MM/DD/YYYY)	LIMITS
A	GENERAL LIABILITY <input checked="" type="checkbox"/> COMMERCIAL GENERAL LIABILITY <input type="checkbox"/> CLAIMS-MADE <input checked="" type="checkbox"/> OCCUR GEN'L AGGREGATE LIMIT APPLIES PER: <input type="checkbox"/> POLICY <input checked="" type="checkbox"/> PRO-JECT <input type="checkbox"/> LOC	Y	Y	SI8ML00891-221	1/14/2022	1/14/2023	EACH OCCURRENCE \$ 1,000,000 DAMAGE TO RENTED PREMISES (Ea occurrence) \$ 500,000 MED EXP (Any one person) \$ PERSONAL & ADV INJURY \$ 1,000,000 GENERAL AGGREGATE \$ 2,000,000 PRODUCTS - COMP/OP AGG \$ 2,000,000 \$
B	AUTOMOBILE LIABILITY <input checked="" type="checkbox"/> ANY AUTO <input type="checkbox"/> ALL OWNED AUTOS <input type="checkbox"/> SCHEDULED AUTOS <input checked="" type="checkbox"/> HIRED AUTOS <input checked="" type="checkbox"/> NON-OWNED AUTOS	Y	Y	SI8CA00141-221	1/14/2022	1/14/2023	COMBINED SINGLE LIMIT (Ea accident) \$ 1,000,000 BODILY INJURY (Per person) \$ BODILY INJURY (Per accident) \$ PROPERTY DAMAGE (Per accident) \$ \$
C	UMBRELLA LIAB <input checked="" type="checkbox"/> OCCUR <input checked="" type="checkbox"/> EXCESS LIAB <input type="checkbox"/> CLAIMS-MADE DED RETENTION \$	Y	Y	UXP1035252-02	1/14/2022	1/14/2023	EACH OCCURRENCE \$ 4,000,000 AGGREGATE \$ 4,000,000 \$
	WORKERS COMPENSATION AND EMPLOYERS' LIABILITY ANY PROPRIETOR/PARTNER/EXECUTIVE OFFICER/MEMBER EXCLUDED? (Mandatory in NH) <input type="checkbox"/> Y/N If yes, describe under DESCRIPTION OF OPERATIONS below		N/A				<input type="checkbox"/> WC STATUTORY LIMITS <input type="checkbox"/> OTHER E.L. EACH ACCIDENT \$ E.L. DISEASE - EA EMPLOYEE \$ E.L. DISEASE - POLICY LIMIT \$
A	Excess Liability #2	Y	Y	SI8EX01314-221	1/14/2022	1/14/2023	Each Occ/ Aggregate \$5,000,000 Total Limits \$10,000,000

DESCRIPTION OF OPERATIONS / LOCATIONS / VEHICLES (Attach ACORD 101, Additional Remarks Schedule, if more space is required)

Additional Insured extension of coverage is provided by above referenced General Liability policy where required by written agreement.
 Avon Property Owners Association, Inc. Fireworks Display Date: July 4, 2022 Rain Date: July 5, 2022
 Avon Property Owners Association, Inc. Fireworks Display Location: Avon Fishing Pier, 41001 NC 12, Avon, NC 27915
 Additional Insured: Cape Hatteras National Seashore

CERTIFICATE HOLDER**CANCELLATION**

Cape Hatteras National Seashore
 1401 National Park Drive
 Manteo NC 27954

SHOULD ANY OF THE ABOVE DESCRIBED POLICIES BE CANCELLED BEFORE THE EXPIRATION DATE THEREOF, NOTICE WILL BE DELIVERED IN ACCORDANCE WITH THE POLICY PROVISIONS.

AUTHORIZED REPRESENTATIVE

© 1988-2010 ACORD CORPORATION. All rights reserved.



CERTIFICATE OF LIABILITY INSURANCE

DATE (MM/DD/YYYY)
02/14/2022

THIS CERTIFICATE IS ISSUED AS A MATTER OF INFORMATION ONLY AND CONFERS NO RIGHTS UPON THE CERTIFICATE HOLDER. THIS CERTIFICATE DOES NOT AFFIRMATIVELY OR NEGATIVELY AMEND, EXTEND OR ALTER THE COVERAGE AFFORDED BY THE POLICIES BELOW. THIS CERTIFICATE OF INSURANCE DOES NOT CONSTITUTE A CONTRACT BETWEEN THE ISSUING INSURER(S), AUTHORIZED REPRESENTATIVE OR PRODUCER, AND THE CERTIFICATE HOLDER.

IMPORTANT: If the certificate holder is an ADDITIONAL INSURED, the policy(ies) must be endorsed. If SUBROGATION IS WAIVED, subject to the terms and conditions of the policy, certain policies may require an endorsement. A statement on this certificate does not confer rights to the certificate holder in lieu of such endorsement(s).

PRODUCER Applied Risk Services, Inc. 10825 Old Mill Rd Omaha, NE 68154 (877)234-4420	CONTACT NAME: PHONE (A/C, No, Ext): (877)234-4420 FAX (A/C, No): (877)234-4421	
	E-MAIL ADDRESS: PRODUCER CUSTOMER ID #	
INSURED Pyrotecnico 299 Wilson Rd New Castle, PA 16101 CTL 1273 1689304	INSURER(S) AFFORDING COVERAGE NAIC #	
	INSURER A: Continental Indemnity Co. 28258	
	INSURER B:	
	INSURER C:	
	INSURER D:	
	INSURER E: INSURER F:	

COVERAGES**CERTIFICATE NUMBER:****REVISION NUMBER:**

THIS IS TO CERTIFY THAT THE POLICIES OF INSURANCE LISTED BELOW HAVE BEEN ISSUED TO THE INSURED NAMED ABOVE FOR THE POLICY PERIOD INDICATED. NOTWITHSTANDING ANY REQUIREMENT, TERM OR CONDITION OF ANY CONTRACT OR OTHER DOCUMENT WITH RESPECT TO WHICH THIS CERTIFICATE MAY BE ISSUED OR MAY PERTAIN, THE INSURANCE AFFORDED BY THE POLICIES DESCRIBED HEREIN IS SUBJECT TO ALL THE TERMS, EXCLUSIONS AND CONDITIONS OF SUCH POLICIES. LIMITS SHOWN MAY HAVE BEEN REDUCED BY PAID CLAIMS.

INSR LTR	TYPE OF INSURANCE	ADDL INSR	SUBR WVD	POLICY NUMBER	POLICY EFF (MM/DD/YYYY)	POLICY EXP (MM/DD/YYYY)	LIMITS	
	GENERAL LIABILITY						EACH OCCURRENCE	\$
	<input type="checkbox"/> COMMERCIAL GENERAL LIABILITY	<input type="checkbox"/>	<input type="checkbox"/>				DAMAGE TO RENTED PREMISES (Ea occurrence)	\$
	<input type="checkbox"/> CLAIMS MADE <input type="checkbox"/> OCCUR						MED EXP (any one person)	\$
							PERSONAL & ADV INJURY	\$
	GEN'L AGGREGATE LIMIT APPLIES PER:						GENERAL AGGREGATE	\$
	<input type="checkbox"/> POLICY <input type="checkbox"/> PRO-JECT <input type="checkbox"/> LOC						PRODUCTS - COMP/OP AGG	\$
								\$
	AUTOMOBILE LIABILITY						COMBINED SINGLE LIMIT (Ea accident)	\$
	<input type="checkbox"/> ANY AUTO	<input type="checkbox"/>	<input type="checkbox"/>				BODILY INJURY (Per person)	\$
	<input type="checkbox"/> ALL OWNED AUTOS						BODILY INJURY (Per accident)	\$
	<input type="checkbox"/> SCHEDULED AUTOS						PROPERTY DAMAGE (Per accident)	\$
	<input type="checkbox"/> HIRED AUTOS							\$
	<input type="checkbox"/> NON-OWNED AUTOS							\$
								\$
	UMBRELLA LIAB <input type="checkbox"/> OCCUR						EACH OCCURRENCE	\$
	EXCESS LIAB <input type="checkbox"/> CLAIMS MADE	<input type="checkbox"/>	<input type="checkbox"/>				AGGREGATE	\$
	<input type="checkbox"/> DEDUCTIBLE							\$
	<input type="checkbox"/> RETENTION \$							\$
A	WORKERS COMPENSATION AND EMPLOYERS' LIABILITY						<input checked="" type="checkbox"/> WC STATU-TORY LIMITS	OTH-ER
	ANY PROPRIETOR/PARTNER/EXECUTIVE OFFICER/MEMBER EXCLUDED? (Mandatory in NH) If yes, describe under SPECIAL PROVISIONS below	Y/N N	N/A	82-872096-04-24	06/07/2021	06/07/2022	E.L. EACH ACCIDENT	\$ 1,000,000
							E.L. DISEASE - EA EMPLOYEE	\$ 1,000,000
							E.L. DISEASE - POLICY LIMIT	\$ 1,000,000

DESCRIPTION OF OPERATIONS / LOCATIONS / VEHICLES (Attach Acord 101, Additional Remarks Schedule, if more space is required)

CERTIFICATE HOLDER**CANCELLATION**Cape Hatteras National Seashore
1401 National Park Drive
Manteo, NC 27954

SHOULD ANY OF THE ABOVE DESCRIBED POLICIES BE CANCELLED BEFORE THE EXPIRATION DATE THEREOF, NOTICE WILL BE DELIVERED IN ACCORDANCE WITH THE POLICY PROVISIONS.

AUTHORIZED REPRESENTATIVE

1000002116

In accordance with the provisions of Title XI, Organized Crime Control Act of 1970, and the regulations issued thereunder (27 CFR Part 555), you may engage in the activity specified in this license or permit within the limitations of Chapter 40, Title 18, United States Code and the regulations issued thereunder, until the expiration date shown. **THIS LICENSE IS NOT TRANSFERABLE UNDER 27 CFR 555.53.** See "WARNINGS" and "NOTICES" on reverse.

Direct ATF Correspondence To	ATF - Chief, FELC 244 Needy Road Martinsburg, WV 25405-9431	License/Permit Number	8-PA-073-23-4J-12122
---------------------------------	---	--------------------------	-----------------------------

Chief, Federal Explosives Licensing Center (FELC) <i>Mama Howard</i>	Expiration Date	September 1, 2024
---	--------------------	--------------------------

Name
PYROTECNICO

Premises Address (Changes? Notify the FELC at least 10 days before the move.)
**299 WILSON RD
NEW CASTLE, PA 16101-**

Type of License or Permit
23-IMPORTER OF EXPLOSIVES

Purchasing Certification Statement
The licensee or permittee named above shall use a copy of this license or permit to assist a transferor of explosives to verify the identity and the licensed status of the licensee or permittee as provided by 27 CFR Part 555. The signature on each copy must be an original signature. A faxed, scanned or e-mailed copy of the license or permit with a signature intended to be an original signature is acceptable. The signature must be that of the Federal Explosives Licensee (FEL) or a responsible person of the FEL. I certify that this is a true copy of a license or permit issued to the licensee or permittee named above to engage in the business or operations specified above under "Type of License or Permit."

Mailing Address (Changes? Notify the FELC of any changes.)
PYROTECNICO FIREWORKS INC
PYROTECNICO
PO BOX 149
NEW CASTLE, PA 16103-0149

Licensee/Permittee Responsible Person Signature
STEPHEN VITALE
Printed Name
Date
Nov. 29, 2021
President/CEO
Position Title

ATF Form 5400.14/5400.15 Part I
Revised September 2011

Previous Edition is Obsolete PYROTECNICO FIREWORKS INC:299 WILSON RD:16101:8-PA-073-23-4J-12122:September 1, 2024:23-IMPORTER OF EXPLOSIVES

Federal Explosives License (FEL) Customer Service Information

Federal Explosives Licensing Center (FELC) 244 Needy Road Martinsburg, WV 25405-9431	Toll-free Telephone Number: (877) 283-3352 Fax Number: (304) 616-4401 E-mail: FELC@atf.gov	ATF Homepage: www.atf.gov
--	--	---------------------------

Change of Address (27 CFR 555.54(a)(1)). Licensees or permittees may during the term of their current license or permit remove their business or operations to a new location at which they intend regularly to carry on such business or operations. The licensee or permittee is required to give notification of the new location of the business or operations not less than 10 days prior to such removal with the Chief, Federal Explosives Licensing Center. The license or permit will be valid for the remainder of the term of the original license or permit. **(The Chief, FELC, shall, if the licensee or permittee is not qualified, refer the request for amended license or permit to the Director of Industry Operations for denial in accordance with § 555.54.)**

Right of Succession (27 CFR 555.59). (a) Certain persons other than the licensee or permittee may secure the right to carry on the same explosive materials business or operations at the same address shown on, and for the remainder of the term of, a current license or permit. Such persons are: (1) The surviving spouse or child, or executor, administrator, or other legal representative of a deceased licensee or permittee; and (2) A receiver or trustee in bankruptcy, or an assignee for benefit of creditors. (b) In order to secure the right provided by this section, the person or persons continuing the business or operations shall furnish the license or permit for for that business or operations for endorsement of such succession to the Chief, FELC, within 30 days from the date on which the successor begins to carry on the business or operations.

(Continued on reverse side)

Cut Here ✂

Federal Explosives License/Permit (FEL) Information Card

License/Permit Name: **PYROTECNICO FIREWORKS INC**

Business Name: **PYROTECNICO**

License/Permit Number: **8-PA-073-23-4J-12122**

License/Permit Type: **23-IMPORTER OF EXPLOSIVES**

Expiration: **September 1, 2024**

Please Note: Not Valid for the Sale or Other Disposition of Explosives.

WARNINGS

1. As provided in Title XI of the Organized Crime Control Act of 1970 (U.S.C. § 842(i)), it is unlawful for any person who (1) is under indictment for, or has been convicted in any court of, a crime punishable by imprisonment for a term exceeding 1 year, (2) is a fugitive from justice, (3) is an unlawful user of, or addicted to any controlled substance (as defined in section 102 of the Controlled Substances Act (21 U.S.C. 802)), (4) has been adjudicated as a mental defective or has been committed to a mental institution, to ship, transport, or receive any explosive materials in interstate or foreign commerce, (5) is an alien, other than an alien who is lawfully admitted for permanent residence (as that term is defined in section 101(a)(20) of the Immigration and Naturalization Act), or meets any other exception under section 842(i)(5), (6) has been discharged from the armed forces under dishonorable conditions, or (7) having been a citizen of the United States, has renounced the citizenship of that person.
2. **Federal Regulation 27 CFR 555.53 - Licensees and permits issued under this part are not transferable to another person. In the event of the lease, sale, or other transfer of the business or operations covered by the license or permit, the successor must obtain the license or permit required by this part before commencing business or operations.**
3. **Alteration or Changes to the License or Permit. Alterations or changes in the original license or permit or in duplications thereof violates 18 U.S.C. 1001, an offense punishable by imprisonment for not more than 5 years and/or a fine of not more than \$250,000.**

NOTICES

1. Any change in trade name or control of this business or operations **MUST** be reported within 30 days of the change to the Chief, Federal Explosives Licensing Center (FELC), 244 Needy Road, Martinsburg, WV 25405-9431. (27 CFR 555.56-555.57). A licensee or permittee who reports a Change of Control must, upon expiration of the license or permit, file an ATF Form 5400.13/5400.16.
2. Under § 555.46, Renewal of License/Permit, if a licensee or permittee intends to continue the business or operations described on a license or permit issued under this part during any portion of the ensuing year, the licensee or permittee shall, unless otherwise notified in writing by the Chief, FELC, execute and file with ATF prior to the expiration of the license or permit an application for a license or permit renewal, ATF Form 5400.14/5400.15 Part III, in accordance with the instructions on the form, and the required fee. In the event the licensee or permittee does not timely file an ATF Form 5400.14/5400.15 Part III, the licensee or permittee must file an ATF Form 5400.13/5400.16 as required by § 555.45, and obtain the required license or permit before continuing business or operations. A renewal application will automatically be mailed by ATF to the "mailing address" on the license or permit approximately 60 days prior to the expiration date of the license or permit. If the application is not received 30 days prior to the expiration date, the licensee or permittee should contact the FELC.
Note: The user-limited permits are not renewable.
3. This license or permit is conditional upon compliance by you with the Clean Water Act (33 U.S.C. § 1341(a)).
4. **THIS LICENSE OR PERMIT MUST BE POSTED AND KEPT AVAILABLE FOR INSPECTION (27 CFR 555.101).**

ATF Form 5400.14/5400.15 Part I
Revised October 2011

Federal Explosives License (FEL) Customer Service Information
(Continued from front)

Discontinuance of Business (27 CFR 555.61)(27 CFR 555.128). Where an explosives materials business or operations is succeeded by a new licensee or permittee, the records prescribed by this subpart shall appropriately reflect such facts and shall be delivered to the successor, or may be, within 30 days following business discontinuance, delivered to the ATF Out-of-Business Records Center, 244 Needy Road, Martinsburg, WV 25405, or to any ATF office in the division in which the business was located. Where discontinuance of the business is absolute, the records shall be delivered within 30 days following the business discontinuance to the ATF Out-of-Business Records Center, 244 Needy Road, Martinsburg, WV 25405, or to any ATF office in the division in which the business was located.

Explosive materials must be stored in conformance with requirements set forth in 27 CFR, Part 55. It is unlawful for any person to store any explosive materials in a manner not in conformity with these regulations.

**TO REPORT LOST OR STOLEN EXPLOSIVES, YOU MUST IMMEDIATELY NOTIFY ATF:
CALL TOLL FREE - (888) ATF-BOMB**

✂ Cut Here

Federal Explosives Licensing Center (FELC) 244 Needy Road Martinsburg, WV 25405-9431	Toll-free number: (877) 283-3352 Fax number: (304) 616-4401 E-mail: FELC@atf.gov
ATF Hotline Numbers	
Arson Hotline: 1-888-ATF-FIRE (1-888-283-3473)	
Bomb Hotline: 1-888-ATF-BOMB (1-888-283-2662)	
Report Illegal Firearms Activity: 1-800-ATF-GUNS (1-800-283-4867)	
Firearms Theft Hotline: 1-888-930-9275	
Report Stolen, Hijacked or Seized Cigarettes: 1-800-659-6242	
Other Criminal Activity: 1-888-ATF-TIPS (1-888-283-8477)	



**Hyde County (Ocracoke)
Display Date: July 2th 2022**

**Avon Property Owners Association (Avon)
Display Date: July 4th 2022**

Ferry Itinerary

Friday, July 1st, 2022

2:00 pm - Fireworks truck en route to Hatteras-Ocracoke Ferry For Ocracoke fireworks Display.

3:00 pm to 4:00 pm - One box truck containing fireworks, two to three essential crew vehicles and the fire marshal takes the ferry to Ocracoke.

Saturday, July 2nd, 2022

Ocracoke Fireworks Display

Sunday, July 4th, 2022

12:00 am to 1:00 am - One truck fireworks and two to three essential crew vehicles take Ocracoke-Hatteras ferry en route to Hatteras.

Avon Fireworks Display



Standard Operating Procedure / Safety Plan Fireworks Displays

Pyrotecnico Fireworks, Inc.
P.O. Box 149
New Castle, PA 16103
Headquarter Office: 800.854.4705
www.pyrotecnico.com

Pyrotecnico Emergency Contacts:

- Paul Gaffney, Director of Facilities/Safety & Compliance
 - Cell: 610.656.0385 | Email: pgaffney@pyrotecnico.com
- Vic Laurenza, Show Producer
 - Cell: 724.510.6195 | Email: vlaurenza@pyrotecnico.com
- Chem-Tel 24-Hour Emergency Response: 1.800.255.3924

Standard Guidelines:

All safety precautions as prescribed by the National Fire Protection Association (NFPA) code 1123 shall be adhered to at all times.

As required by the Authority Having Jurisdiction (“AHJ”), all inspections of the firing area(s) will be arranged in advance of the crew’s arrival on site.

All mortars and/or racks used in the display shall be made of and/or from approved materials sufficient to provide a safe display per the National Fire Protection Association (NFPA) code 1123.

A safe perimeter of 70 feet per inch, at minimum, of the largest shell size (National Fire Protection Association (“NFPA”) Guidelines, Section 1123) shall be maintained and secured at all times by the Sponsor and Pyrotecnico.

The fireworks and firing equipment shall not be left unattended at any time while on the display site and shall be protected from inclement weather at all times.



All Pyrotecnico personnel shall wear protective safety equipment for head, eye, hearing and feet as well as long sleeves and pants during the set-up, firing and clean up of the fireworks. Shorts are unacceptable attire.

Neither smoking nor smoking materials such as matches, lighters or open flame shall be within 50 feet of fireworks or pyrotechnic materials.

The use of cell phones and/or radios that generate radio frequencies will be kept to a minimum within the immediate discharge area while pyrotechnics are being prepared, loaded, set-up and firing.

Security on site will be arranged by the event Sponsor if needed.

Only assigned technicians required to set-up and perform the display will be allowed on the display site.

No person shall be allowed on site that is under the influence of alcohol, narcotics or medication which could adversely affect their ability to safely perform their duties.

Arrangements should be made by the event Sponsor for fire service and emergency medical services ("EMS") to be available during the fireworks display(s).

Pyrotecnico will have a minimum of two (2) water pressure fire extinguishers on site during the fireworks display.

Pyrotecnico provides appropriate insurance with limits of \$10M.

Fireworks Display Termination Procedure:

Weather conditions will be assessed by the fire official and the lead fireworks operator on the display site according to the conditions on site at the time. Bad weather, including but is not limited to, is defined as winds in excess of 15 mph or wind gusts of 20 mph or more, along with rain and/or thunderstorms. Other non-weather related emergencies can also terminate firing which shall also be determined by the fire official and the lead fireworks exhibitor at the display site.

Crowd control is imperative and must be maintained by security personnel, monitors and barriers. If at any time during the load in, firing and strike, security patrols and/or monitors detect any breach of the fall out/safety zone perimeter, any and all activity will cease immediately. Activity will only resume when the security of the fall out zone has been reestablished.



Arrival On-Site

The operator shall contact the sponsor, sponsor's on-site contact and the AHJ to confirm the following: their arrival, the display time, the method of communication to indicate when the firing should start, the length of the display, the wind direction, safety distances, cool down period, potential overhead obstructions and the first light search plan.

All AHJ requirements received shall be followed.

The operator will conduct a Pyrotecnico crew meeting to discuss all safety requirements, details of the display and assign tasks.

Pre-Display

The lead operator shall verify the following:

An inspection of all equipment and materials has been completed prior to set up.

The safety/fall out zone is clear of all unauthorized personnel.

Fire extinguishers are placed at strategic locations.

All mortars racks are perpendicular to audience. Racks and pyrotechnic holders are free of debris, and secured and stable to prevent falling over during use.

All fireworks display shells are pre-loaded and properly fit into mortars.

All mortar racks and finale chains are covered with foil.

For a manual firing, extra fuses are readily available.

For electrical firing, the arming key has been removed from the board and in the lead operator's physical possession at all times during load-in. The lead operator will also confirm prior to testing and the display that the firing system battery is fully charged; the igniter wires are secured and cleared of adjacent mortars; the firing modules are secured and protected; and all cables (and ground wires, if applicable) are connected from the firing modules to the firing board.

For continuity testing of an electrical firing, in addition to confirming the firing board is in "TEST" mode prior to the test, the lead operator shall confirm that the safety fall out radius is clear of



unauthorized and non-essential personnel, everyone is informed of the testing is commencing and the board is disarmed & arming key is REMOVED after testing. Continuity testing shall continue until 100% continuity is confirmed. The final continuity check shall occur not more than 30 to 45 minutes prior to the display start time.

Immediately before the display, the lead operator shall confirm the crowd has been controlled and the safety/fall out zone is maintained; all applicable personnel, including fire service, EMS units and Pyrotecnico crew members, are available and ready; and that the current and approaching weather is favorable.

Post Display:

Fifteen minutes after the conclusion of the display, a search will be conducted by Pyrotecnico personnel of the display and fallout areas to confirm that any unfired live product or shells are accounted for, properly handled, repackaged and secured according to federal DOT regulations.

Non-fired product shall not be shot without the permission of BOTH the sponsor and the fire department.

Once the all clear sign is given disassembly of the display shall begin.

The firing site shall be cleaned.

A mandatory first daylight search shall be conducted the following day to inspect the firing site, fall-out areas, spectator viewing areas and any reasonable surrounding areas for pyrotechnic debris and "duds". All pyrotechnic debris and "duds" shall be accounted for, properly handled, repackaged and secured according to federal DOT regulations.

Safety Data Sheet

acc. to OSHA HCS (29 CFR 1910.1200)

Printing date: 01/06/2017

Revision: 01/06/2017

1 Identification

· **Product identifier:** Fireworks, Division 1.3 Explosive

· **Trade name:**

Fireworks, Display

· **Product code:**

Fireworks, 1.3G UN0335

· **Recommended use and restriction on use**

· **Recommended use:** Explosive product for professional use for entertainment and technical purposes

· **Restrictions on use:** Contact manufacturer/supplier

· **Details of the supplier of the Safety Data Sheet**

· **Manufacturer/Supplier:**

Pyrotecnico Fireworks Inc.
299 Wilson Rd
New Castle, PA 16101
724-652-9555

· **Emergency telephone number:**

ChemTel Inc.
(800)255-3924, +1 (813)248-0585

2 Hazard(s) identification

· **Classification of the substance or mixture**

Expl. 1.3 H203 Explosive; fire, blast or projection hazard.

· **Label elements**

· **GHS label elements**

The product is classified and labeled according to the Globally Harmonized System (GHS).

· **Hazard pictograms:**



GHS01

· **Signal word:** Danger

· **Hazard statements:**

H203 Explosive; fire, blast or projection hazard.

· **Precautionary statements:**

P210 Keep away from heat/sparks/open flames/hot surfaces. No smoking.

P250 Do not subject to grinding/shock/friction.

P280 Wear protective gloves/protective clothing/eye protection/face protection.

P373 DO NOT fight fire when fire reaches explosives.

P370+P380 In case of fire: Evacuate area.

P372 Explosion risk in case of fire.

(Cont'd. on page 2)

Safety Data Sheet

acc. to OSHA HCS (29 CFR 1910.1200)

Printing date: 01/06/2017

Revision: 01/06/2017

Trade name:

Fireworks, Display

(Cont'd. of page 1)

P401 Store in accordance with local/regional/national/international regulations.

P501 Dispose of contents/container in accordance with local/regional/national/international regulations.

· **Other hazards** There are no other hazards not otherwise classified that have been identified.

· **Explosive Product Notice**

PREVENTION OF ACCIDENTS IN THE USE OF EXPLOSIVES - The prevention of accidents in the use of explosives is a result of careful planning and observance of the best known practices. The explosives user must remember that he is dealing with a powerful force and that various devices and methods have been developed to assist him in directing this force. He should realize that this force, if misdirected, may either kill or injure both him and his fellow workers.

WARNING - All explosives are dangerous and must be carefully handled and used following approved safety procedures either by or under the direction of competent, experienced persons in accordance with all applicable federal, state, and local laws, regulations, or ordinances. If you have any questions or doubts as to how to use any explosive product, DO NOT USE IT before consulting with your supervisor, or the manufacturer, if you do not have a supervisor. If your supervisor has any questions or doubts, he should consult the manufacturer before use.

3 Composition/information on ingredients

· **Chemical characterization: Mixtures**

· **Components:**

Components for product possessing only physical hazards do not require reporting. These components are considered proprietary.

4 First-aid measures

· **Description of first aid measures**

· **General information:**

Information is only applicable to product contents, and not to product as normally supplied. This information is applicable to damaged, leaking, or spilled product as contact with contents is possible under these conditions.

· **After inhalation:** Supply fresh air; consult doctor in case of complaints.

· **After skin contact:**

Wash with soap and water.

In case of minor burns, flush with cool water.

If skin irritation is experienced, consult a doctor.

· **After eye contact:**

Remove contact lenses if worn.

Rinse opened eye for several minutes under running water. If symptoms persist, consult a doctor.

· **After swallowing:**

Unlikely route of exposure.

Do not induce vomiting; immediately call for medical help.

(Cont'd. on page 3)

Safety Data Sheet

acc. to OSHA HCS (29 CFR 1910.1200)

Printing date: 01/06/2017

Revision: 01/06/2017

Trade name:

Fireworks, Display

(Cont'd. of page 2)

- **Most important symptoms and effects, both acute and delayed:**
Blast injury if mishandled.
Thermal burns, if mishandled.
- **Danger:** Danger of blast or crush-type injuries.
- **Indication of any immediate medical attention and special treatment needed:**
Product may produce physical injury if mishandled. Treatment of these injuries should be based on the clinical presentation.

5 Fire-fighting measures

- **Extinguishing media**
- **Suitable extinguishing agents:**
DO NOT fight fire when fire reaches explosives.
Flood area with water. If no water is available, carbon dioxide, dry chemical or earth may be used. If the fire reaches the cargo, withdraw and let fire burn.
- **For safety reasons unsuitable extinguishing agents:** None.
- **Special hazards arising from the substance or mixture**
Explosive; fire, blast or projection hazard.
During heating or in case of fire poisonous gases are produced.
- **Advice for firefighters**
- **Protective equipment:**
Wear self-contained respiratory protective device.
Wear fully protective suit.
- **Additional information:**
Eliminate all ignition sources if safe to do so.
In case of fire: Evacuate area. Fight fire remotely due to the risk of explosion.
Cool endangered receptacles with water spray.
Flammability Classification: (defined by 29 CFR 1910.1200) Explosive. Can explode under fire conditions. Individual devices will randomly explode. Mass explosion of multiple devices is possible under certain conditions. Burning material may produce toxic and irritating vapors. In unusual cases, shrapnel may be thrown from exploding devices under containment. See 2012 Emergency response Guidebook for further information.

6 Accidental release measures

- **Personal precautions, protective equipment and emergency procedures**
Wear protective equipment. Keep unprotected persons away.
Remove persons from danger area.
Ensure adequate ventilation.
Isolate area and prevent access.
- **Environmental precautions**
Do not allow undiluted product or large quantities of it to reach ground water, water course or sewage system.
- **Methods and material for containment and cleaning up**
Pick up mechanically.

(Cont'd. on page 4)

Safety Data Sheet

acc. to OSHA HCS (29 CFR 1910.1200)

Printing date: 01/06/2017

Revision: 01/06/2017

Trade name:

Fireworks, Display

(Cont'd. of page 3)

Send for recovery or disposal in suitable receptacles.

· **Reference to other sections**

See Section 7 for information on safe handling.

See Section 8 for information on personal protection equipment.

See Section 13 for disposal information.

7 Handling and storage

· **Handling**· **Precautions for safe handling:**

Handle with care. Avoid jolting, friction and impact.

Restrict the quantity stored at the work place.

Keep out of reach of children.

· **Information about protection against explosions and fires:**

In case of fire: Evacuate area.

Explosion risk in case of fire.

Keep away from sparks and open flames. - No smoking.

Emergency cooling must be available in case of nearby fire.

· **Conditions for safe storage, including any incompatibilities**· **Storage**· **Requirements to be met by storerooms and receptacles:**

Avoid storage near extreme heat, ignition sources or open flame.

· **Information about storage in one common storage facility:**

Store in accordance with local/regional/national/international regulations.

Store away from foodstuffs.

Store away from flammable substances.

· **Further information about storage conditions:**

Store in cool, dry conditions in well sealed receptacles.

Store locked up.

· **Specific end use(s)** No relevant information available.

8 Exposure controls/personal protection

· **Control parameters**· **Components with limit values that require monitoring at the workplace:**

The product does not contain any relevant quantities of materials with critical values that have to be monitored at the workplace.

· **Exposure controls**· **Personal protective equipment:**· **General protective and hygienic measures:**

The usual precautionary measures for handling chemicals should be followed.

Keep away from foodstuffs, beverages and feed.

Wash hands before breaks and at the end of work.

· **Engineering controls:** Provide adequate ventilation.

(Cont'd. on page 5)

Safety Data Sheet

acc. to OSHA HCS (29 CFR 1910.1200)

Printing date: 01/06/2017

Revision: 01/06/2017

Trade name:

Fireworks, Display

(Cont'd. of page 4)

- **Breathing equipment:** Not required under normal conditions of use.
- **Protection of hands:** When needed, wear gloves for protection against mechanical hazards.
- **Eye protection:**



Safety glasses

Follow relevant national guidelines concerning the use of protective eyewear.

- **Body protection:** When needed, wear protective clothing for protection against mechanical hazards.
- **Limitation and supervision of exposure into the environment**
No relevant information available.
- **Risk management measures**
Organizational measures should be in place for all activities involving this product.

9 Physical and chemical properties

Information on basic physical and chemical properties

- **Appearance:**
 - **Form:** Outer shell containing powder, granular, or solid materials.
 - **Color:** According to product specification
- **Odor:** Odorless
- **Odor threshold:** Not determined.
- **pH-value:** Not applicable.
- **Melting point/Melting range:** Not determined.
- **Boiling point/Boiling range:** Not determined.
- **Flash point:** Not applicable.
- **Flammability (solid, gaseous):** Fire or projection hazard.
- **Auto-ignition temperature:** Not determined.
- **Decomposition temperature:** Not determined.
- **Danger of explosion:** Heating may cause an explosion.
- **Explosion limits**
 - **Lower:** Not determined.
 - **Upper:** Not determined.
- **Vapor pressure:** Not applicable.
- **Density:** Not determined.
- **Relative density:** Not determined.
- **Vapor density:** Not applicable.
- **Evaporation rate:** Not applicable.

(Cont'd. on page 6)

Safety Data Sheet

acc. to OSHA HCS (29 CFR 1910.1200)

Printing date: 01/06/2017

Revision: 01/06/2017

Trade name:

Fireworks, Display

(Cont'd. of page 5)

- | | |
|---|------------------------------------|
| · Solubility in / Miscibility with Water: | Insoluble. |
| · Partition coefficient (n-octanol/water): | Not determined. |
| · Viscosity | |
| Dynamic: | Not applicable. |
| Kinematic: | Not applicable. |
| · Other information | No relevant information available. |

10 Stability and reactivity

- **Reactivity:** No relevant information available.
- **Chemical stability:**
- **Thermal decomposition / conditions to be avoided:** Risk of explosion if heated under confinement.
- **Possibility of hazardous reactions**
Explosive; fire, blast or projection hazard.
Toxic fumes may be released if heated above the decomposition point.
Reacts with strong acids and alkali.
- **Conditions to avoid**
Excessive heat.
Sources of ignition: sparks, open flame, incompatible materials
- **Incompatible materials** Oxidizers, strong bases, strong acids
- **Hazardous decomposition products**
Carbon monoxide and carbon dioxide
Nitrogen oxides
Sulfur oxides (SO_x)

11 Toxicological information

- **Information on toxicological effects**
- **Acute toxicity:**
- **LD/LC50 values that are relevant for classification:** None.
- **Primary irritant effect:**
- **On the skin:**
Not a skin irritant in unused form. Vapors/particles from used product are possibly irritating to skin.
- **On the eye:**
Not an eye irritant in unused form. Vapors/particles from used product are possibly irritating to eyes.
- **Sensitization:** Based on available data, the classification criteria are not met.
- **Carcinogenic categories**

· IARC (International Agency for Research on Cancer):
--

None of the ingredients are listed.

(Cont'd. on page 7)

Safety Data Sheet

acc. to OSHA HCS (29 CFR 1910.1200)

Printing date: 01/06/2017

Revision: 01/06/2017

Trade name:

Fireworks, Display

(Cont'd. of page 6)

· **NTP (National Toxicology Program):**

None of the ingredients are listed.

· **OSHA-Ca (Occupational Safety & Health Administration):**

None of the ingredients are listed.

· **Probable route(s) of exposure:**

Skin contact.

Eye contact.

Inhalation.

· **Acute effects (acute toxicity, irritation and corrosivity):**

Danger of blast or crush-type injuries.

Risk of thermal burns.

· **Repeated dose toxicity:** From product as supplied: None.· **CMR effects (carcinogenicity, mutagenicity and toxicity for reproduction)**· **Germ cell mutagenicity:** Based on available data, the classification criteria are not met.· **Carcinogenicity:** Based on available data, the classification criteria are not met.· **Reproductive toxicity:** Based on available data, the classification criteria are not met.· **STOT-single exposure:** Based on available data, the classification criteria are not met.· **STOT-repeated exposure:** Based on available data, the classification criteria are not met.· **Aspiration hazard:** Based on available data, the classification criteria are not met.

12 Ecological information

· **Toxicity**· **Aquatic toxicity** No relevant information available.· **Persistence and degradability** No relevant information available.· **Bioaccumulative potential:** May be accumulated in organism· **Mobility in soil:** No relevant information available.· **Other adverse effects** No relevant information available.

13 Disposal considerations

· **Waste treatment methods**· **Recommendation:**

Must not be disposed of together with household garbage. Do not allow product to reach sewage system. Incinerate in accordance with local, state and federal regulations.

The user of this material has the responsibility to dispose of unused material, residues and containers in compliance with all relevant local, state and federal laws and regulations regarding treatment, storage and disposal for hazardous and nonhazardous wastes. Residual materials should be treated as hazardous.

(Cont'd. on page 8)

Safety Data Sheet

acc. to OSHA HCS (29 CFR 1910.1200)

Printing date: 01/06/2017

Revision: 01/06/2017

Trade name:

Fireworks, Display

(Cont'd. of page 7)

- **Uncleaned packagings**
- **Recommendation:** Disposal must be made according to official regulations.

14 Transport information

· **UN-Number**
 · DOT, ADR, IMDG UN0335
 · IATA FORBIDDEN

· **UN proper shipping name**
 · DOT, ADR, IMDG Fireworks
 · IATA FORBIDDEN

· **Transport hazard class(es)**

· DOT



· Class 1.3
 · Label 1.3G

· ADR



· Class 1.3
 · Label 1.3G

· IMDG



· Class 1.1
 · Label 1.3G

· IATA
 · Class FORBIDDEN

· **Packing group**
 · DOT II

· **Environmental hazards**
 · **Marine pollutant:** No

· **Special precautions for user** Not applicable.

(Cont'd. on page 9)

Safety Data Sheet

acc. to OSHA HCS (29 CFR 1910.1200)

Printing date: 01/06/2017

Revision: 01/06/2017

Trade name:

Fireworks, Display

(Cont'd. of page 8)

· **EMS Number:** F-S,B-X· **Transport in bulk according to Annex II of
MARPOL73/78 and the IBC Code** Not applicable.**15 Regulatory information**

- **Safety, health and environmental regulations/legislation specific for the substance or mixture**
- **United States (USA)**
- **SARA**

· **Section 302 (extremely hazardous substances):**

None of the ingredients are listed.

· **Section 304 (emergency release notification):**

None of the ingredients are listed.

· **Section 355 (extremely hazardous substances):**

None of the ingredients are listed.

· **Section 313 (Specific toxic chemical listings):**

Contact manufacturer.

· **TSCA (Toxic Substances Control Act)**

All ingredients are listed.

· **Proposition 65 (California)**· **Chemicals known to cause cancer:**

Contact manufacturer.

· **Chemicals known to cause reproductive toxicity for females:**

Contact manufacturer.

· **Chemicals known to cause reproductive toxicity for males:**

Contact manufacturer.

· **Chemicals known to cause developmental toxicity:**

Contact manufacturer.

· **Carcinogenic categories**· **EPA (Environmental Protection Agency):**

None of the ingredients are listed.

· **IARC (International Agency for Research on Cancer):**

Contact manufacturer.

(Cont'd. on page 10)

Safety Data Sheet

acc. to OSHA HCS (29 CFR 1910.1200)

Printing date: 01/06/2017

Revision: 01/06/2017

Trade name:

Fireworks, Display

(Cont'd. of page 9)

· **NIOSH-Ca (National Institute for Occupational Safety and Health):**

Contact manufacturer.

16 Other information

This information is based on our present knowledge. However, this shall not constitute a guarantee for any specific product features and shall not establish a legally valid contractual relationship.

· **Date of preparation / last revision** 01/06/2017 / -· **Abbreviations and acronyms:**

ADR: European Agreement concerning the International Carriage of Dangerous Goods by Road

IMDG: International Maritime Code for Dangerous Goods

DOT: US Department of Transportation

IATA: International Air Transport Association

CAS: Chemical Abstracts Service (division of the American Chemical Society)

LC50: Lethal concentration, 50 percent

LD50: Lethal dose, 50 percent

NIOSH: National Institute for Occupational Safety

OSHA: Occupational Safety & Health

TLV: Threshold Limit Value

PEL: Permissible Exposure Limit

REL: Recommended Exposure Limit

LDLo: Lowest Lethal Dose Observed

Expl. 1.3: Explosives – Division 1.3

· **Sources**Website, European Chemicals Agency (echa.europa.eu)Website, US EPA Substance Registry Services (ofmpub.epa.gov/sorinternet/registry/substreg/home/overview/home.do)Website, Chemical Abstracts Registry, American Chemical Society (www.cas.org)

Patty's Industrial Hygiene, 6th ed., Rose, Vernon, ed. ISBN: 978-0-470-07488-6

Casarett and Doull's Toxicology: The Basic Science of Poisons, 8th Ed., Klaasen, Curtis D., ed., ISBN: 978-0-07-176923-5.

Safety Data Sheets, Individual Manufacturers

SDS Prepared by:

ChemTel Inc.

1305 North Florida Avenue

Tampa, Florida USA 33602-2902

Toll Free North America 1-888-255-3924 Intl. +01 813-248-0573

Website: www.chemtelinc.com



Board Appointments

Description

The following Boards have appointments this month:

1. Virginia S. Tillett Community Center Advisory Board
2. Wanchese Community Center Advisory Board
3. Dare Library Board
4. Fessenden Center Advisory Board
5. Game and Wildlife Commission

Board Action Requested

Take Appropriate Action

Item Presenter

Robert Outten, County Manager



Virginia S. Tillett Community Center Advisory Board

Description

See Attached Summary

Board Action Requested

Take Appropriate Action

Item Presenter

Robert Outten, County Manager

June, 2022

VIRGINIA S. TILLET COMMUNITY CENTER ADVISORY BOARD

(Staggered/Three Year Term)

**The Virginia S. Tillett Community Center Advisory Board nominating committee
Recommends the reappointment of
Lynda Hester, Cindy Perry, Reha Otte and Sara L. Hester Smith for another term.**

Other Members: See attached list

VIRGINIA S. TILLET COMMUNITY CENTER ADVISORY BOARD

Nominating Committee Recommendations

May 10, 2022

Flossie Tugwell and Reha Otte representing the Nominating Committee to the Advisory Board of the Virginia S. Tillett Community Center would like to make the following recommendation:

Lynda Hester, Cindy Perry, Reha Otte and Sara Hester Smith be reappointed to serve a three year term.

Reha Otte

Reha serves several positions within the Virginia S. Tillett Community Center Advisory Board. She serves as the Vice Chairman of the Board in Chairperson's absence, Co Chair of the Nominating Committee, member of the State Certification Planning Committee and is the Co-Coordinator of the Center's Aging Well Services Program. Reha is active in the yearly Toy Drive, wrapping Christmas gifts and participates in one of three evening Christmas events. She enjoys volunteering her time in the 5K races sponsored by the Center.

She has a long and impressive history of volunteer work with the Outer Banks Community serving a term as Lions Club President. Her volunteer work expands to Chairing the Evangelism and Prayer Blanket Ministries within Mt. Olivet United Methodist Church. Here she serves as Meal Co-Coordinator for those needing help during difficult times or having surgery with no immediate caregivers.

Sara Hester Smith

Sara Hester-Smith chairs the Renate Memorial Gardens and has volunteered her time working on the current design and construction of the gardens at the Virginia S. Tillett Community Center. Sara organized community volunteers to come out and construct the gardens as a team effort. The gardens have raised beds to make it accessible to all including wheelchair access.

Renate Macchirole was an employee at the Virginia Tillett Community Center and worked as the Nutrition Site Co-Coordinator, and she wished to establish gardens with wheelchair access and for senior citizens to manage it. Renate served many from the Beach Club including the homeless and senior citizens in the local community.

Sara also enjoys volunteering with the Toy Drive and Give Away each year that is held in December for the kids in the Manteo community. This is a huge event but it is well worth it when you see the kids' faces when receiving bikes, helmets, and Christmas bags filled with toys and skate boards. She is an asset to our Board and we are thankful she has agreed to serve another term.

Lynda Hester

Lynda Hester is the chairperson of the Virginia S. Tillett Community Center Advisory Board and excels at leading the monthly meetings while following the agenda in an efficient and timely manner. As such, Lynda automatically serves on other committees; chairing the Planning Committee as well as the Certification Committee that deliberates and prepares paperwork to ensure our Center is recertified. She has worked diligently to achieve the excellence award and state certification. Currently that committee is working on National Certification which will surpass state certification. She is available to other committee meetings at the Center when needed. The Virginia S. Tillett Community Center Advisory Board will continue to function efficiently under her leadership.

Cindy Perry

We find Cindy's background (serving as Community Coordinator on the Board of Outer Banks Tennis Asso. and the committee for Special Abilities Tennis) showcases her organizational skills as well as her ability to work with all age groups in sports and recreational activities. In October of 2021 Cindy received the award as the USTA (United States Tennis Association) of NC local league coordinator of the year

She has attended conferences and classes to facilitate community-based programs and can bring this knowledge to our Board as we strive to expand both educational and recreational programs into our community. She also serves on the Parks and Recreation Advisory Board.

As a Board member, her wealth of established resource partnerships throughout Currituck and Dare Counties will assist us in building on our current programs, events and future endeavors.

VIRGINIA S. TILLET COMMUNITY CENTER ADVISORY BOARD

(Three Year Term)

**This Board advises and promotes goals and policies to enhance
Virginia S. Tillett Community Center operations and community outreach.**

<u>MEMBER</u>	<u>TERM EXPIRATION</u>	<u>ACTION</u>
Rob Ross 105 East Sand Fiddler Court Nags Head, NC 27959 Rob.ross@darenc.com 252-216-6869 (C)	8/23	Apptd. 6/17 Reapptd. 8/20
Teresa Griffin 223 Scuppernong Road. Manteo, NC 27954 tgtjames22@gmail.com 252-475-0173	8/23	Apptd. 7/21
Flossie Tugwell P.O. Box 896 Nags Head, NC 27959 473-5993	8/24	Apptd.8/10 Reapptd. 8/12, 15, 18, 7/21
Mary Pendill 129 Dogwood Circle Manteo, NC 27954 473-3589	8/24	Apptd. 8/14 Reapptd. 8/15, 18. 7/21
Pamela N. Zafra 604 Agona Street Manteo, NC 279545 252-35-6817	8/23	Apptd. 8/20
Lynda Hester, CH. P.O. Box 457 Manteo, NC 27954 ljo48@gmail.com 252-475-1964	8/22	Apptd. 8/10 Reapptd. 8/13, 16, 19
Mitchell Bateman P.O. Box 100 Wanchese, NC 27981 473-3350	8/23	Apptd.8/14 Reapptd. 8/17, 8/20
Samantha Brown 2621 S. Bridge Lane Nags Head, NC 27959 207-2933(H) 305-1414 (O)	8/23	Apptd. 12/16 Reapptd. 8/17 8/20

Sara J. Hester-Smith P.O. Box 762 Manteo, NC 27954 489-6554 sjoihester@gmail.com	8/22	Apptd. 12/17 Reapptd. 8/19
Cindy Perry P.O. Box 2441 Kitty Hawk, NC 27949 252-202-3458 (C)	8/22	Apptd. 1/22
Reha Otte' 185 The Dogwoods Manteo, NC 27954 473-1883(H), 473-8883 (C)	8/22	Apptd. 8/19
Tiffany Wescott P.O. Box 2148 Manteo, NC 27954 216-6341	8/24	Apptd. 8/15 Reapptd. 8/18, 7/21
Marylou Harris 134 Fearing Place Manteo, NC 27954 252-473-2279 (H) 919-880-7465 © mlharris45860@bellsouth.net	8/24	Apptd. 7/21

NOTES:

MEETING INFO: 2nd Tuesday/monthly, at 9 a.m. (except June, July, Aug.)
Virginia S. Tillett Community Center Meeting Room

CONTACT INFO: Lynda Hester, Chairman
Sandy Pace, Director of Virginia S. Tillett Community Center

MEMBERS COMPENSATED: No

Flossie Tugwell filled unexpired term of Betty Blanchard, John Sibunka filled unexpired term of Doris Young and Lynda Hester appointed as an additional member 8/10
John Robbins filled unexpired term of Jimmie Williams 6/12
Suzy Barrett filled unexpired term of Catherine McCabe 2/13; Ann Groves replaced James Harris 9/13
Brooke McCord appointed to fill unexpired term of Malcolm Fearing 9/13
Mitchell Bateman replaced Isabel Cooper 8/14; Mary Pendill filled unexpired term of Betty Mann and Margarette Umphlett replaced Virginia Tillett 12/14
Tiffany Wescott replaced Suzy Barrett and Anastacia Davis replaced Fred Brumbach 8/15.
Jean Council replaced James Brown and Daniel Otte' replaced John Robbins 8/16.
Samantha Brown filled unexpired term of Brook McCord 12/16.
Robb Ross replaced Margarette Umphlett 6/17; Paula Oliver replaced Bea Basnight 8/17
Sarah Hester-Smith appointed to fill unexpired term of Jean Farr Council who resigned 12/17
Lynda Hester, Sara Hester-Smith and Daniel Otte reapptd. 8/19; Reha Otte' apptd 8/5/19 to replace Rodney Benson who resigned; Emily Hall apptd. to fill unexpired term of Paula Oliver 10/19;
Pamela Zafra to fill position of John Sibunka 8/20;
Flossie Tugwell, Mary Pendill, and Tiffany Wescott reappointed for another term, Marylou Harris replaced Anastacia Davis, Teresa Griffin filled unexpired term of Emily Hall 7/21

11/15/21 Dare County Board of Commissioners unanimously adopted a Resolution to rename the Dare County Center the Virginia Tillett Center. 1/18/22 Dare County Board unanimously agreed the name should be the Virginia S. Tillett Community Center. 1/18/22 Cindy Perry appointed to fill the term of David Otte'

REVISED 01/22



Wanchese Community Center

Description

See Attached Summary

Board Action Requested

Take Appropriate Action

Item Presenter

Robert Outten, County Manager

June, 2022

WANCHESE COMMUNITY CENTER BOARD

(Two Year Term)

The Wanchese Community Center Board manages and is responsible
for the upkeep of the community building.

The following terms expire this month:

Joyce T. Meekins

Originally Apptd. 2/2002

Robert L. Walton

Originally Apptd. 07/2005

Robert L. Walton wishes to be reappointed for another term.

Joyce T. Meekins is no longer able to serve.

Applications have been received from Justin Bateman and Elizabeth Creef-Meekins.
They are attached for the Board's consideration to fill the vacancy left by Joyce T. Meekins.

Other Members:
See attached list

WANCHESE COMMUNITY CENTER BOARD
(Two Year Term)

The Wanchese Community Center Board manages and is responsible for upgrading the community building. The community of Wanchese has the opportunity to have reunions, parties, etc. at the community center.

<u>MEMBER</u>	<u>TERM EXPIRATION</u>	<u>ACTION</u>
Joyce T. Meekins Old Schoolhouse Rd. Wanchese, NC 27981 252-473-3087	7-22	Apptd. 2-02 Reapptd. 7-02,04,06, 08,10,12,14,16,18, 20
Tina Sherrod PO Box 484 Wanchese, NC 27981 252-473-1826 (H) 252-216-8223 (B) t.sherrod@aparkinglotmaintenance.com	7-23	Apptd. 4-18 Reapptd. 07/19 6/21
Bill Wilson 291 ER Daniels Rd. Wanchese, NC 27981 252-216-6650	7-23	Apptd. 4-17 Reapptd. 7-17,19 6/21
Sally DeFosse 165 E.R. Daniels Rd. Wanchese, NC 27981 sallyd@darenc.com 252-473-3792	7-23	Apptd. 2-09 Reapptd. 7-09,11,13, 15,17,19, 21
Robert L. Walton P.O. Box 733 Wanchese, NC 27981 252-475-1195	7-22	Apptd. 7-05 Reapptd. 7-06, 08,10, 12,18, 20
Becky Beacham P.O. Box 177 Wanchese, NC 27981 252-473-5313	7-23	Apptd. 7-13 Reapptd. 7-15,17,19 21
Joseph Lee Willis 365 Old Schoolhouse Rd. Wanchese, NC 27981 252-473-5347 (H) 252-475-9505 (B)	7-23	Apptd. 10-18 Reapptd. 07/19 21

NOTES:

MEETING INFO: Quarterly, 1st Tuesday of January, April, July, October, 7:00 p.m., Wanchese Community Center

CONTACT INFO: Becky Beacham, Chairman

MEMBERS COMPENSATED: No

08/93 Rosie Davenport replaced Ruth Whiton
08/94 George Schwartz replaced Harry Horton
07/01 Will Fields replaced Randy O'Neal
02/02 Joyce Meekins filled unexpired term of Linda Byrd Daniels
07/03 Patricia Austin replaced Ken Doughty
10/03 John B. Beasley filled unexpired term of Will Fields
07/05 Jimmie Williams filled unexpired term of George Schwartz
07/05 Robert Walton filled unexpired term of Nora Scarborough
02/09 Sally DeFosse filled unexpired term of Patricia Austin
07/13 Becky Beacham replaced Jimmie Williams
12/14 Robin Holt filled unexpired term of Thomas Baum
04/17 Bill Wilson filled unexpired term of Robin Holt
04/18 Tina Sherrod filled unexpired term of Rosie Davenport (who passed away)
10/18 Joseph Lee Willis filled unexpired term of Lish Meekins (who passed away)
07/19 Tina Sherrod, Bill Wilson, Sally DeFosse, Becky Beacham & Joseph Lee Willis reappointed
07/20 Joyce Meekins and Robert L. Walton reappointed
06/21 Tina Sherrod, Bill Wilson, Sally DeFosse, Becky Beacham & Joseph Lee Willis reappointed

REVISED 6/21



APPLICATION FOR APPOINTMENT

TO DARE COUNTY ADVISORY BOARDS AND COMMITTEES

1st Choice Wanchese Community Center Board

2nd Choice Wanchese Community Center Board

3rd Choice Wanchese Community Center Board

Name Justin Bateman

Address PO Box 87

City/State/Zip Wanchese, NC 27981

Email highway345south@gmail.com

Personal Phone (252)256-3252

Business Phone (252)441-1024

Business Address 2422 S. Wrightsville Ave. Nags Head, NC 27959

Occupation Radio DJ/Sales

Dare County Resident YES
 NO

The text boxes for Education, experience and other should only be 6 lines in order to format nicely on final application form. Text box is limited to 450 characters, but you may have to delete the line breaks.

Educational Background Manteo High School Graduate, Class of 2003. Santa Fe College in Gainesville, Florida - 2 years, 2008-2010.

Business and civic experience and skills Sunday School Teacher, Methodist Men's Chairman, Church Council member and a member of the choir all at Bethany United Methodist Church in Wanchese. I also do a lot of coaching for my son's teams he plays for and my job requires me to be vocal all the time. I don't mind getting my hands dirty either.

Other boards, Committees, Commissions on which you presently serve Current Vice-Chair of the Dare County Parks and Rec. Advisory Board.

REFERENCE #1

Name Bill Hinkle

Business East Carolina Radio Inc.

Address Vista Lake Drive Manteo, NC 27954

Phone (804)229-2739

REFERENCE #2

Name Ken Mann
Business Retired
Address 229 ER Daniels Rd. Wanchese, NC 27981
Phone (252)305-6402

REFERENCE #3

Name Becky Beacham
Business Becky's Barbershop
Address 853 Old Wharf Rd. Wanchese, NC 27981
Phone (252)216-8599

Signature I understand this application will be kept on the active file for three years and I hereby authorize Dare County to verify all information included in this application.

Justin Dateman

Date 1/25/2022



APPLICATION FOR APPOINTMENT

TO DARE COUNTY ADVISORY BOARDS AND COMMITTEES

The Dare County Board of Commissioners believes all citizens should have the opportunity to participate in governmental decisions. One way of participating is by serving as a citizen member on one of the county's advisory boards or committees. If you would like to be considered for appointment to an advisory board or committee, please complete the form below.

Advisory Board or Committee you are interested in:

1st Choice* Wanchese Community Center Board

2nd Choice

3rd Choice

Your Personal Information

Name* Elizabeth Creef-Meekins

Address* PO Box 392

City/State/Zip* Wanchese NC 27981

Email* eseareef@yahoo.com

Personal Phone* Enter 9 digit number. Do not enter any spaces or special characters.
(252)473-3829

Business Phone Enter 9 digit number. Do not enter any spaces or special characters.

Business Address

Occupation* Retired

Residency* Are you a resident of Dare County?

YES

NO

Your Background

*Due to limited space, please complete in paragraph format. The text boxes are limited to 450 characters

Education* ADN from COA graduated in 1985

Experience* Business and civic experience and skills - |
34 years in nursing practice, management in family owned business, Dare county
Jury Commission

Current Services* Other boards/Committees/Commissions on which you presently serve -
Jury Commission

References



List three persons who are not related to you and who have definite knowledge of your qualifications for the position for which you are applying.

REFERENCE #1

Name * Tammy Jennings
Business * Self employed
Address * 155 Steve Basnight Road Manteo NC 27954
Phone * Enter 9 digit number. Do not enter any spaces or special characters.
(252)473-4240

REFERENCE #2

Name * Becky Beacham
Business Self Employed
Address PO Box 177 Wanchese, NC 27981
Phone * Enter 9 digit number. Do not enter any spaces or special characters.
(252)473-5313

REFERENCE #3

Name * Mildred Barkley
Business Retired
Address PO Box 464 Wanchese NC 27981
Phone * Enter 9 digit number. Do not enter any spaces or special characters.
(252)305-3929

Signature * I understand this application will be kept on the active file for three years and I hereby authorize Dare County to verify all information included in this application.

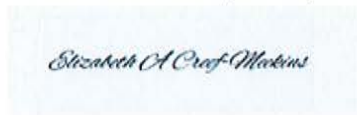

Date 1/19/2022



Library Board - Dare

Description

See Attached Summary

Board Action Requested

Take Appropriate Action

Item Presenter

Robert Outten, County Manager

June, 2022

Library Board - Dare
(Three Year Term)

There are currently two vacancies on the Dare Library Board.

Applications have been received from:
Bea Basnight, Maggie May, Susan Pfaff, Erin Walton and Kevin Wright

**The Library Board recommends the reappointment of
Bea Basnight and Susan Pfaff**

Other Members:
See attached

LIBRARY BOARD – DARE
(Three Year Term)

This Board establishes local policies within those set by the Regional Library Board and oversees the Library Trust Fund Budget; and also serves on the Board of the Dare County Library Foundation, a 503-C3 tax-exempt organization.

<u>MEMBER</u>	<u>TERM EXPIRATION</u>	<u>ACTION</u>
Marylou Hoffert 179 Clam Shell Trail Southern Shores, NC 27949 757-214-5689 (C) mlh6126@gmail.com	10/24	Apptd. 10/21
Ruth Perkins 4807 Palmer Drive Kitty Hawk, NC 27949 980-241-4628 (H), 252-473-4290 (W) ruthbigailperkins@gmail.com	10/24	Apptd. 10/21
Joann Wilson-Harfst 1723 Virginia Avenue Kill Devil Hills, NC 27948 804-384-1584 joannharfst@gmail.com	10/24	Apptd. 10/21
Mike Hogan, Chairman P.O. Box 1898 Kill Devil Hills, NC 27948 441-6493 (H), 256-0036 (O)	06/23	Apptd. 6/14 Reapptd. 6/17,10/21
Vacant		
Ervin Bateman (Comm. Apptee) 4148 Poor Ridge Road P.O. Box 1127 Kitty Hawk, NC 27949 ervin.bateman@darenc.com 216-1526 (C)	06/23	Apptd. 1/19 Four year terms
Janice Willis P.O. Box 413 Hatteras, NC 27943 986-2109 (H), 986-2365 (O)	06/23	Apptd. 6/14 Reapptd. 6/17, 10/21

Vacant

NOTES:

MEETING INFO: 2nd Thursday, 10:00 a.m. in Jan, April, July & Oct. in any library

CONTACT INFO: Mike Hogan, Chairperson; Jonathan Wark, Librarian

MEMBERS COMPENSATED: No

At the June 6, 2016 meeting, the DCBOC voted to delete the rule that limited people to serving only two consecutive, two-year terms.

Jack Hohmann was first appointed to the Board April 1977.
Robert Morrill replaced Harrison Baggerly & Stella Green replaced Margot Tillett 6/90.
Helen Kleyla replaced Bea Mulford 6/92; Nora Fucci replaced Cashar Evans 6/93.
Wayne Gray appointed to fill term of Jack Hohmann 11/93.
Martha Hohmann replaced Hilda Bayliss 6/94; Pat Eure replaced Helen Kleyla 7/95.
Jan DeBlieu replaced Nora Fucci & Elizabeth Newman replaced Robert Morrill 6/96.
James Melvin replaced Stella Green 6/96.
Beth Storie replaced Martha Hohmann, Cheryl Byrd replaced Polly Bernd and
Jan Willis replaced Ray Gray 6/97. Cheryl Byrd replaced Wayne Gray who resigned 8/98.
John "Possum" Silver appointed to fill position vacated by Cheryl Byrd 8/98.
Roger Allen replaced James Melvin 6/99; Debbie Sauls replaced John Silver 6/00.
John Robert Hooper replaced Cheryl Byrd 3/01.
Dorothy Fink replaced Pat Eure and Paul Charron filled term of Beth Storie 8/01.
Laura Perkins replaced Jan DeBlieu and Mel Covey replaced Elizabeth Newman 8/02.
Lynne Hutchins replaced Roger Allen 11/02; Betty Swanson replaced Jan Willis 6/03.
Amy Huggins filled unexpired term of Paul Charron 10/04.
Janis Cochrane apptd. to fill Mel Covey term & Mike Johnson apptd. to fill John R. Hooper 1/05.
Lynne Foster filled term of Dorothy Fink and Michael Hogan filled term of Debbie Sauls 10/05.
Commissioner Virginia Tillett replaced Commissioner Mike Johnson 2/08.
Fletcher Willey replaced Laura Catoe & Karen Bachman replaced Janis Cochrane and
Joyce Bornfriend replaced Lynne Hutchins 7/08.
Donna Trivette replaced Betty Swanson, William Pfeifer replaced Amy Huggins and
Elizabeth Gaimel replaced Michael Hogan 12/09; Jerry Hart replaced Lynne Foster 6/10.
Ellen Bryson filled term of Fletcher Willey & Lisa Phillips filled term of Jerry Hart 8/11.
Margaret Umphlett replaced Virginia Tillett 12/14.
Sandra Carter replaced Donna Trivette & Willard Haithcock replaced Elizabeth Gaimel 6/15.
Beverly Boswell filled unexpired term of William Pfeifer 6/16.
Beverly Boswell resigned 4/17; Rob Ross replaced Margaret Umphlett 6/17
Sandra Carter has moved out of Dare County 6/18; Ervin Bateman replaced Rob Ross 1/19
Mike Hogan & Janice Willis reappointed 10/21, MaryLou Hoffert & Ruth Perkins appointed 10/21
Lisa Phillips moved out of the area and removed from membership 05/22

REVISED 05/22

APPLICATION FOR APPOINTMENT TO
DARE COUNTY ADVISORY BOARDS AND COMMITTEES

The Dare County Board of Commissioners believes all citizens should have the opportunity to participate in governmental decisions. One way of participating is by serving as a citizen member on one of the county's advisory boards or committees. If you would like to be considered for appointment to an advisory board or committee, please complete the form below and mail to Cheryl Anby, P.O. Box 1000, Manteo, N.C. 27954 or fax it to her at 473-1817, or send it by email to cheryl.anby@darenc.com

Advisory Board or Committee interested in:

1st choice ABC Board

2nd choice Dare Library

3rd choice _____

Name Bea Basnight

Address 177 Scuppernon Road

City/State/Zip Manteo, NC 27954

Email Address beabasnight@AOL.com

Telephone Home: 252-473-3856 / cell - 252-475-0105

Business: _____

Resident of Dare County: yes no

Occupation: Retired Teacher

Business Address: _____

Educational background:

Bachelor of Arts in Elementary Education - Elon University

Masters Degree in Education - East Carolina University

Business and civic experience and skills:

- ① Teacher - Dare County Schools; ② Vice-chair and Chairman - Dare County Board of Education; ③ Secretary, Vice-Chair, Chairman of the Roanoke Island Historical Association; ④ Vice-chair of the Dare County Center Advisory Board; ⑤ Founding member and Co-chair of the Hands of Hope Advisory Board; ⑥ North Carolina Advisory Committee on Grading in Schools; ⑦ School Representative on the Dare Education Foundation

Other Boards/Committees/Commissions on which you presently serve:

- ① Dare County Arts Council Board - co-chair of Fundraising
- ② College of the Albemarle New Building Advisory/Ambassador Committee
- ③ 1587 Society of the Roanoke Island Historical Association

REFERENCES

List three persons who are not related to you and who have definite knowledge of your qualifications for the position for which you are applying.

Name	Business/Occupation	Address	Telephone
① <u>Malcolm Fearing</u>	<u>Developer/Business Owner</u>	<u>P.O. Box 759, Manteo, NC 27954</u>	<u>305-8596</u>
② <u>Margaret Lawler</u>	<u>Dare County Board of Education Vice Chair</u>	<u>81 Gravey Pond Lane, Southern Shores, NC 27949</u>	<u>261-5482</u>
③ <u>Mary Ellen Ballance</u>	<u>Dare County Board of Education Chair</u>	<u>P.O. Box 756, Hatteras, NC 27943</u>	<u>305-2685</u>

I understand this application will be kept on the active file for three years and I hereby authorize Dare County to verify all information included in this application.

Date: 6-14-21 Signature of applicant: Bea Basnight

FOR OFFICE USE ONLY:

Date received: 6/16/21

2/28/22 - Bea Basnight called and asked to add Dare Library to her application - (CCA)

APPLICATION FOR APPOINTMENT TO
DARE COUNTY ADVISORY BOARDS AND COMMITTEES

The Dare County Board of Commissioners believes all citizens should have the opportunity to participate in governmental decisions. One way of participating is by serving as a citizen member on one of the county's advisory boards or committees. If you would like to be considered for appointment to an advisory board or committee, please complete the form below and mail to Cheryl Anby, P.O. Box 1000, Manteo, N.C. 27954 or fax it to her at 473-1817, or send it by email to cheryl.anby@darenc.com

Advisory Board or Committee interested in:

1st choice Albemarle Region Resource & Development

2nd choice Library

3rd choice Transportation

Name Maggie May

Address 109 E Sir Walter Raleigh Dr, KDH

City/State/Zip _____

Email Address cmmay2@ncsu.edu

Telephone Home: ~~(828)~~ 773-6704 (252) 489-9945

Business: _____

Resident of Dare County: yes no

Occupation: Professor

Business Address: _____

Educational background:

NC state university, EdD

Appstate, Masters

Business and civic experience and skills:

Attached

Other Boards/Committees/Commissions on which you presently serve:

Attached

REFERENCES

List three persons who are not related to you and who have definite knowledge of your qualifications for the position for which you are applying.

Name	Business/Occupation	Address	Telephone
<u>Attached</u>			

I understand this application will be kept on the active file for three years and I hereby authorize Dare County to verify all information included in this application.

Date: 8/11/2020

Signature of applicant: 

FOR OFFICE USE ONLY:

Date received: 8/2020



APPLICATION FOR APPOINTMENT TO
DARE COUNTY ADVISORY BOARDS AND COMMITTEES

Advisory Board or Committee interested in:

1st choice: Library Board - Dare

2nd choice:

3rd choice:

Name: SUSAN PFAFF

Address: 237 W. LOOKOUT ROAD

City/State/Zip: NAGS HEAD, NC 27959

Email Address: sspfaff5@gmail.com

Telephone: Home: (216)780-4478 Business:

Resident of Dare County: YES

Occupation: RETIRED

Business Address:

Educational background:

I attended Cuyahoga Community College in Cleveland, Ohio, Xavier University in Cincinnati, Ohio and Ohio Wesleyan University in Delaware, Ohio.

Business and civic experience and skills:

I taught pre-k for 28 years and was project manager for multiple non-profit family literacy and early childhood education programs in Shaker Heights, Ohio. Soon after I retired to Nags Head, I tutored for Mano al Hermano, a volunteer based family literacy program for Latino children in Dare County Schools, eventually becoming an administrator for the program through Children & Youth Partnership. I also created and manage 5 websites here in OBX.

Other Boards/Committees/Commissions on which you presently serve:

I serve on the Board of Directors of League of Women Voters of Dare County.

REFERENCES

List three persons who are not related to you and who have definite knowledge of your qualifications for the position for which you are applying.

Name	ROSEMARY RAWLINS
Business/Occupation	WRITER
Address	2507 S. BRIDGE LANE, NAGS HEAD 27959
Telephone	(804)651-3554



APPLICATION FOR APPOINTMENT TO
DARE COUNTY ADVISORY BOARDS AND COMMITTEES

Name BARBARA HARDY
Business/Occupation RETIRED TEACHER
Address 7 FERN LN, KITTY HAWK, NC 27949
Telephone (252)202-1580

Name MAUREEN KING
Business/Occupation RETIRED TEACHER
Address 7033 CURRITUCK RD, KITTY HAWK, NC 27949
Telephone (252)256-1296

I understand this application will be kept on the active file for three years and I hereby authorize Dare County to verify all information included in this application.

Signature of applicant:

Susan Pfaff

Date: 5/19/2022

APPLICATION FOR APPOINTMENT TO
DARE COUNTY ADVISORY BOARDS AND COMMITTEES

The Dare County Board of Commissioners believes all citizens should have the opportunity to participate in governmental decisions. One way of participating is by serving as a citizen member on one of the county's advisory boards or committees. If you would like to be considered for appointment to an advisory board or committee, please complete the form below and mail to Cheryl Anby, P.O. Box 1000, Manteo, N.C. 27954 or fax it to her at 473-1817, or send it by email to cheryl.anby@darenc.com

Advisory Board or Committee interested in:

1st choice Library Advisory Board

2nd choice _____

3rd choice _____

Name Erin Walton

Address 52632 Piney Ridge Road

City/State/Zip Frisco, NC 27936

Email Address erin.p.walton@gmail.com

Telephone Home: 252-230-1780

Business: N/A

Resident of Dare County: yes no Permanent Resident of Hatteras Island
DL reflects previous Garner, NC address

Occupation: Former Director of Library Services for the Kenly Public Library (The Town of Kenly)

Business Address: N/A

Educational background:

MS in Management, Wake Forest University School of Business

BA in English Literature & Anthropology, Wake Forest University

Business and civic experience and skills:

MS in Management ; Five years professional experience:

Aon Hewitt, Verizon Enterprise Solutions, Town of Kenly

↓
Business Delivery Specialist

↓
Project Manager

↓
Library Director

Other Boards/Committees/Commissions on which you presently serve:

N/A

REFERENCES

List three persons who are not related to you and who have definite knowledge of your qualifications for the position for which you are applying.

Name	Business/Occupation	Address	Telephone
<u>Peggy Jo Batten</u>	<u>Chairman, Kentry Library Board</u> <u>Professor of Mathematics</u>	<u>Kentry, NC</u>	<u>919-965-1172</u>
<u>Libby Moringo</u>	<u>Library Assistant, Kentry Library</u>	<u>Kentry, NC</u>	<u>919-868-4351</u>
<u>Ronita Barksdale</u>	<u>Director, Laurens County</u> <u>Public Library System</u>	<u>Laurens, SC</u>	<u>864-681-7323</u>

I understand this application will be kept on the active file for three years and I hereby authorize Dare County to verify all information included in this application.

Date: 4/30/2021 Signature of applicant: Erin Pope Watter

FOR OFFICE USE ONLY:

Date received: 4/30/21

APPLICATION FOR APPOINTMENT TO
DARE COUNTY ADVISORY BOARDS AND COMMITTEES

The Dare County Board of Commissioners believes all citizens should have the opportunity to participate in governmental decisions. One way of participating is by serving as a citizen member on one of the county's advisory boards or committees. If you would like to be considered for appointment to an advisory board or committee, please complete the form below and mail to Cheryl Anby, P.O. Box 1000, Manteo, N.C. 27954 or fax it to her at 473-1817, or send it by email to cheryl.anby@darenc.com

Advisory Board or Committee interested in:

1st choice: Library Board -- Dare

2nd choice: N/A

3rd choice: N/A

Name: Kevin V. Wright

Address: 112 Quail Way

City/State/Zip: Duck, NC 27949-4604

Email Address: kvwkmw@gmail.com

Telephone: Home: (252) 715-4286 Mobile: (301) 980-5629

Business: N/A

Resident of Dare County: Yes

Occupation: Retired

Business Address: N/A

Educational background:

BA (Modern Languages), Virginia Military Institute, Lexington VA, 1975

Fulbright-Hays Fellowship, Ludwig-Maximilians-Universität München (Munich, Germany) 1975-6

MA (German), Vanderbilt University, Nashville TN, 1979

Graduate Exchange Fellowship, Freie-Universität Berlin (Berlin, Germany), 1979-1980

United States Army Senior Service College Fellowship, 1999-2000

Business and civic experience and skills:

25 years (1980-2005) of increasingly complex leadership and management experience in command and staff positions as a commissioned military intelligence officer in the United States Army. Retired in the grade of Colonel (O-6).

3 years (2005-2008) as defense contractor with CACI, Inc. and Lockheed-Martin, providing intelligence planning, systems architecture, and strategy support to Department of Defense geographic combatant commands located in Germany. Served on multiple military-related boards.

8 years (2009-2017) as Department of Defense civil servant (in the grade of GG-14) with the Defense Intelligence Agency, conducting operational and strategic intelligence planning and strategy formulation. Served on multiple defense intelligence-related boards and committees. Retired in 2017.

2 years' experience (2020-2021) as voting member of Southern Shores Library Committee. Appointed by Town of Duck as one of two representatives to the committee, which was established by the Town of Southern Shores.

1 year experience (2021) as voting director and elected treasurer of the Duck Community and Business Alliance, a civic organization.

Other Boards/Committees/Commissions on which you presently serve:

Southern Shores Library Committee (Town of Duck Representative)

Duck Community and Business Alliance (Treasurer)

REFERENCES

List three persons who are not related to you and who have definite knowledge of your qualifications for the position for which you are applying.

Name	Business/Occupation	Address	Telephone
Lilias Morrison	NC Licensed Builder/Broker	43 Fairway Drive Southern Shores NC 27949	(252) 202-7743
Avery Harrison	Bookseller (Downtown Books)	128 Sea Hawk Drive W Duck NC 27949	(252) 202-1778
Terri Cullen	Docent, Whalehead Club	122 Martin Lane Duck NC 27949	(252) 261-8759

I understand this application will be kept on the active file for three years and I hereby authorize Dare County to verify all information included in this application.

Date: 16 June 2021 Signature of applicant:



FOR OFFICE USE ONLY:

Date received:

6/16/21



Fessenden Center Advisory Board

Description

See Attached Summary

Board Action Requested

Take Appropriate Action

Item Presenter

Robert Outten, County Manager

June, 2022

FESSENDEN CENTER ADVISORY BOARD

This Advisory Board establishes goals and policies to enhance the Fessenden Center operation and community outreach consistent with the goals, objectives and policies of Dare County. The overall objective is to develop procedures and operations that improve the quality of life through interaction of all age groups on Hatteras Island.

The Board has two vacancies and recommends Wendi Munden for appointment for the Buxton vacancy.

Other Members:
See attached list

FESSENDEN CENTER ADVISORY BOARD

(Four Year Term)

This Advisory Board establishes goals and policies to enhance the Fessenden Center operation and community outreach consistent with the goals, objectives, and policies of Dare County. The overall objective is to develop procedures and operations that improve the quality of life through interaction of all age groups on Hatteras Island.

<u>MEMBER</u>	<u>TERM EXPIRATION</u>	<u>ACTION</u>
Kenneth Brite P.O. Box 95 Avon, NC 27915 252-996-0432 kbrite@darenc.com (Rodanthe area)	6-24	Apptd. 2/17; Reapptd. 6/20
Vacant (Buxton area)		
Keith Durham P.O. Box 713 Buxton, NC 27920 910-514-4538 durhamke@daretolearn.org (Salvo area)	6-24	Apptd. 2/17; Reapptd. 6/20
Marcie Shoemaker P.O. Box 161 Buxton, NC 27920 252-995-5799 (H) 252-996-0581 (O) budnmar@earthlink.net (Buxton area)	6-26	Apptd. 2/16 Reapptd. 6/1; 5/22
Robyn (Hali) Easley P.O. Box 613 Hatteras, NC 27943 Cell 252-996-0043 Business 252-986-2154 Rustygirl2007@aol.com (Hatteras area)	6-24	Apptd. 6/18 Reapptd. 6/16; 6/20
Forrest Paddock P.O. Box 534 Buxton, NC 27920 252-216-7856 fgpaddock@outlook.com (Frisco area)	6-26	Apptd. 2/17 Reapptd. 6/18; 5/22
Edward J. O'Brien, Jr. 41193 Carronade Ct., P.O. Box 805 Avon, NC 27915 Edobrien41193@gmail.com 610-842-9065 (Avon area)	10-25	Apptd. 10/21

Vacant
At-Large

Megan Vayette 47520 Lost Tree Tr., Box 1257 Buxton, NC 27920 252-216-7176 mvayette@gmail.com (At Large)	10/25	Apptd., 10/21
James Richard Kenner P.O. Box 1044 47106 Middle Ridge Trail Buxton, NC 27920 252-216-5427 richk@chec.coop (At Large)	6-26	Apptd. 6/19 Reapptd: 5/22
John Griffin P.O. Box 382 Rodanthe, NC 27968 252-987-2332 griffijt@embarqmail.com (At Large)	6-24	Apptd. 7/10 Reapptd. 7/12,16 6/20
Danny Couch 47297 Dippin Vat Road P.O. Box 1001 Buxton, NC 27920 dannyc@darenc.com 252-216-7383 (Commissioner Appointee)	6-26	Apptd. 6/17 Reapptd. 6/18; 5/22

MEETING DATE: Quarterly, Fessenden Center

NOTE: Chairman Bobby Owens appointed to serve at the pleasure of the Board as long as he is serving as a county commissioner.

3/97 Apptd. USCG Representative to seat on the Board. Though apptd. 3/97, term will expire 6/98 to keep consistent with other appointments

- 10/97 - Commissioner Mac Midgett replaced Bobby Owens.
- 3/99 - George Volsky apptd. to fill term of Bill Barley, Kathy Kiddy apptd. to fill term of Tom Barclay.
- 5/99 - Jinny McBride apptd. to fill unexpired term of Jackie Leeling.
- 9/00 - Rev. Holt Clarke fill unexpired term of Rev. Jim Huskins and Commissioner John Robert Hooper appointed to replace Mac Midgett.
- 5/02 - Michelle Edwards appointed to fill unexpired term of Jenny Hooper.
- 6/04 - Heidi Blackwood to fill term of George Volsky and Charles Moseley to fill term of Holt Clarke
- 6/04 - Matt Caviness apptd. to fill expired term of Dave Umberger.
- 6/04 - Susan Gray to fill term of Michelle Edwards & Jennifer Kingery apptd. to fill term of Jane Oden.
- 1/05 - Commissioner Mac Midgett replaced John Robert Hooper.
- 3/06 - Allen Burrus replaced the late Mac Midgett.
- 6/06 - Jack Painter replaced John Leatherwood.
- 11/08 - Steve Jennette filled unexpired term of Ken Wenberg.
- 2/09 - Rev. Cory B. Oliver filled unexpired term of Rev. Charles Moseley.
- 6/09 - Cheryl Austin filled term of Kathy Kiddy and Danny Couch filled term of Jennifer Kingery.

- 7/10 - John Griffin filled unexpired term of Ormond Fuller.
- 7/12 - Mary Ellen D. Balance replaced Danny Couch.
- 3/14 - Laura Fiscus filled term of Cheryl Austin and Sonny Quidley filled term of Susan Gray.
- 2/16 - Marcie Shoemaker filled unexpired term of Heidi Blackwood.
- 2/17 - Kenneth Brite filled term of Laura Fiscus & Keith Durham filled term of Sonny Quidley.
- 2/17 - Forrest Paddock filled unexpired term of Jack Painter.
- 6/17 - Danny Couch appointed to replace Allen Burrus
- 2/18 - Louise Rossiter passed away
- 6/18 - Robyn (Hali) Easley filled unexpired term of Mary Ellen Balance
- 6/19 - James Kenner filled At-Large vacancy caused by death of Louise Rossiter
- 2/22 - Steven Jennette passed away and William Lengyel resigned
- 5/22-- Forrest Paddock, Marcie Shoemaker, James Kenner, & Danny Couch were all reappointed.

REV. 05/22



APPLICATION FOR APPOINTMENT

TO DARE COUNTY ADVISORY BOARDS AND COMMITTEES

1st Choice	Fessenden Center Advisory Board	▼
2nd Choice		▼
3rd Choice		▼
Name	Wendi Munden	
Address	46080 Diamond Shoals Dr	
City/State/Zip	Buxton NC 27920	
Email	wendipalm@gmail.com	
Personal Phone	(252)305-0090	
Business Phone		
Business Address		
Occupation	Pool and spa operator	
Dare County Resident	<input checked="" type="radio"/> YES <input type="radio"/> NO	

The text boxes for Education, experience and other should only be 6 lines in order to format nicely on final application form. Text box is limited to 450 characters, but you may have to delete the line breaks.

Educational Background	Cape Hatteras high school graduate, studied at college of the albemarle graduating with associates degree in art
-------------------------------	--

Business and civic experience and skills

Current board member with the Hatteras island cancer foundation. Taught yoga for the Hatteras civic association. Owned and operated Hatteras Island weddings and events a wedding planning business on Hatteras island for 3 years

Other boards, Committees, Commissions on which you presently serve

Board member with Hatteras island cancer foundation

REFERENCE #1

Name Sydney Slaughter
Business Sunflower florist
Address Hwy12 Buxton NC 27920
Phone (252)473-0830

REFERENCE #2

Name Chris Romanko
Business Point Break pool and spa
Address
Phone (252)305-1503

REFERENCE #3

Name Kevin Scalia
Business Hatteras Island Boardsports

Address

Phone

Signature

I understand this application will be kept on the active file for three years and I hereby authorize Dare County to verify all information included in this application.

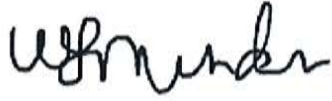

Date

Comments

Reviewed



Game and Wildlife Commission

Description

See Attached Summary

Board Action Requested

Take Appropriate Action

Item Presenter

Robert Outten, County Manager

June, 2022

GAME AND WILDLIFE COMMISSION
(Three Year Term)

The Game and Wildlife Commission issues and renews duck blind licenses in all Dare County waters. Renewals and new licenses are received on a yearly basis from August through December of each year.

The following have terms to expire July 2022:

Timmy Midgett
Mike Johnson
Edward "Bow" Meekins

They would all like to be reappointed for another three-year term

There are no applications on file.

Other Members: See attached list

DARE COUNTY GAME AND WILDLIFE COMMISSION

(Staggered/Three Year Terms)

Issues and renews blind licenses in all Dare County waters. Renewals and new licenses are received on a yearly basis from August through December of each year.

<u>MEMBER</u>	<u>TERM EXPIRATION</u>	<u>ACTION</u>
Kyle Perry 50304 Snug Harbor Drive Frisco, NC 27936 996-0186 (H) 995-5366 (W) kyle@friscorodandgun.com	7-23	Apptd. 7/17 Reapptd. 6/20
Missy McPherson 119 Margaret Court Manteo, NC 27954 473-6831 (H) 216-6831 (C) 473-1292 (W) missyseca@hotmail.com	7-23	Apptd. 7/17 Reapptd. 6/20
Timmy Midgett P.O. Box 250 Manns Harbor, NC 27953	7-22	Apptd. 8/16 Reapptd. 7/19
Mike Johnson P.O. Box 9 Wanchese, NC 27981 441-6958 (H) 473-8262 (W)	7-22	Apptd. 11/05 Reapptd. 7/07,10,13,16, 07/19
Edward "Bow" Meekins P.O. Box 532 Wanchese, NC 27981 423-1403 (H) 473-1803 (W)	7/22	Apptd. 7/13 Reapptd. 7/16,19
Robert Owens 711 Carolina Court Manteo, NC 27954 202-3425 (W) homedevlopment@yahoo.com	7-23	Apptd. 7/17 Reapptd. 6/20
George Henderson PO Box 606 Manteo, NC 27954 256-0596 (C) lforester924@gmail.com	7-23	Apptd. 8/77 Reapptd. 8/90, 7/92, 7/94, 8/97, 8/00, 7/02,05,08 11,14,17,20
Dr. Andrew F. Horne 6405 N. Croatan Hwy. Kitty Hawk, NC 27949 261-2250 (W) 261-2725 (H)	7-24	Apptd. 10/97 Reapptd. 8/00, 7/03,06,09,12,15 7/18, 6/21
Phil Haywood 2473 Colington Rd. Kill Devil Hills, NC 27948 441-5705	7-24	Apptd. 8/90 Reapptd. 7/92, 7/94, 8/97, 8/00, 7/03,06,09,12,15,18 21

Harvey Scarborough, Jr. 7-24 Apptd. 7/11
P.O. Box 571 Reapptd.; 7/12,15,18, 21
Avon, NC 27915
252-996-0050 (C)

Buddy Shelton 7-24 Apptd. 7/18
291 Bayview Drive Reapptd. 6/21
Stumpy Point, NC 27978
473-5572
buddy.shelton59@gmail.com

NOTES:

MEETING INFO: Once a month, August – December, 7 p.m., Rm. 168, Dare County Adm. Building

CONTACT INFO: Dr. Andrew F. Horne, Chairman
Melva Garrison, Game and Wildlife Clerk

MEMBERS COMPENSATED: \$25 per meeting
\$50 per meeting – Chairman

Bill Walker replaced Randy O'Neal 8/86; Phil Haywood replaced Robert D. Parker 1986.
Sonny Briggs replaced Ken Mann 8/90; David Pruitt replaced Gary Dowdy 8/93.
Leland Midgett replaced Allen Burrus & Barry Martin replaced John Booth, Jr. 7/94.
Bryan Perry replaced Leland Midgett 8/94.
Gen. Statute required term to be for 3 years. Changed terms at direction of County Attorney. (6/24/96)
William H. Wilson replaced Barry Martin and Allan Newcomb replaced Ray Scarborough 8/97.
Dr. Andrew F. Horne replaced Allan Newcomb 10/97.

Timmy Midgett appointed to fill unexpired term of Harry Mann 12/98.

To create staggered terms enacted by the Gen. Assembly, Atty Al Cole recommended: Reappt. Timmy Midgett, David Pruitt, Bill Walker for 1 yr.; Reappt. Bryan Perry, Earl Ray Mann, Sonny Briggs, George Henderson for 2 yrs; Reappt. Andrew Horne, Phil Haywood, William Wilson, Manson Meekins for 3 yrs. This action was done at the 8/7/00 DCBOC meeting.

Mike Johnson apptd. to fill unexpired term of David Pruitt 11/05; Buddy Shelton replaced Earl Mann 7/08.
Harvey Scarborough, Jr. appointed to fill unexpired term of William Wilson, 7/11.

Phil Sawyer appointed to fill unexpired term of Manson Meekins 9/11.

Edward "Bow" Meekins replaced Bill Walker 7/13; Eddie Twyne replaced Timmy Midgett 7/16.

Timmy Midgett apptd. to fill unexpired term of Eddie Twyne 8/16.

Mr. Twyne unable to serve due to work schedule conflict.

Kyle Perry replaced Bryan Perry and Missy McPherson replaced Buddy Shelton 7/17

Robert Owens replaced Sonny Briggs 7/17

Buddy Shelton replaced Phil Sawyer who resigned & did not want to be reappointed 7/18

Timmy Midgett, Mike Johnson and Edward Meekins reappointed 7/19

Kyle Perry, Missy McPherson, Robert Owens and George Henderson reappointed 6/20

Andrew Horne, Phil Haywood, Harvy Scarborough, Jr. and Buddy Shelton reappointed 6/21

REVISED 6/22



Commissioners' Business & Manager's/Attorney's Business

Description

Remarks and items to be presented by Commissioners and the County Manager.

Board Action Requested

Consider items presented

Item Presenter

Robert Outten, County Manager